



**Environmental Impact
Assessment Guidelines for
Mine Development and
Tailings Disposal at
Tropical Coastal Mines**



South Pacific Regional Environment Programme

**Environmental Impact
Assessment Guidelines for
Mine Development and
Tailings Disposal at
Tropical Coastal Mines**

Prepared by Derek Ellis
Assisted by Jacqueline Connolly

SPREP Library Cataloguing-in-Publication Data

Ellis, Derek

Environmental impact assessment guidelines for mine development
and tailings disposal at tropical coastal mines / prepared by
Derek Ellis and assisted by Jacqueline Connolly. - Apia, Western Samoa : SPREP, 1996.

viii, 26p. : figs., plates, tables ; 29 cm.

ISBN: 982-04-0150-X

1. Environmental impact statements. 2. Mines and mineral
resources - Environmental aspects. 3. Environmental monitoring.
I. Connolly, Jacqueline. II. South Pacific Regional Environment
Programme. IV. Title.

333.765

Prepared for publication by the
South Pacific Regional Environment Programme,
PO Box 240, Apia, Western Samoa

© South Pacific Regional Environment Programme, 1996

The South Pacific Regional Environment Programme authorises
the reproduction of textual material, whole or part, in any form,
provided appropriate acknowledgement is given.

Original text: English

Editor
Barbara Henson

Production
Peter Evans

Photographs
Plate 1 (cover and p.4) reproduced with permission of
Island Copper Mine, BHP Minerals Canada Ltd;
plate 6 (cover and p.6) and plate 5 reproduced
with permission of Placer Pacific Limited.

Typeset in 11/13 Bembo and URW Castle
Printed on 110gsm Tudor R.P. (100% recycled) by
ABC Printing, Brisbane, Australia
Printed with financial assistance from AusAID

Cover photographs

Top: *The scale of waste production from mining
and milling processes can be enormous. Here, we see
the waste rock dumps and their reclamation at
Island Copper Mine, Canada. The tailings are
underwater.*

Bottom: *A seawater-mix de-aeration tank for
submarine tailings discharge.*

Contents

Acknowledgements	v
List of participants, mining workshop, Solomon Islands, March 1992	vi
Executive summary	vii
Part One Mine development and tailings disposal	1
1 Introduction	3
1.1 Overview	3
1.2 Production of tailings: the mining-milling process	3
1.3 Environmental risks	7
1.4 Regulation and these Guidelines	8
2 Description of procedures	10
2.1 Overview	10
2.2 Exploration	10
2.3 Development: Feasibility assessment	11
2.4 Development: Blueprinting	12
2.5 Development: Construction and commissioning	13
2.6 Operations	13
2.7 Closure	14
3 Numerical guidelines	16
References	20
Part Two Environmental questionnaires	21
Preliminary information to be compiled by the Regulatory Agency for a mine development	22
Preliminary information to be compiled by an applicant for a mining licence	23
Tables	
3.1 Guideline values for trace metals (ppm, dry wt) and per cent incidence of biological effects in concentration ranges defined by the values, ERL and ERM	16
3.2 Draft Canadian Guidelines, and incidence of adverse biological effects in concentration ranges defined by values for marine sediments, TEL and PEL	18
3.3 Draft Canadian Guidelines and incidence of adverse biological effects in concentration ranges defined for fresh water sediments	18
3.4 Sediment criteria for six elemental contaminants derived from water quality criteria and equilibrium partitioning coefficients	18
3.5 Guidelines for marine sediments comparing values from Tables 3.1, 3.2 and 3.4	19

Figures

- 1.1 Waste produced from mining 4
- 3.1 The potential for biological effects of sediment-sorbed contaminants tested in the US National Status and Trends Program 17

Plates

- 1 Island Copper Mine, Rupert Inlet, British Columbia, Canada 4
- 2 Mine pit in an interior valley 5
- 3 Impact of tailings discharge on a river valley 5
- 4 Tailings discharge at the sea edge 6
- 5 A mine pit engineered for reclamation 6
- 6 Seawater-mix de-aeration tank for submarine tailings discharge 6

Acknowledgements

The development of these Guidelines was funded initially by the Canadian International Development Agency (CIDA) through the medium of a grant for a Training Programme in Marine Pollution Assessment and Control to the University of Victoria, Canada and the University of the South Pacific, Suva, Fiji.

This grant allowed presentation of a workshop on the marine impact of coastal and island mines at Honiara, Solomon Islands, 2-6 March 1992. The workshop was facilitated by cooperation with the Government of the Solomon Islands and the South Pacific Regional Environment Programme (SPREP).

Subsequently, SPREP was able to fund the updating and formalising of these Guidelines by J. Connolly. This was carried out under the supervision of D. Ellis, made available by the University of Victoria. The authors are pleased to acknowledge this agency support in allowing development of these Guidelines.

The authors are also very grateful for the cooperation of particular individuals. We acknowledge first Mr Komeri Onorio, Environmental Impact Assessment Officer of the South Pacific Regional Environment Programme (SPREP), who coordinated arrangements for the Honiara workshop and facilitated arrangements for completion of the Guidelines. We also thank the participants of the workshop, and the Solomon Islands public servants who assisted in the organisation.

Several of D. Ellis's associates and correspondents have contributed over the years much background information which has been incorporated into these Guidelines. These associates include a series of environmental managers at coastal mines, particularly C. Pelletier, R. Hillis and I. Horne at Island Copper Mine, Canada and G. Murray of Placer Pacific Ltd. E. Long of the US National Oceanographic and Atmospheric Administration (NOAA) has provided and updated information about numerical guidelines under development in the United States. Professor G. W. Poling of the University of British Columbia, Vancouver, Canada has been a frequent source of mine-milling information over the past twenty-five years.

List of Participants, Mining Workshop, Solomon Islands, March 1992

Narua Lovai, Department of Environment and Conservation, Papua New Guinea

Venasio Nasara, Department of Mineral Resources, Fiji

Kolinio Bula, Department of Mineral Resources, Fiji

Charles Vatu, Environmental Unit, Ministry of Natural Resources, Vanuatu

Simon Koke, Ministry of Agriculture and Lands, Solomon Islands (SI)

Bernard Telei, Environment and Conservation Division, SI

Rosemary Kinne, College of Higher Education, SI

John Warden, College of Higher Education, SI

Alex Makini, College of Higher Education, SI

Robinson Fugui, Chief, Environmental Health Division, SI

John Korinihana, Environmental Health Division, SI

Ped Shanel, Gold Ridge Landowners Representative, SI

Nicholas Biliki, Geology Division, Ministry of Natural Resources, SI

Don H. Tolia, Geology Division, Ministry of Natural Resources, SI

Moses Biliki, Ministry of Education and Human Resources, SI

Henry Isa, Environment and Conservation Division, SI

Instructors

Dr. D. V. Ellis, University of Victoria, Canada

Dr. P. Hughes, Kinhill Engineering, Darwin, Australia

Executive Summary

Disposal of tailings constitutes one of the most significant areas of potential environmental risk associated with coastal and island mine development. These Guidelines provide narrative and numerical targets for environmental protection during the development and operation of coastal and island mines that may discharge tailings to the sea.

The Guidelines are targets in the sense that mine developers and operators should aim at their achievement. They are not standards and may not be attainable under all circumstances.

It is recognised that site-specific, environmental, mining and other technical or socio-economic factors may require adjustments at particular sites, and that these may be either more or less constraining on operations. These adjustments must be supported by detailed information.

Mine tailings can be disposed on land, to rivers, and to the sea. Discharging deep into the sea can, at some locations, minimise some of the environmental risks, particularly loss of land, displacement of people, and the threat of contamination of productive land and river fisheries. Impacts on marine fisheries and other marine resource use can be minimised by site-specific placement of a tailings outfall. This will be designed to generate a coherent density current flow of tailings to a final deposition site from which there will be no reactivation into the water column.

In the development of a mine, the developers, government regulators and involved citizens must be prepared to obtain and review a series of sets of information, and to proceed sequentially in a series of stages. These stages

are: Exploration, Development (Feasibility Assessment, Blueprinting, Construction and Commissioning), Operations and Closure. These Guidelines provide checklists of action for each stage.

Numerical guidelines are provided for a suite of common metal contaminants. These are based on values calculated from case histories in both the United States and Canada, and from a theoretical procedure, Equilibrium Partitioning (EP).

The Canadian and US data provide two sets of values: (1) below which toxic impacts are unlikely; and (2) above which such impacts are likely. The EP method calculates a sediment value in equilibrium with the pore water so that water quality criteria are not contravened. There can be substantial differences in the Guideline values calculated by the different methods. The values to be used at a particular site must be decided by the Regulatory Agency.

Two other questionnaires are also provided. One is for administrative information and should be compiled by the relevant Regulatory Agency. This list includes information such as relevant regulations, permitting procedures, other involved government agencies, and local resource owners and users. The second questionnaire details the kinds of specific information which a Regulatory Agency will require from a developer in the preliminary stages of a possible mine development. This questionnaire can also be modified, and completed by mines already operating, so that Regulatory Agency files can be periodically updated.

Part One

Mine Development and Tailings Disposal

1

Introduction

1.1

Overview

The objectives of this document are to summarise knowledge about tailings disposal in tropical coastal areas, provide key technical references, and provide checklists of appropriate action for mine development in the South Pacific region.

This manual is divided into two parts, with Part One containing the three main chapters. Chapter 1 (Introduction) outlines the basic mining and milling processes and the associated production of waste rock and tailings. It also provides a broad outline of environmental risks commonly associated with tailings disposal; licensing procedures and the gathering of environmental data; and other regulatory issues.

Chapter 2 (Description of procedures) describes the sequence of actions to be taken by a mine developer and a Regulatory Agency at each of the main stages of mine development from exploration to closure.

Chapter 3 (Numerical guidelines) provides copies of environmental guidelines for the mining industry compiled from several sources. These tables should be used as checklists indicating environmental risks about which information is needed prior to decisions permitting a mine to proceed.

Part Two consists of two environmental questionnaires. One details administrative information to be compiled by the relevant Regulatory Agency. The other details the kinds of specific information which a Regulatory Agency will require from a developer in the preliminary stages of a possible mine development. As noted in the executive summary, this questionnaire can also be modified for use by operating mines.

1.2

Production of tailings: the mining-milling process

The mining process for metal extraction usually consists of two parts: mining and milling. The *mining* component is the extraction of metal-bearing ore from rock. The *milling* component generally crushes, grinds and extracts a concentrate in a series of mechanical and/or chemical processes.

Figure 1.1 illustrates these two processes. It also shows that at both stages waste is produced. Mining almost always involves the extraction of unwanted non-metal-loaded rock in order to reach the ore. Such waste rock has to be placed somewhere nearby.

Milling produces large amounts of finely ground waste from which the metal concentrate has been separated. This waste is

called tailings, and must also be placed somewhere nearby or otherwise disposed of.

The scale of these two types of waste production can be enormous and is illustrated by Island Copper Mine in Canada (Plate 1). For every tonne of copper concentrate produced, about 50 tonnes each of waste rock and tailings have to be moved away from the mining-milling process. Island Copper at peak operation extracted about 90,000 tonnes per day of rock and ore, to produce about 1000 tonnes per day of concentrate and 48,000 tonnes per day of tailings. The balance of about 41,000 tonnes per day was waste rock. Plate 1 shows the waste rock dumps and their reclamation. The tailings are underwater.



Plate 1 Island Copper Mine, Rupert Inlet, British Columbia, Canada

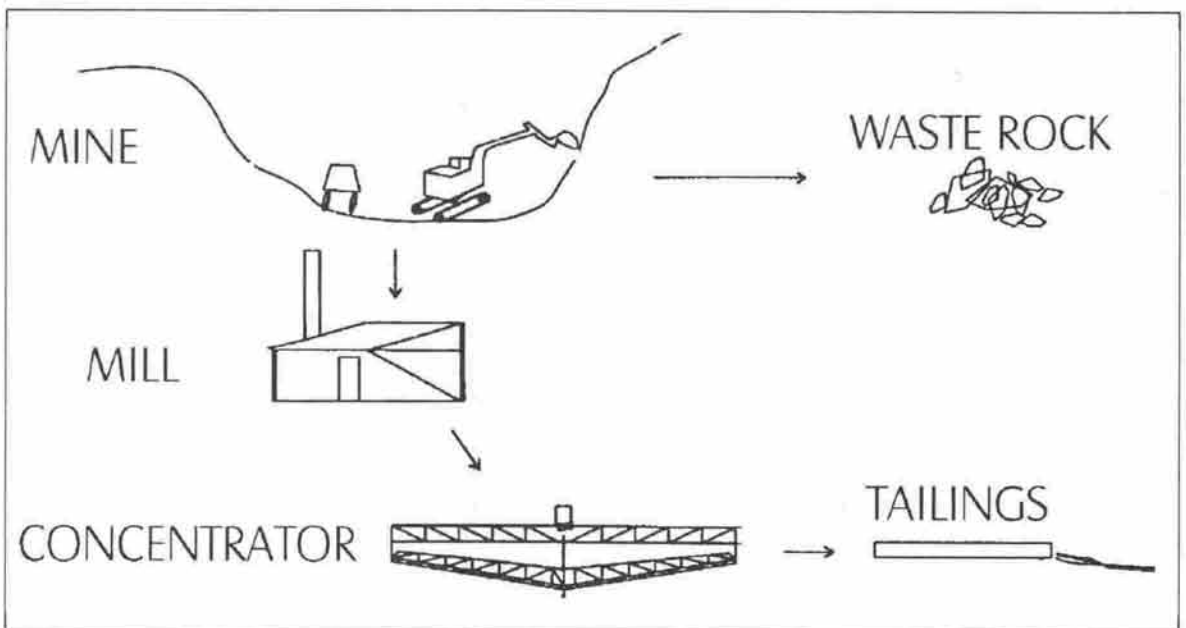

Figure 1.1 Waste produced from mining

Key reference

The process of milling and tailings production is described by G.W. Poling in an article within a 1995 review of tailings disposal at coastal and island metal mines. The whole review, *Submarine Tailings Disposal*, is referenced throughout these Guidelines as MG&G (1995). It comprises vol. 13, combined issues 1 and 2 of *Marine Georesources and Geotechnology*, and is available from the publishers Taylor and Francis, Suite 101, 1900 Frost Rd., Bristol, PA, USA 19007, Fax 215785 5515. All agencies interested in mine development should obtain a copy of this review, and use it as a reference document in association with these Guidelines.

Plates 2 to 4 show how the pit at Bougainville Copper Mine (PNG) is situated within a valley, with tailings discharged to a river. The Bougainville mine produced 80,000 tonnes of waste rock and 120,000 tonnes of tailings each day. Plates 5 and 6 show a smaller mine, extracting gold and silver, producing 15,000 tonnes of tailings per day.



Plate 2
A mine pit in an interior valley has removed land from other resource use at least temporarily.



Plate 3
A river has been used for tailings discharge, and the flow completely fills the valley.



Plate 4
At the sea edge. Without an engineered outfall discharging to depth (see Plate 6), tailings will spread and have a significant impact on the coastline.



Plate 5
A mine pit engineered for reclamation.



Plate 6
A seawater-mix de-aeration tank for submarine tailings discharge.

1.3 Environmental risks

Overview

The environmental risks associated with the disposal of mine tailings are considerable. Placing vast quantities of waste rock or tailings in the environment smothers habitat, changes watercourses and displaces people. It can contaminate air, land and water, and otherwise affect neighbouring and especially downstream uses. Low-grade marginal ore may be stockpiled for eventual use but at final closure may remain unused, hence wasted and also occupying land.

These and other environmental risks must be eliminated by good engineering, or at least minimised (mitigated) to levels acceptable socially—to the local people and to the nation.

Underlying principles of Guidelines

The mitigation principle adopted in these Guidelines is that any social costs must be minimal. They must be minimal in the short term, while the mine is being developed, built and operated. They must be minimal in the long term, in the sense of costly social changes continuing after closure of the mine. The Guidelines accept a number of operational principles:

1. The mine will exist for a predicted period of time, after which land may be reclaimed, although not necessarily for the same use as before.
2. Financial compensation to affected persons may be able to offset disruption of people's use of land, and/or their displacement.
3. The costs of government action through its Regulatory Agency can be borne by the industry concerned by taxation, fees or levies through an appropriate fiscal channel.

Environmental risks and mitigation procedures in the disposal of waste rock are well known to the mining industry. Essentially, the risks consist of smothering habitat, changing watercourses, loss of other resources, and contamination. The scale of habitat smothering, hence mitigative engineering and/or compensation needed, can be readily identified. The scale and nature of contamination and loss of resources are far less readily identified, but must be attempted. These

Guidelines concentrate on the environmental risks in tailings disposal.

Common methods of tailings disposal and associated environmental risks

Tailings are usually disposed of in the following ways:

1. *Returned to pit, or underground.* With this method, tailings are returned to their source. However, as the volume of rock increases following milling, not all of the tailings can be returned to the pit or underground.
2. *Impoundment behind a dam on land.* With this method, usable land is covered, and in areas with high earthquake risk and torrential rain there is high risk of collapse. Generally it needs a water cover to minimise Acid Rock Drainage (ARD), that is, engineering into an artificial lake or reservoir (see MG&G 1995).

Engineering associated with dam impoundment is described by Caldwell and Welsh (1982) in the book, *Marine Tailings Disposal*. Although this book is now out of print, a limited number of copies are available from the South Pacific Regional Environment Programme (SPREP), and can be obtained by interested parties on request. The article describes engineering for tailings disposal in "rugged, high precipitation environments" in the United States and Canada, and modification has to be made for application to the tropical conditions of the South Pacific.

3. *Discharge to a river, with uncontrolled dispersal downstream.* This disposal method usually has the greatest environmental impact, due to lack of control of eventual spread during downstream flooding, and the highest risk of ARD due to weathering. Bougainville Copper Mine provides an example, from the South Pacific region, of the environmental risks associated with river disposal of tailings (see Plates 2 to 4).
4. *Discharge to a lake.* If a lake of sufficient volume is available, this can be considered as a means of tailings disposal. Outfall design can minimise the almost inevitable effects of

water turbidity and loss of uses during discharge. Long-term contamination may be reducible so that uses can be restored after mine closure.

5. *Discharge to the sea.* Disposal of tailings to the sea from island and coastal mines can minimise environmental impact, provided an outfall is suitably engineered to discharge tailings as a density current flowing by

gravity (as a submarine river) to a designated final, stable deposition site. In general, this site will be deep underwater, below the shallow water productive fisheries zone. The discharge point, the flow of tailings and the final deposition site must have minimal risk of being disturbed by turbulence, resuspension of tailings, and upwelling to surface (see Plate 6).

1.4 Regulation and these Guidelines

Overview

Guidelines are statements of desirable actions and targets. They are not objectives, standards or regulations to be enforced. They are statements which provide information to any interested parties about environmental risks.

This manual provides guidelines for use in the South Pacific region by Regulatory Agencies and the mining industry. It is expected that they will also be read and used by interested citizens as checklists of potential actions. The Guidelines are for use in the following:

- Developing and reviewing applications for mining exploration licenses
- Developing and reviewing both preliminary and detailed proposals for new mine development
- Writing and reviewing Environmental Impact Assessments (EIAs) at operating mines

Sequence of procedures for mine development

The principle is accepted here that environmental protection procedures should be sequenced. Following approval of an exploration license, developers of new mines should collate available environmental information (feasibility report) for a preliminary decision by the Regulatory Agency whether the development is environmentally viable in principle.

Second, if the preliminary collation indicates that environmental impacts are potentially acceptable and able to be mitigated, requirements can then be set for detailed, new

environmental data gathering (in blueprinting phase), leading to a final licensing decision.

With this sequencing, mine developers can bring readily available information together for the preliminary decision (approval in principle).

If this is favourable, then the more time-consuming and expensive procedure of gathering site-specific environmental data gathering can proceed.

Environmental Impact Assessments (EIAs) are to be undertaken by the mine developers (for mine proposals and during exploration) or by their consultants. Before development is finally licensed, a formal and comprehensive Environmental Impact Assessment (EIA) should have been compiled and made available to the Regulatory Agency and to the public. Each nation's Regulatory Agency can decide how to use the information provided at any stage in the mine development.

Environmental data are also needed from mines in operation. This may be available already from the mines, or more may be needed. Extra information may be available on a voluntary basis, or may require appropriate new legislation or regulations.

Using these Guidelines

Copies of this manual and the associated factsheet are available from SPREP to:

- applicants for exploration licences
- mine developers and operators
- all government agencies with an involvement in the licensing process
- the public, especially representatives or landowning or land-using communities.

At any mine development, representatives of the industry, the Regulatory Agencies, and user communities should expect to meet routinely for discussion of the various items and of progress in their implementation.

Other regulatory issues

Separation of responsibilities. In general, it is desirable to have the environmental Regulatory Agency in a ministry separate from the ministry responsible for mining development and worker safety. This is so that the balance between economic development and long-term environmental damage with costs to the nation may be considered at the ministerial level.

Expertise in regulatory review, and associated costs. The Regulatory Agency may wish to retain environmental consultants to conduct a part or all of its reviews. The consultants retained should have prior experience with mining EIAs in the tropics.

Note that a mine developer can be required to

meet Regulatory Agency costs for appraising the development. It may be necessary to introduce new legislation or regulations to require this. The funds provided may be by a grant directly to the Regulatory Agency, or by some other procedure following government accounting practice. The Regulatory Agency can then dispense the funds to meet staff costs, or the costs of contracting out the reviews and site visits to their retained environmental consultants, or some combination of these two procedures.

Experience in mine development and regulation. It should be noted that there is considerable experience with mining development and regulations in Papua New Guinea, and within the umbrella organisation of the South Pacific Regional Environment Programme (SPREP). Countries with little prior experience in mine development can draw on this experience by having their Regulatory Agencies contact experienced officials from Papua New Guinea and SPREP.

2 Description of Procedures

2.1 Overview

The development and operation of a mine has six stages:

1. Exploration
2. Development — Feasibility assessment
3. Development — Blueprinting
4. Development — Construction and commissioning

5. Operations

6. Closure

The procedures and responsibilities relevant to the developer and the Regulatory Agency at each stage of the process are described in the following sections.

2.2 Exploration

Responsibilities of the Developer

1. Applies for an exploration licence, and provides preliminary information on existing landowners and resource users in the area under application.
2. Receives copy of mining environmental guidelines.
3. Cooperates with the Regulatory Agency in consultation with landowners and resource users.
4. Receives or is refused exploration licence.
5. Complies with requirements if the licence is received.

—
Note: Contravention of an exploration licence will give a poor impression regarding the holder's commitment to following guidelines for a consequent mine.

Responsibilities of the Regulatory Agency

1. Receives application for the exploration licence.
2. Provides applicant with copy of mining environmental guidelines.
3. Approves or rejects application for an exploration license following established procedures, including consultation with and approval from (with compensation if necessary) any affected land users.
4. If approval is given, applies usual national licensing conditions, including requirement (if appropriate) not to disturb specific watercourses or downstream users.

2.3 Development: Feasibility assessment

Production of a feasibility report, containing a conceptual mining plan and a preliminary environmental screening

Responsibilities of the Developer

1. Develops a conceptual mine plan and a preliminary Environmental Impact Assessment (EIA) for a feasibility report, identifying sources of previously available information and any new data obtained. The feasibility report:
 - ▼ describes ore body; its extent and chemical composition
 - ▼ describes expected milling and concentration processes, identifying process chemicals in general terms, and mill location
 - ▼ identifies sources of water for mine use and rates of removal, and provides relevant hydrological data on the water sources
 - ▼ identifies power demands and energy sources (for example, hydropower, oil generation, etc.)
 - ▼ identifies general location of access roads, worker accommodation, and other infrastructure areas
 - ▼ identifies expected wastes including types (for example, tailings, waste rock, stack emissions, sewage, etc.), rates of production, total amount during mine lifetime, chemical composition (including process chemicals and known high-risk trace elements such as mercury, lead, cadmium), and ARD (Acid Rock Drainage) potential
 - ▼ identifies site(s) for marginal ore stockpiling, maximum amount expected, and area(s) affected during mine lifetime
 - ▼ identifies waste disposal systems and receiving areas for wastes
 - ▼ indicates potential social consequences from resource losses (for example, community relocation, fishery losses to subsistence users or market fisheries, etc.)
 - ▼ details information from baseline environmental studies undertaken by the developer including the following:

- weather data, relevant hydrological data, marine current and tidal data, and identifies sources of information
 - preliminary models of waste disposal, including dilution, dispersion and assimilation of liquid wastes, identifying eventual regions of final deposition
 - inventory of other local resources (for example, other minerals, fisheries, gardens, sago stands, etc.) and identifies which are at risk
 - basic ecosystem parameters including relevant environmental properties, plant and animal communities, and endangered species
 - inventory of sites of traditional importance to local residents
2. Provides initial funds for needed actions by the Regulatory Agency.
 3. Explores with community representatives the form of a community review group to meet routinely during development and operations.
 4. Prepares the feasibility report and submits it to the Regulatory Agency. This is to include an executive decision understandable by the public.

Responsibilities of the Regulatory Agency

1. Reviews the feasibility report, and may request further information to decide whether the development may proceed to detailed design stage (Blueprinting) and final decision.
2. Defines environmental impacts of initial concern.
3. Identifies remedial action needed to minimise resource conflicts.
4. Requests any further assessment information needed.
5. Approves the conceptual plan in principle, subject to remedial action needed, or denies permission to proceed further.

Note: Approval in principle is not the final permission to proceed. More detailed investigation of risks may show that some are unacceptable.

2.4 Development: Blueprinting

Development of detailed mining plan with environmental risks identified and remedial action proposed

Responsibilities of the Developer

1. Develops a detailed mine plan; gathers, assembles and reports detailed information to support the design. This detailed mine plan:
 - ▼ identifies wastes based on pilot plant ore processing tests (including chemical composition and rates of production), total waste production during mine lifetime, and expected major changes in type and rate during mine lifetime
 - ▼ details water extraction systems specifying sources, extraction procedures, pipelines, rates of use with expected changes during mine lifetime. Updates initial hydrological data previously provided
 - ▼ details waste disposal systems including design of pipelines, outfalls, tailings dams and emergency ponds
 - ▼ details energy demands through mine lifetime, and provides detailed plans for meeting energy demands, including necessary construction.
 - ▼ details receiving areas for wastes, and updates weather and tidal/current data
 - ▼ describes ARD generation potential and mitigation measures
 - ▼ provides detailed model of waste dilution, dispersion and assimilation, identifying final deposition of wastes, relative amounts in different locations, environmental destination of toxins, and risks of resuspension and reactivation
 - ▼ provides detailed pre-operational inventory of resources at risk, with appropriately timed measures of seasonal variability. This monitoring of variability is to be initiated two or more years in advance of construction. Results are to be presented in a form which allows subsequent comparable monitoring during operations
 - ▼ demonstrates comparison procedures by showing changes between sets of

pre-operational data from each sampling station

- ▼ provides a detailed monitoring plan, describing parameters to be measured, methods of measuring, and personnel to undertake the monitoring. Estimates costs based on documented cost experience, including costs to the Regulatory Agency for its review of monitoring data
 - ▼ details environmental constraints to be implemented during construction and commissioning
 - ▼ provides remedial plan for social impacts, including relocation proposals and compensation if appropriate
 - ▼ describes concept for eventual closure plan, including the types of habitat and resource use as reclamation objectives
 - ▼ identifies plans for reclamation of impacted areas, with details of start-up timing and procedures
2. Conducts initial community group meetings. Documents meeting proceedings, resource uses, and formal social impact assessment surveys where conducted.
 3. Reports environmental data in the form of a comprehensive EIA one year prior to desired start-up date.
 4. Provides further funds to meet costs of Regulatory Agency reviews.

Responsibilities of the Regulatory Agency

1. Reviews all documents provided, and may request further information for final decision whether mine may proceed or not.
2. Defines impacts of concern and specifies environmental controls (for example, location, rates and composition of waste discharges).
3. Reviews and approves details of tailings disposal system (for example, to sea by pipeline, or to land with a tailings dam).
4. Identifies remedial action needed and compensation costs, and estimates own costs for action.
5. Identifies any further assessments needed.

6. Identifies environmental constraints during construction and commissioning.
- Construction constraints.* Streams and river disturbances to be minimised. Where temporary diversions and turbidity increases are inevitable from construction, then licensed timing of such disturbances should be specified. (Any permanent diversions, turbidity increases, etc. need downstream user approval, and compensation as part of the approval process.)
- Commissioning constraints.* Defines toxin monitoring and bioassays, and specifies

frequency. Normally, only toxins of concern will need monitoring on the initial day of discharge, and thereafter weekly. Bioassays may be required if toxins exceed operational limits.

7. Approves the detailed design plan, or makes final decision to deny the development. Approval provides for authority for the Regulatory Agency to suspend operations immediately if constraints are violated, with appropriate appeal procedures.

2.5 Development: Construction and commissioning

Construction risks include changing flows of streams and rivers, hence causing downstream impacts. *Commissioning risks* include release of wastes at levels in excess of those permitted during operation

3. If constraints are violated, uses authority to stop construction immediately.

Construction

Responsibilities of the Developer

1. Ensures that the contractor follows environmental constraints imposed.

Responsibilities of the Regulatory Agency

1. Makes site visits and documents by photographic record, etc.
2. Checks for watershed changes or other resource losses, and social consequences.

Commissioning

Responsibilities of the Developer

1. Undertakes liquid waste toxin monitoring as required.

Responsibilities of the Regulatory Agency

1. Makes site visits and documents by photographic record, etc.
2. Checks for fish kills or other resource losses and social consequences.
3. If constraints are violated, uses authority to stop commissioning immediately.

2.6 Operations

The mine operator monitors the environmental impact of operations. The suggested initial frequencies below should be modified after experience of operations.

Responsibilities of the Operator

1. Undertakes all monitoring and reports.

Tailings

- Undertakes fish bioassays (monthly), measures flow rates (daily), suspended

solids content (weekly), specified dissolved toxins (monthly). Monitors tailings disposition (monthly) by chemical parameters, cores, sonar, etc.

Waste rock (marginal ore)

- Records deposition rates (daily), maps locations (quarterly), tests for ARD and sources (monthly).

Resource impacts

- *Habitat.* Measures dispersion and dilution of tailings plume, turbidity, dissolved

metals, tailings resuspension traps (quarterly)

- *Spills*. Immediately assesses extent of spill of any process chemicals and reports to the Regulatory Agency
- *Fisheries*. Documents yields, numbers, size, tissue bioaccumulation of trace toxins, for selected species (quarterly)
- *Ecosystem*. Benthos and plankton: measures standing crops, primary production rates, sediment toxin levels, bioassays, bioaccumulation of trace toxins for selected populations, at selected sites and times

Reclamation

- Documents ongoing reclamation, including new areas initiated, and monitors regrowth (quarterly).

Community review group

- Holds meetings as agreed, hears comments, documents proceedings and negotiates settlement of issues raised

Reporting and reviews

- Reports quarterly, plus immediate reports of any contravention of controls. Meets annually with regulators to discuss environmental concerns and negotiate annual funding for Regulatory Agency

Responsibilities of the Regulatory Agency

1. Reviews reports, and acknowledges receipt of reporting.
2. Undertakes spot tests of any monitoring parameter.
3. Undertakes spot checks of any monitoring procedure.
4. Requires reviews of operational, monitoring or reporting procedures.
5. Requires changes in operational, monitoring or reporting procedures, including changes in their frequency.

2.7 Closure

Temporary closures

May be required for maintenance, inventory reduction, etc.

Responsibilities of the Operator

1. Monitors relevant environmental changes daily.
2. Monitors appropriate resource measures (see previous) especially turbidity.
3. Assembles information on ecosystem recovery in a form which is useful for development of final closure plan.

Responsibilities of the Regulatory Agency

1. Makes site visits, and obtains photographic records.

Final closure

Responsibilities of the Operator

1. Initiates development of closure plan five years in advance of intended closure.

2. Provides closure plan to Regulatory Agency for review and negotiation of closure bond. The closure plan has as objective the reclamation of land and waste deposits to productive resource use. The bond is to cover costs of any remediation subsequently needed.
3. Monitors recovery
 - *Habitat*. Turbidity, dissolved metals, tailings resuspension traps
 - *Fisheries*. Yields, numbers, size, tissue bioaccumulation of trace toxins
 - *Ecosystem*. Benthos and plankton populations and standing crops, primary production rates, bioaccumulation of trace toxins
4. Monitors social response to environmental recovery by continuing community group meetings and other social assessments.
5. Posts bond for implementation.
6. Reports annually.

**Responsibilities of the
Regulatory Agency**

1. Reviews closure plan, requires additional information if needed, and sets closure bond.
2. Reviews annual reports, and requires remedial measures charged to bond if needed.
3. Approves eventual termination of monitoring.

Overview

The documents referenced here, with selected tables reprinted, provide recent numerical guidelines developed by various Regulatory Agencies.

The tables are provided as a summary of information. Values for pollution control purposes should be determined for each specific site, based on such factors as the need for a high safety factor due to population density, the trace metal composition of the ore body, and ambient levels within soils and sea sediments.

It should be noted that there are differences between the various source documents in the significance of the values listed, and actual values for similar situations. These differences represent different risk-reduction concerns of different Regulatory Agencies, varying data sources, and varying approaches to data analysis.

The operational principle in the use of these data is to obtain and compare the values for the

metals of concern at particular sites. Once such a table has been developed, then the values can be put into the context of site geochemistry, and other resource use. From this context, limiting values for release to the environment, and to environmental sinks such as seabed deposits and fishery species, can be developed.

The US NOAA figures

The US National Oceanic and Atmospheric Administration (NOAA) distributed a report (Long & Morgan 1991) documenting an accumulation of sediment trace metal concentrations with and without biological effects. These have been condensed and modified slightly by Long et al. (1995).

Table 3.1 provides the data on trace metals in sediments as published in 1995. Values are based on sediment dry weights, mg kg⁻¹, that is, ppm.

Figure 3.1 illustrates the meaning of the acronyms used. ERL is the concentration below which there is little likelihood of biological

Chemical	Guidelines		Per cent (ratios) incidence of effects ¹		
	ERL ²	ERM ³	<ERL	ERL-ERM	>ERM
arsenic	8.2	70.0	5.0 (2/40)	11.1 (8/73)	63.0 (17/27)
cadmium	1.2	9.6	6.6 (7/106)	36.6 (32/87)	65.7 (44/67)
chromium	81.0	370	2.9 (3/102)	21.1 (15/71)	95.0 (19/20)
copper	34.0	270	9.4 (6/64)	29.1 (32/110)	83.7 (36/43)
lead	46.7	218	8.0 (7/87)	35.8 (29/81)	90.2 (37/41)
mercury	0.15	0.71	8.3 (4/48)	23.5 (16/68)	42.3 (22/52)
nickel	20.9	51.6	1.9 (1/54)	16.7 (8/48)	16.9 (10/59)
silver	1.0	3.7	2.6 (1/39)	32.3 (11/34)	92.8 (13/14)
zinc	150.0	410	6.1 (6/99)	47.0 (31/66)	69.8 (37/53)

Source: Long et al. 1995

¹ Number of data entries within each concentration range in which biological effects were observed divided by the total number of entries within each range.

² ERL = Effects Range (Low); level below which effects rarely occur

³ ERM = Effects Range (Medium); level above which effects will probably occur

Table 3.1 Guideline values for trace metals (ppm, dry wt) and per cent incidence of biological effects in concentration ranges defined by the values, ERL and ERM

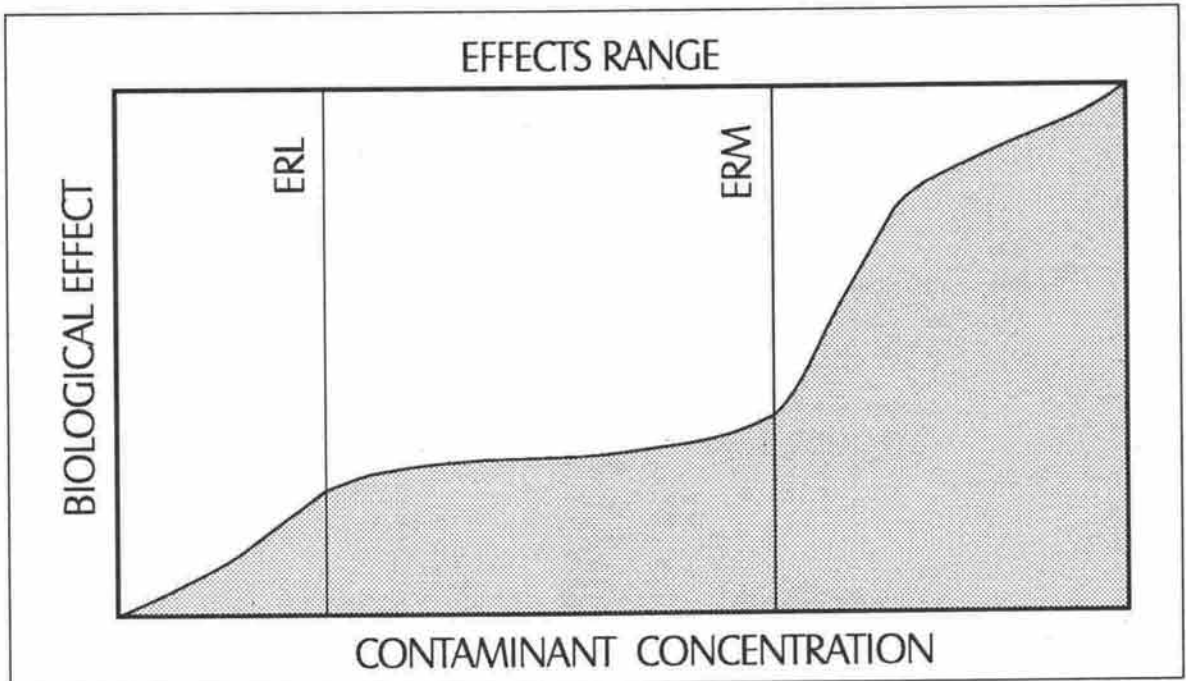

Source: Modified from Long & Morgan (1991)

Figure 3.1 The potential for biological effects of sediment-sorbed contaminants tested in the US National Status and Trends Program

effects. ERM is the concentration above which biological effects are probable. Between ERL and ERM values there is some possibility of biological effects. It should be noted that these are not absolute values. Below ERL values biological effects sometime occur, although rarely (see column headed \leq ERL in Table 3.1). Above ERM values, biological effects by no means always occur (see column headed \geq ERM). The ERM is a median value. Half the cases considered above the ERM did not show effects. Also, the data are from mainland United States, not world wide.

The Environment Canada figures

Environment Canada has distributed a draft report on trace metal sediment concentrations (Environment Canada 1994). Tables 3.2 and 3.3 from the report provide values for marine and fresh water respectively. They are quite similar. There are two indicator values: TEL and PEL. TEL is the Threshold Effect Level below which adverse effects are expected to occur rarely. PEL is the Probable Effect Level which like the ERM is a median value and defines the level above which adverse effects are predicted to occur frequently. The values refer to the total

concentration of a chemical in surficial sediment (that is, upper few centimetres) on a dry weight basis. They are based on standardised calculation procedures from a data set, apparently entirely Canadian. Values are based on sediment dry weights, mg kg^{-1} ppm.

For comparative purposes, the Canadian TEL appears to be similar to the US NOAA ERL, and the PEL similar to the ERM. Note that a further set of guidelines developed in the semi-tropical state of Florida uses the TEL and PEL terminology based on US and Canadian cases (MacDonald 1994).

The Equilibrium Partitioning approach

Webster and Ridgway (1994) have refined an approach to setting sediment guidelines based on water quality criteria. This approach is called equilibrium partitioning (EP). The argument is that there is much more information available on water quality than for sediment quality. The sediment standard is therefore taken as the concentration in the sediment, in equilibrium with the interstitial water, that does not give rise to a concentration in the water that would breach the water quality criterion for that contaminant.

Chemical	TEL ¹	PEL ²	≤TEL%	< >%	≥PEL%
arsenic	7.24	41.6	3	13	47
cadmium	0.68	4.21	6	20	71
chromium	52.3	160	4	15	53
copper	18.7	108	9	22	56
lead	30.2	112	6	26	58
mercury	0.13	0.7	8	24	37
nickel	15.9	42.8	3	8	9
silver	0.73	1.77	7	10	60
zinc	124	271	4	27	65

Table 3.2
Draft Canadian Guidelines,
and incidence of adverse
biological effects in
concentration ranges defined
by values for marine
sediments, TEL and PEL
(Values in mg kg⁻¹; ppm)

Source: Environment Canada 1994

1 TEL = Threshold Effect Level; level below which adverse effects are expected to occur rarely

2 PEL = Probable Effect Level; level above which effects are predicted to occur frequently

Chemical (mg kg ⁻¹ ; ppm)	TEL	PEL	≤TEL%	< >%	≥PEL%
arsenic	5.9	17.0	5	25	12
cadmium	0.596	3.53	11	12	47
chromium	37.3	90.0	2	19	49
copper	35.7	196.6	4	38	43
lead	35.0	91.3	5	23	42
mercury	0.174	0.486	8	34	36
nickel	18.0	35.9	4	18	44
zinc	123.1	314.8	5	32	36

Source: Environment Canada 1994

Table 3.3 Draft Canadian Guidelines and incidence of adverse biological effects in concentration ranges defined for fresh water sediments

Table 3.4 provides trace metal sediment values derived from the extensive set of US Environmental Protection Agency (EPA) water quality criteria. The claim is that these values can be accepted as guidelines since they imply a theoretically "safe" sediment concentration. The authors state that this concept has to be used cautiously. Values are based on a different unit than the two above systems, that is, on mg kg⁻¹ (ppm) carbon.

Chemical	EPA water quality	Sediment criteria (mg kg ⁻¹ carbon)
arsenic	6.3	819.0
cadmium	12.0	768.0
copper	2.0	3400.0
lead	8.6	3268.0
mercury	0.1	0.8
zinc	58.0	19140.0

Source: Webster & Ridgway 1995

Table 3.4 Sediment criteria for six elemental contaminants derived from water quality criteria and equilibrium partitioning coefficients

Comparison of values

Table 3.5 compares the three sets of values in the previous tables. Note that the EP values are for a 1 per cent carbon level, assumed to be a comparable level between sediments in this context.

Chemical	ERL	TEL	ERM	PEL	EP Criteria
arsenic	8.2	7.24	70	41.6	8.19
cadmium	1.2	0.68	9.6	4.21	7.68
chromium	81	52.3	370	160	—
copper	34	18.7	270	108	34
lead	46.7	30.2	218	112	32.68
mercury	0.15	0.13	0.71	0.7	0.008
nickel	20.9	15.9	51.6	42.8	—
silver	1	0.73	3.7	1.77	—
zinc	150	124	410	271	191.4

Source: Environment Canada 1994

Table 3.5 Guidelines for marine sediments comparing values from Tables 3.1, 3.2 and 3.4 (expressed as 1 per cent carbon)

References

- Caldwell, J.A. & Welsh, J.D. 1982. Tailings disposal in rugged, high precipitation environments: An overview and comparative assessment. Chapter 1, pp. 5–62, in *Marine Tailings Disposal*, ed. D.V. Ellis, Ann Arbor Science, Ann Arbor, USA, 368 pp.
- Ellis, D.V. 1989. *Environments at Risk: Case Histories of Impact Assessment*. Springer-Verlag, Berlin. 329 pp.
- Ellis, D.V., Pedersen, T.F., Poling, G.W., Pelletier, C. & Horne, I. 1995. Review of 23 years of STD: Island Copper Mine, Canada. *Marine Georesources & Geotechnology*, vol. 13, pp. 59–99.
- Environment Canada. 1994. Draft interim sediment quality assessment values. Manuscript report, no. ECD, p. 4.
- Long, E.R. & Morgan, L.G. 1991. The Potential for Biological Effects of Sediment-Sorbed Contaminants Tested in the National Status and Trends Program. NOAA Technical Memorandum, NOS OMA 52, Seattle. 175 pp. + appendices.
- Long, E.R., Macdonald, D.D., Smith, S.C. & Calder, F.D. 1995. Incidence of adverse biological effects within ranges of chemical concentrations in marine and estuarine sediments. *Environmental Management*, vol. 19, no. 1, pp. 81–97.
- MacDonald Environmental Sciences Ltd. 1994. *Approach to the Assessment of Sediment Quality in Florida Coastal Waters*, 4 vols. Florida Department of Environmental Protection, Tallahassee, Florida, USA.
- MG&G. 1995. Submarine Tailings Disposal. *Marine Georesources and Geotechnology*, vol. 13, nos 1 & 2, 233 pp.
- Webster, J. & Ridgway, I. 1994. The application of the equilibrium partitioning approach for establishing sediment quality criteria at two UK sea disposal and outfall sites. *Marine Pollution Bulletin*, vol. 28, no. 11, pp. 653–661.

Part Two

Environmental Questionnaires

Preliminary Information to be Compiled by The Regulatory Agency for a Mine Development

- 1 List any legislation that affects the mine development and operations. Obtain copies and file.

- 2 List any regulations developed under the legislation. Obtain copies and file.

- 3 List other ministries and divisions which will be involved, with contact officers.

- 4 Assemble or write up descriptions of the permitting procedures necessary for:
— a. exploration _____

- b. actual mining _____

- c. final closure _____

- 5 Does any new legislation, or set of regulations appear to be needed? If yes, write up in draft form.

- 6 Who are, or will likely be, the representatives of local landowners and resource users affected by the mine? Provide name(s) and address(es).

Preliminary Information to be Compiled by an Applicant for a Mining Licence

Questionnaire can be modified for use with mines currently in operation.

Please respond to the following questions with information currently available
within 30 days of receiving this questionnaire.

This questionnaire was mailed on _____ (date)

to _____

(name and address of the mine developer)

Attention of _____

(name, position)

Your response should be addressed to: _____

(name and address of official to receive the response)

Please attach extra pages as necessary, indicating where additional material, maps etc have been
provided.

1 Name of the proposed mine _____

2 Contacts

a. Developing company

Name _____

Local address _____

Phone / Fax / Internet, etc. _____

b. Local senior official

Name _____

Title _____

c. Senior environmental official

(if different from local senior official)

Name _____

Official position _____

Address for further correspondence _____

Phone / Fax / Internet, etc. _____

d. Shareholders

*(list major national and foreign shareholders
and percentage ownership)*

3 Mine site

- a. General location within the nation _____
(obtain national map and mark to show island and location)
- b. Specific location _____
(use property designation, obtain copy of best available topographic map and aerial photographs, then mark location)
- c. New roads needed _____
(locate on the map provided, noting river crossings)
- d. Worker facilities needed _____
(will there be a townsite, or camp with single-men's quarters only, etc.)

4 Climate, geography and geology

- a. Rainfall data, and summary of seasonal variation _____

- b. Topography and drainage patterns _____

- c. Seismic activity and earthquake history _____

- d. Geology and faulting _____
(obtain best available map)

5 Ore body

- a. Extent of ore body in hectares _____
(estimate land surface area over the ore body, mark on the best available map, and provide a three-dimensional diagram showing drilling depths to date, etc.)
- b. Chemical composition
(provide latest available date, noting date)
Major ore body minerals _____
Residual valuable minerals _____
Heavy metal contents (assays) _____
ARD (Acid Rock Drainage) potential _____
Levels of potentially toxic trace elements _____
(if not detected, state type of analysis used and give lowest level of sensitivity)

lead	
cadmium	
mercury	
arsenic	
others	

6 Mining operations

- a. Type: open pit underground
If both, in what sequence? _____
- b. Total tonnages
Ore _____
Waste rock: *hard rock* _____ *soft rock* _____
Low-grade ore (temporary stockpile) _____
- c. Mining rate: *initial* _____ *maximum during mine lifetime* _____
- d. Expected lifetime of mine in years _____

7 Mill processes

- a. Type of mill proposed _____
 - b. Water source _____
(show on map, with pipeline route to mill)
 - c. Water use rate (in litres/day): *first year daily* _____ *expected daily maximum* _____
 - d. Energy source: *hydropower* _____ *other* _____
- Location of electrical generation facilities _____
(provide map)
- Process chemicals used _____

Types	Rates of use /day

- e. Tonnage of tailings for disposal
 - solids: *first year tonnes/day* _____ *expected max. rate/day* _____
 - liquids: *first year flow rate/day* _____ *expected max. rate/day* _____
- f. Tailings grind specifications
 - Expected chemical composition of wastes _____
(identify test plant providing the results)
 - Liquid waste fraction
 - dissolved metal values* _____
 - residual reagents* _____
 - Solid waste fraction
 - trace metal levels* _____
 - potential for acid mine waste generation* _____ *(obtain supportive documentation)*

8 Area(s) to receive waste rock (overburden, etc.)

(provide information on all options, noting that placement of waste rock may require diversion of rivers)

- a. Location(s) of proposed waste rock dumps _____
(indicate on map, showing position(s) relative to the mine/mill complex; prioritise by number if appropriate)
- b. Estimate land area covered _____ hectares
- c. Chemical composition _____
(note potential for acid waste generation, who provided the assays, and levels of sensitivity for trace elements)
- d. Describe general plans for reclamation of waste rock _____

(describe plant species to be seeded, the habitat target to be reclaimed for use by local people, and the target uses of reclaimed habitat)

9 Areas to receive stockpiles of low-grade ore

(if stockpiling is likely, provide this information on map, showing positions relative to the mine/mill complex; note that none should remain after closure)

- a. Cut-off grade _____
- b. Locations and areas in hectares _____

- c. Chemical compositions and ARD potential _____

10 Areas to receive mill tailings

- a. Options being considered:
Impoundment by dam on land, or return to pit (underground) _____
Discharge to river or lake _____
Pipeline to coast with outfall for marine discharge _____
- b. Locations of options _____
(provide a map for each option being considered, showing route of any tailings pipeline, and location of discharge points)
- c. Area to be covered _____ hectares
(show on a map; if disposal is undersea, a hydrographic chart showing depths must be used)

11 Sewage facilities

(describe sewage facilities for townsite, single-men's quarters, and on-the-job toilet facilities; sanitary treatment facilities; and location, type and flow rate of final discharges)

12 Local land use and resources

(describe local land use and resources within a reasonable distance of mine site, mill site, tailings pipelines, on-land tailings impoundments, access roads, and tailings outfall (if submarine tailings disposal). Reasonable distance in this context means to a distance which might be affected by the mining operations. Mark location and extent of uses and resources on maps)

- a. Villages and isolated groups _____
- b. On-land resources: gardens, plantations, sago stands, other minerals, etc. _____

- c. Fishery resources identifying commercial, market and subsistence _____
(include river fisheries and marine fisheries if submarine tailings disposal is an option. Fisheries includes fin-fish and shellfish)

- d. Is there any relevant documentation of local resources? _____
(if so, obtain copies)

13 Potential social impacts

(indicate locations on maps, and explain reasons)

- a. Note types of rights of traditional landowners and/or users
(for example, occupation, or use only)

- b. Show those areas subject to traditional use and inheritance that will be irreversibly altered by the mine *(explain)*

- c. Locate and describe archaeological sites, and sites of traditional importance _____

14 Public Information

- a. Has information about the development been made available to the public? _____
(if yes, describe how information provided and list documents)

- b. List of public meetings held and attendance _____

- c. Has any schedule been developed for routine meetings with the public or representative groups? _____ *(provide details)*

15 Other relevant information
