



Vulnerability Assessment for Accelerated Sea Level Rise

Case Study: Majuro Atoll, Republic of the Marshall Islands

P. Holthus, M. Crawford
C. Makroro and S. Sullivan



Vulnerability Assessment of Accelerated Sea Level Rise

Case Study: Majuro Atoll, Marshall Islands

Holthus, P.
Project Officer (Scientist), SPREP

Crawford, M.
Republic of the Marshall Islands
Environmental Protection Authority

Makroto, C.
Assistant Chief Planner
Republic of the Marshall Islands
Office of Planning and Statistics

Sullivan, S.
Consultant Engineer
Sea Engineering, Inc.
Waimanalo, Hawaii

Funded by
United States National Oceanic and Atmospheric Administration (NOAA)

Apia, Western Samoa
December 1992

Foreword

In the Pacific, where the sea meets the shore, the forces of nature have always challenged human activities. These activities often increase the vulnerability of coastal areas to changes in sea level. The majority of the coastal areas now face erosion, flooding, loss of wetlands and contamination of water through inundation by rising seas. Coral and sand mining, destruction of mangroves and construction of dams and causeways all disturb the natural equilibrium processes that could help reduce the erosion, flooding and other potential impacts caused by accelerated sea level rise.

These environmental issues can be traced to high population densities and the continuing rapid rate of population growth in the atoll nations of the region. So, population problems are important and often associated with increased urbanisation and growth in the established population centres. Population growth and urbanisation will increase the number of people vulnerable to sea level rise. More stress on coastal resources, especially for the small islands,, would be due to human-induced climate change and changes in the sea levels.

The Framework Climate Change Convention was signed by the majority of SPREP member countries in Rio de Janeiro, Brazil 1992. This indicates one of the most serious environmental concerns in to the Pacific Region; global warming and sea level rise. In 1989, at Majuro in the Marshall Islands, during their Intergovernmental Meeting (IGM) on Climate Change and Sea Level Rise, the 27 member countries/governments mandated the SPREP Secretariat to coordinate activities and act as a clearing house in all climate change, sea level rise and associated issues. SPREP has shouldered the task, working closely with member governments and regional, international and non-governmental organisations.

SPREP is a member of the UNEP regional seas programme and is closely involved with the Intergovernmental Panel Climate Change's (IPCC) three working groups, especially the Working Group III (the Subgroup on the Coastal Zone Management). This is advantageous in addressing possible common environmental problems of small island states caused by accelerated sea level rise. In this area, SPREP has coordinated the studies of the atoll countries of Kiribati, Tuvalu, Cook Islands, Tonga and now the Marshall Islands. Studies on larger islands, using a common methodology developed by the IPCC in 1991 ("The Seven Steps to the Assessment of the Vulnerability of Coastal Areas to Sea Level Rise"), are now being conducted.

This case study for the Marshall Islands intends to:

- (i) assess the effects of Accelerated Sea Level Rise on Majuro Atoll;
- (ii) identify possible and appropriate response strategies to mitigate climate change and sea level rise;
- (iii) assess Majuro's vulnerability in relation to its ability to implement response options and to seek future assistance; and,
- (iv) be of use to other SPREP countries and region and international organisations.

I wish to express my gratitude and appreciation to the Government of the United States of America [United States National Oceanic and Atmospheric Administration (NOAA)] for funding the study, and for the publication and printing of the report.

Vili A. Fuavao
Director

Acknowledgements

This Vulnerability Assessment Case Study was a cooperative effort between the Republic of the Marshall Islands (RMI), Sea Engineering Inc. and the South Pacific Regional Environment Programme (SPREP).

The RMI Environmental Protection Agency (EPA) and Office of Planning and Statistics (OPS) provided the services of Ms Crawford and Mr Makroro, respectively. Important advice from OPS on economic development projections was provided by Mr. J. Lemari, Chief Planner and Dr. H. Gunasekera, Senior Economic Advisor.

Other RMI agencies which supported the study by providing information and insights include the Ministry of Foreign Affairs (MFA), the Ministry of Resources and Development (MRD), the Marine Resources Authority (MRA) and the Capitol Improvements Program. The National Task Force on Environmental Management and Sustainable Development, chaired by the Secretary of Foreign Affairs, provided oversight and conducted a survey of government leaders in support of the study. The Case Study is thus part of a larger national effort to incorporate environmental protection and management principles into development planning.

The valuable input of several other individuals is acknowledged: J. Alfred (Dep. Sec., Health Services), W. Allen (Sec. of Trans. and Comm.), K. Andrike (Sec. of Health Services), G. Benjamin (Chief of Trade, Industry and Tourism, MRD), C. Bigler (Sec., IOIA), D. Capelle (Sec. of Res. and Devel.), S. Fulk (Dir., Freight Div., Air Marshall Islands), E. Harding (Legal Counsel, RMIEPA), K. Helgenberger (Gen. Mgr., RMIEPA), J. Kabua (Sec. of MFA), M. Kaminaga (Under-Sec., MFA), B. Lanki (Chief Acct., Pac. International Inc.), C. Muller (Sec. of Social Services), V. Muller (Sec. of Finance), P. Peter (Chief, RMI Weather Bureau), and D. Wase (Dir., MRA).

The foresight of the Coastal Zone Management Sub-Group of the Intergovernmental Panel on Climate Change (IPCC) in realising the need for vulnerability studies and the value of a Common Methodology to conduct such studies is recognised.

The authors are grateful to NOAA for providing the funding which allowed the study to be undertaken. The assistance of Ms K. Ries and Mr B. Mieremet in project development and administration is specifically acknowledged, as well as the special efforts of Mr Mieremet in assisting to produce the Executive Summary. The generous assistance of Ms N. Schoux in typing and editing is acknowledged. The use of the Pacific Islands Network (PIN) office and the assistance of A. Orcutt (PIN Coordinator) in organising printing of the Executive summary are also acknowledged.

Our final thanks go to Wesley Ward and Chalapan Kaluwin at SPREP for the final layout and production of this report.

Contents

I	Summary	1
1.1	Introduction.....	1
1.2	Methodology and analysis conditions	1
1.3	Principal findings.....	4
II	Delineation of study area and specification of ASLR scenarios	5
2.1	Boundaries of case study area	5
2.2	Climate factors	14
2.3	Specification of ASLR scenarios.....	21
III	Inventory of study area characteristics	26
3.1	Characteristics of natural system.....	26
3.2	Characteristics of socio-economic system	36
3.3	Institutional arrangements	42
IV	Identification of non-climate change development factors	44
4.1	Human induced developments	44
4.2	Natural developments	48
V	Physical changes and natural system responses	51
5.1	Assessment of physical changes	51
5.2	Assessment of natural system responses	56
VI	Identification and specification of response strategies	58
6.1	Protection strategy.....	58
6.2	Accommodation strategy.....	60
6.3	Retreat strategy	60
6.4	No response strategy.....	61
6.5	Specification of responses	61
6.6	Response impacts on natural systems.....	70
VII	Vulnerability analysis	72
7.1	Impacts on socio-economic and ecological systems	72
7.2	Institutional implications of response options	73
VIII	Evaluation and interpretation	75
8.1	Evaluation of vulnerability profile and priority setting.....	75
IX	Conclusions and recommendations	76
9.1	Legislative, institutional and organisational considerations.....	76
9.2	Economic and financial considerations.....	78
9.3	Technical considerations.....	79
9.4	Cultural and social considerations	83

Tables

II-1 Study Area Characteristics9

II-2 Annual Percent Frequency of Wind Direction Versus Wind Speed for Majuro Atoll ... 15

II-3 Annual Maximum Fastest Mile Wind Speed at Majuro Atoll..... 15

II-4 Predicted Wind Speed at Majuro Atoll as a Function of Return Period 16

II-5 Annual Percent Frequency of Wave Height Versus Period for Majuro Atoll 17

II-6 Predicted Significant Wave Height for Majuro Atoll as a Function of Return Period .17

II-7 Seasonal Atmospheric Pressure by Percentiles for Majuro Atoll..... 18

II-8 Predicted Atmospheric Pressure for Majuro Atoll as
a Function of Return Period..... 18

II-9 Tropical Storms and Typhoons Within 150 N.M. of Majuro Atoll
and Kwajalein Atoll..... 20

II-10 Deepwater Design Wave Heights and Periods 22

II-11 Ocean Side Still Water Level Rise: ASLR = 0 22

II-12 Ocean Side Still Water Level Rise: ASLR=1 23

II-13 Ocean Side Still Water Level Rise: ASLR=3.3 23

II-14 Lagoon Side Still Water Level Rise: ASLR = 0..... 24

II-15 Lagoon Side Still Water Level Rise: ASLR=1..... 24

II-16 Lagoon Side Still Water Level Rise: ASLR=3.3..... 25

III-1 Natural System Characteristics..... 28

III-2 Shoreline with Shore Protection Structures 35

III-3 Socio-Economic System Characteristics 37

III-4 Marshall Islands Population and Rate of Increase 38

III-5 Land Use by Acreage..... 40

IV-1 Projected growth of GDP 46

V-1 Estimates of Shoreline Retreat Due to ASLR 51

V-2 Estimates of Dry Land Lost Due to ASLR and Erosion 52

V-3 Ocean Side Innundation Limits 53

V-4 Lagoon Side Innundation Limits 54

V-5 Flooding Area Estimates for Annual Event Conditions 55

V-6 Ocean Side Predicted Flooding Frequency 55

V-7 Lagoon Side Predicted Flooding Frequency 56

V-8 Reduction of Fresh Water Lens Cross Section Area Due to ASLR 56

VI-1 Design Wave Heights at Shore 62

VI-2 Generalised Revetment Crest Elevations Versus ASLR and Wave Conditions 62

VI-3 Estimates for three model designs to protect Kwajalein Atoll..... 63

VI-4 Kwajalein Shore Protection Costs per 100 Feet for 25-Year Life Cycle 64

VI-5 Selected Revetment Types Versus Wave Conditions 65

VI-6 Majuro Shore Protection Cost Estimates per 100 Feet for 25-Year Life Cycle 65-66

VI-7 Cost Estimates for Shore Protection: Study Areas 1 and 3..... 67

IX-1 Constraints Related to Implementation Feasibility 84

Figures

II-1	Marshall Islands Location Map	5
II-2	Majuro Atoll Location Map	6
II-3	Majuro Atoll and Study Area Location Map	7
II-4	Study Area Maps.....	8
II-5	Study Area 1 Map	10
II-6	Study Area 1 Map	11
II-7	Study Area 2 Map	12
II-8	Study Area 3 Map	13

Annexes

1.	Calculating Design Waves	87
2.	Calculating Still Water Level Rise	89
3.	Study Area Shoreline Inventory	91
4.	Land Area and Population Density by Island.....	95
5.	Calculating Erosion.....	96
6.	Calculating Wave Runup and Innundation	97
7.	Shore and Flooding Protection: Structure and Design Considerations.....	98

I. Summary

1.1 Introduction

The objectives of this Case Study are to:

- assess effects of Accelerated Sea Level Rise (ASLR) on the Republic of the Marshall Islands, as represented by four Study Areas on Majuro Atoll;
- identify possible and appropriate response strategies that would minimise the effects of ASLR; and,
- analyse Majuro's vulnerability in relation to its ability to implement response options and indicate what kinds of future assistance might be required to reduce vulnerability.

The Case Study has been undertaken using the methodology of the Intergovernmental Panel on Climate Change (IPCC).

The Case Study is intended to indicate as much as possible, based on existing information and limited field investigations, the likely impacts and possible responses to ASLR. It is not a comprehensive study or planning document. The information is intended for use by the Government of the Marshall Islands for conceptual planning and development of a programme to more fully assess the vulnerability to ASLR, and may assist potential sources of assistance in determining priorities and actions. In addition, the Case Study provides initial information to the IPCC for conducting a global assessment of the impacts and responses to climate change.

1.2 Methodology And Analysis Conditions

1.2.1 Report preparation

This Case Study followed, as much as possible, the methodology in the IPCC CZM Sub-Group document "The Seven Steps to the Assessment of the Vulnerability of Coastal Areas to Sea Level Rise: A Common Methodology. Revision No. 1" (IPCC, 1991).

The study was carried out by a multi-disciplinary team: M. Crawford and C. Makroro (socio-economic aspects), E. Nakasaki and S. Sullivan (oceanographic and engineering aspects), P. Holthus (ecological aspects). P. Holthus provided overall project coordination and report editing. With the assistance of B. Mieremet (NOAA), an Executive Summary was prepared for the Government of the Marshall Islands as part of their preparations for UNCED. This will also appear in the proceedings of the 3rd International Workshop of the IPCC CZM Sub-Group (Marguerita Island, Venezuela, February 1992).

1.2.2 Limits and assumptions

This Case Study is concerned only with the effects of Accelerated Sea Level Rise (ASLR), with the boundary conditions provided in the "Common Methodology", i.e. 1 foot (0.3 m) and 3.3 feet (1 m) by the year 2100. The study does not consider other aspects of climate change, e.g. increased frequency and intensity of extreme events, changes to currents or tides, increased temperature, changes in rainfall patterns, etc.

Specific information or models on tectonic movement and subsidence in the Marshall Islands were not available during the period of this Case Study, if they do exist. General information available did not indicate these land movements were occurring in the Marshall Islands. Thus it was considered reasonable to assume that tectonic movement and land subsidence to be nil for the purposes of the Case Study and these have not been taken into account. However, these factors are very important to the consideration of relative sea level rise and may not be inconsequential. Therefore they should be fully analysed in future ASLR studies in the Marshall Islands.

The oceanographic and engineering aspects rely on existing data for prediction of wave and water level conditions. Limited topographic and bathymetric information in particular has required that assumptions and extrapolations be made for land levels and bottom profiles.

Social and economic descriptions and predictions are based on existing data, little of which is specific for the four Study Areas chosen. Information was extrapolated in order to develop future economic growth and development scenarios.

The ecologic aspects of the Case Study focus more on the shoreline and shallow reef environment, due to the importance of these areas to ASLR response. The terrestrial environment of most of the land area of Majuro is fairly similar, except where modified by human activities.

It is not possible to factor in the response of coral reefs and reef/shore sediment budgets as part of this Case Study. It is assumed coral reefs will "keep up" with the ASLR boundary conditions given in the Common Methodology. However, impacts and stress from natural events, other aspects of climate change and/or human activities may invalidate this important assumption, thereby reducing the role of coral reefs in providing shore protection and producing sediment. In this case, impacts of ASLR will be greater than projected in the Case Study.

Data and information are presented in the form in which they are available, i.e. usually not in metric units. All monetary figures are in US \$.

1.2.3 Topographic and bathymetric information base

Topographic and bathymetric data are essential to undertaking a study on the effects of sea level rise. These data determine the level of detail and approach for much of the Case Study work. This kind of information is not available for most atolls and the Marshall Islands are no exception. Detailed information even for Majuro Atoll is limited. Detailed topographic data is available only for Study Area 1 (D-U-D area) and for the airport area (Study Area 3). For other Study Areas qualitative shoreline profile data was obtained during the field investigations.

The topographic and bathymetric information and data for the Case Study were:

- Topographic maps (1"=40') for the main urban area of Majuro (the D-U-D area with 1-foot contours (Surveyed in 1983).
- Majuro airfield and related facilities plan maps (1986).
- A 1:35,000 scale hydrographic map for Majuro Atoll (Defense Mapping Agency, 1976).
- Majuro Atoll Coastal Resource Atlas prepared for the US Army Corps of Engineers (Manoa Mapworks, 1989).

- Bathymetric data near the west end of the old runway, surveyed by Sea Engineering, Inc. (1983).
- Qualitative profile data obtained during field investigations.

Due to the lack of bathymetric data, reef flat and slope profiles on the ocean side are considered to have relatively uniform characteristics, with a reef flat elevation at about mean low water level and a steep slope seaward of the reef edge. A model profile was made using the existing bathymetric data near the west end of the old runway (Sea Engineering, Inc., 1983). Reef flat widths in Study Areas 1, 2 and 3 were estimated using aerial photos shown in the Majuro Atoll Coastal Resource Atlas (Manoa Mapworks, 1989). The reef width in Study Area 4 is considered the same as in Study Area 1.

Bottom profiles on the lagoon side were approximated using bathymetric data from the 1:35,000 scale hydrographic map (Defense Mapping Agency, 1976). Reef flat widths were measured from aerial photos in the Majuro Atoll Coastal Resource Atlas (Manoa Mapworks, 1989).

1.2.4 Shoreline characteristics

A field inventory of the Study Area shorelines was conducted. This included visual assessment of the shoreline, in which shoreline characteristics, composition, damage, existing erosion or accretion and erosion potential were noted qualitatively and a detailed photo log was kept. Profiles along shoreline were qualitatively surveyed in the Study Areas where no existing topographic data were available. The profiles were made in reference to sea water levels assuming that tide data predicted for Majuro Atoll were sufficiently accurate for this study. The location, characteristics and general condition of the shoreline structures (e.g. revetments, seawalls, and piers) were noted.

1.2.5 Climatic and oceanographic parameters and ASLR impacts

Shoreline inundation limits and shore protection design parameters were determined for the Study Areas using climatic, oceanographic and topographic data available for Majuro Atoll, and the profiles obtained during field studies. Parameters determined include wave heights, water levels and runup elevations for estimated 2-year, 50-year and typhoon events for present day sea level and two ASLR scenarios.

1.2.6 Alternative shore protection measures

General methods and techniques for shore protection, erosion control and shoreline flood protection were evaluated, including advantages and disadvantages, design and construction requirements, level of protection, construction material considerations and applicability to the Study Area.

1.2.7 Ecological investigations

Description and assessment on the existing terrestrial, shoreline and nearshore resources and environmental conditions was based on the Majuro Coastal Resources Atlas (Manoa Mapworks, 1989), the coastal resource inventory which was undertaken as a basis for the atlas (Maragos, et al, 1990; available in draft form only) and the Marshall Islands State of the Environment report (RMI, 1992). Additional, more detailed information was gathered through field investigations in each of the Study Areas. This included shoreline surveys and rapid ecological inventories of nearshore reef areas.

1.2.8 Socio-economic investigations

Socio-economic portions of the Case Study were based on statistics published by the Office of Planning and Statistics in the first and second Five Year Development Plans (OPS, 1986; OPS, 1991c), Statistical Abstracts 1988/89 and 1989/90 (OPS, 1989a; OPS, 1991a) and the National Population Policy (OPS, 1991b). This information provided the basis for a description of the social and economic situation, the projection of a development scenario and the analysis of potential social and economic impacts of ASLR and the response strategies.

1.3 Principal Findings

The principal findings of this Case Study have been summarised in the Executive Summary document which is available from the South Pacific Regional Environment Programme, the Marshall Islands Environmental Protection Agency or NOAA.

II. Delineation of Study Area and Specification of ASLR Scenarios

2.1 Boundaries Of Case Study Area

2.1.1 Study area location

The Marshall Islands consist of 34 atolls and islands. These total about 70 square miles (110 sq km) and are divided into two chains located in the West Central Pacific Ocean (Figure II-1). The atolls and islands enclose about 4,037 square miles (6511 sq km) of lagoon area. The country's EEZ encompasses about 750,000 square miles (1.2 million sq km) of ocean. This Case Study focuses on Majuro Atoll, the capital island of the Republic of the Marshall Islands, which is at latitude 7°N and longitude 171°E , near the southern end of the Ratak (eastern) chain of the Marshall Islands (Figure II-2).

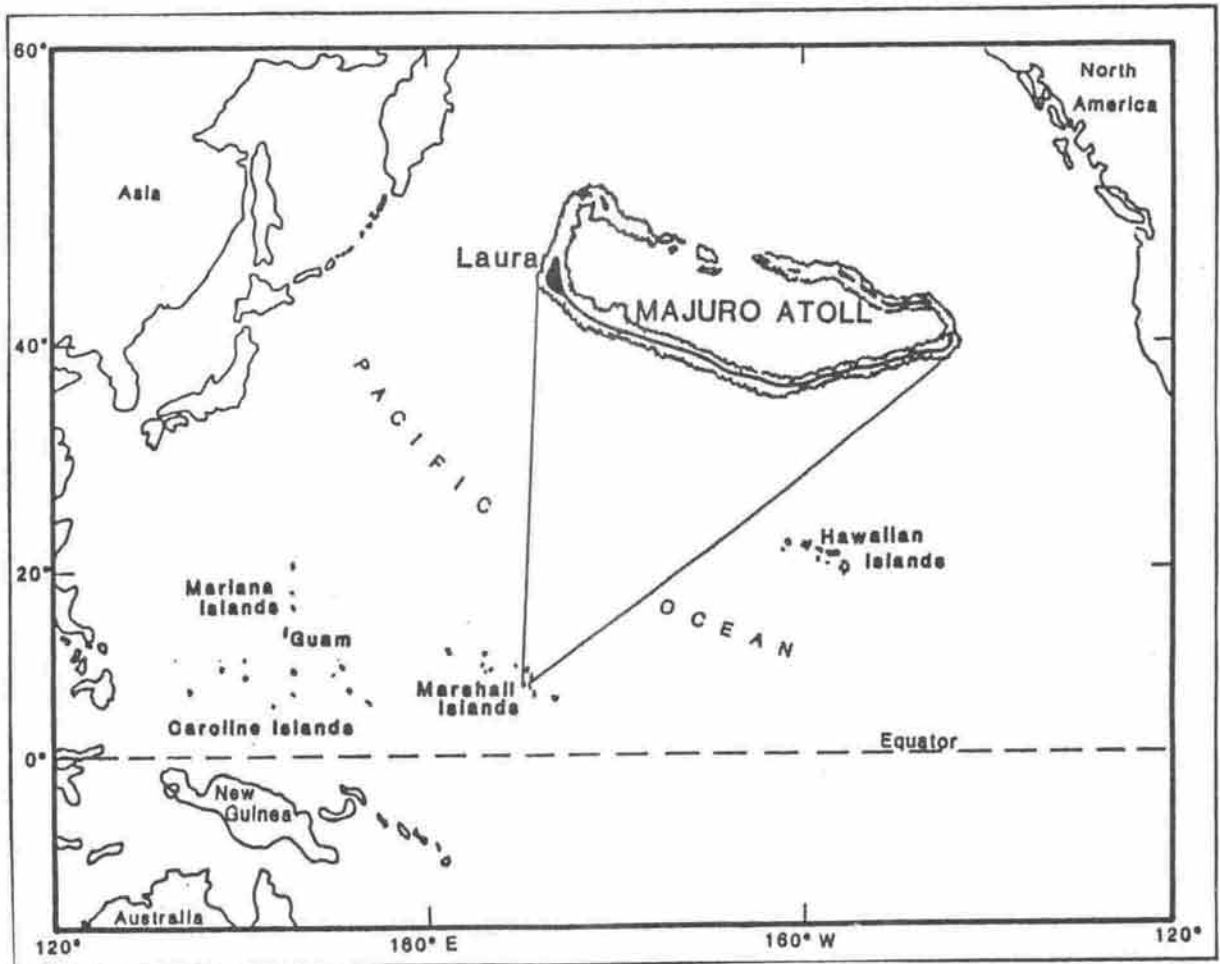

Figure II-1: Marshall Islands location map.

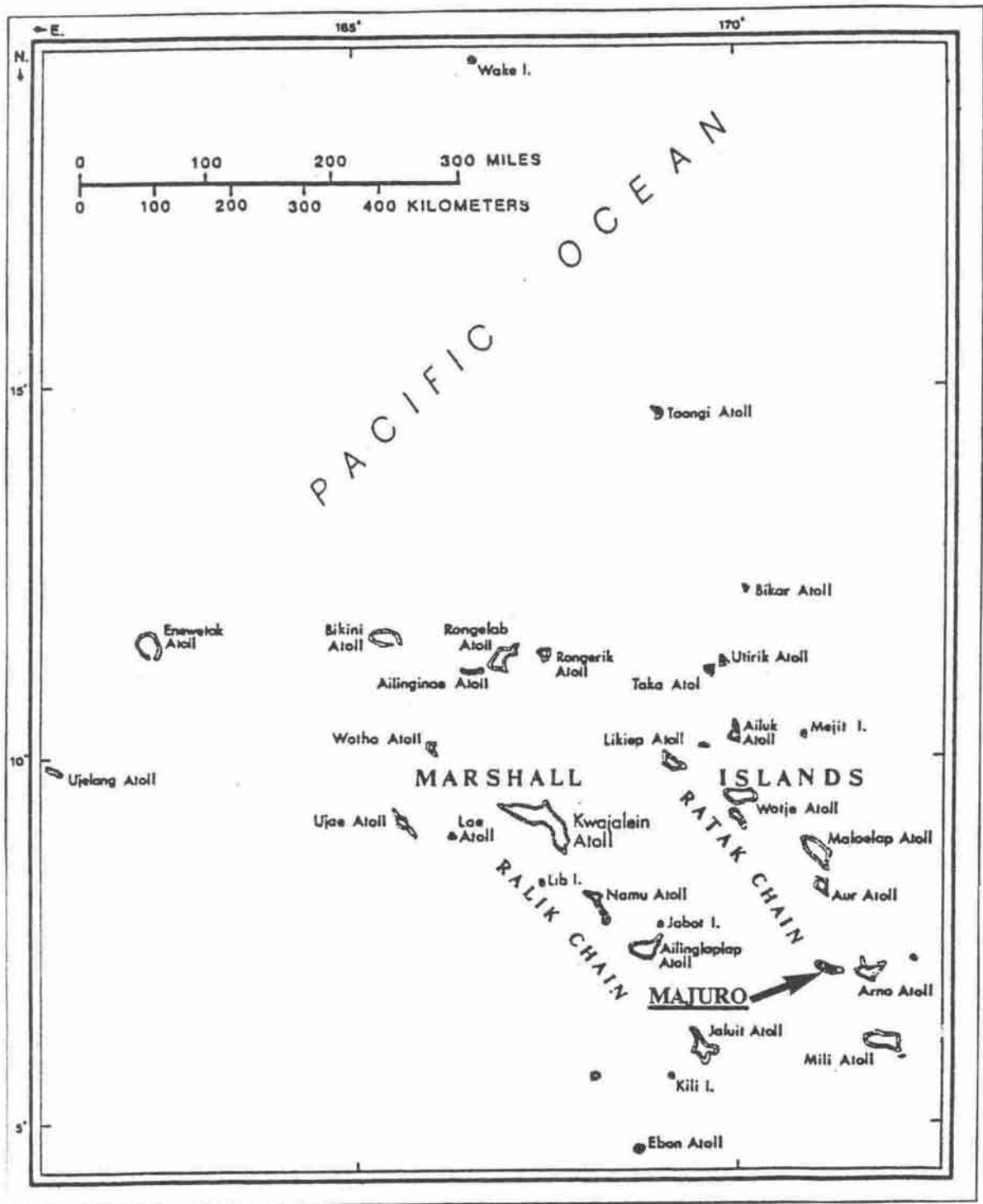

Figure II-2: Majuro Atoll location map.

Majuro Atoll is a typical atoll composed of a ring of reefs and 64 low islets enclosing a salt-water lagoon. The atoll is elongate in shape, extending 25 miles from east to west and 6 miles from north to south (Figure II-3). The land portion of the atoll varies in width from about 0.1 miles to more than 0.5 miles. The land area is about 4 square miles and the average land elevation is less than 8 feet. The lagoon has a surface area of about 125 square miles and an average depth of about 150 feet, descending to a maximum depth of 220 feet.

The major deep passes into Majuro Lagoon occur along a seven mile stretch of the NE side of the atoll. Most of the land is distributed along the southern and western sides. The islets of the eastern end of Majuro have been joined by causeways to make a single land mass.

2.1.2 Study Areas

Due to the large size of Majuro Atoll, four Study Areas were selected to represent the atoll (Figures II-3 and II-4). These are representative of typical portions of many atolls of the central Pacific.

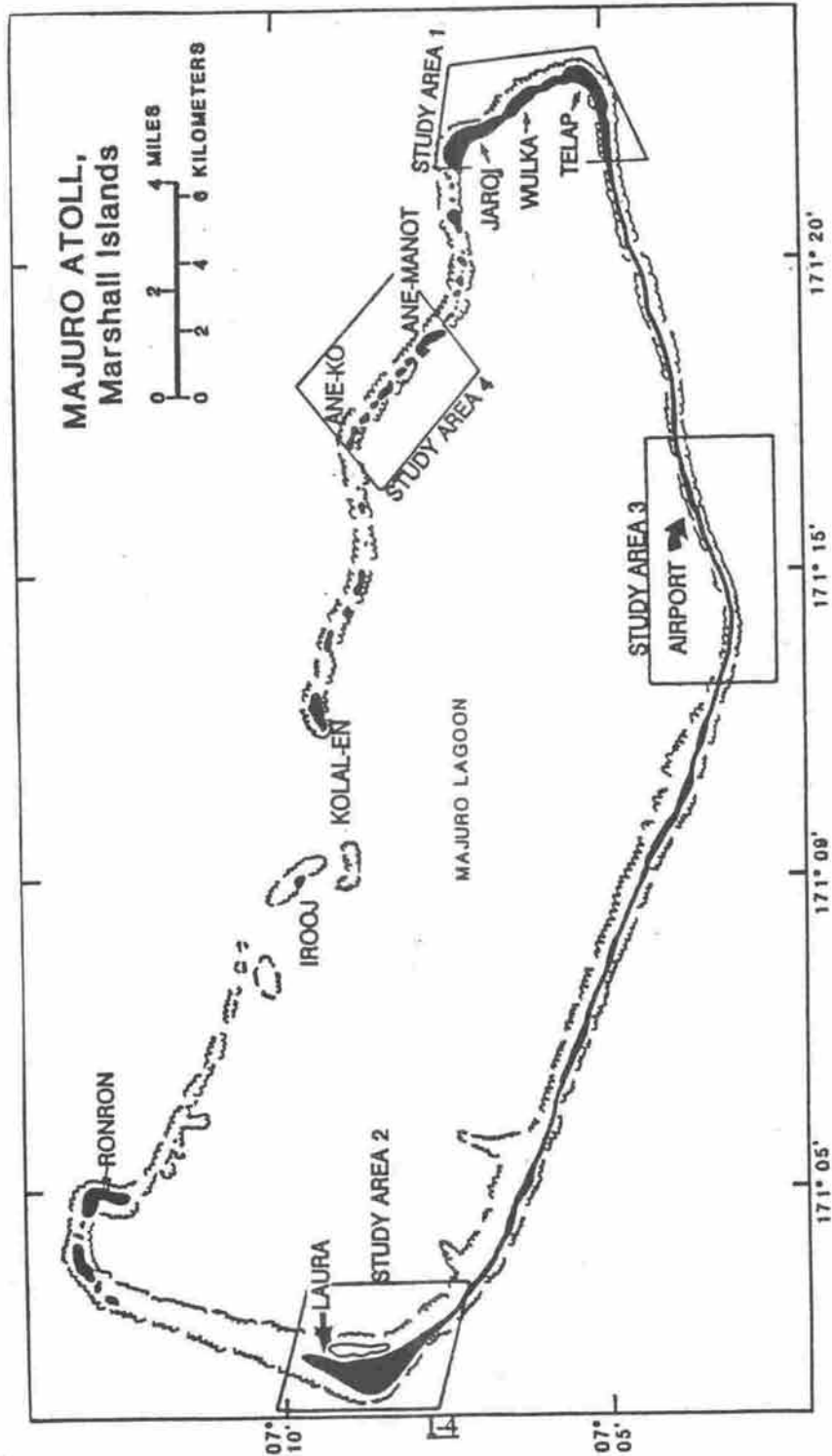

Figure II-3: Majuro Atoll and study area location map.

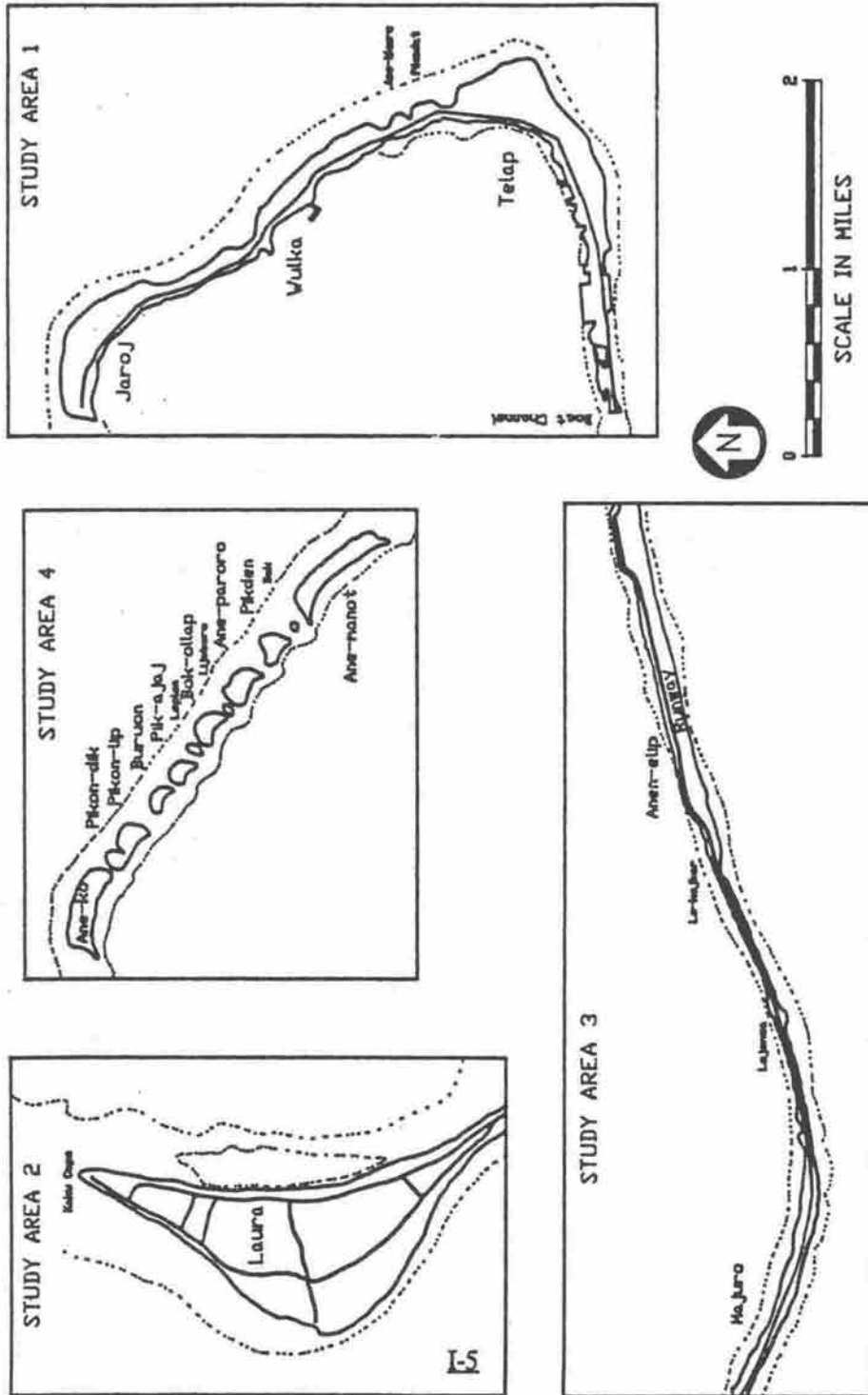

Figure II-4: Study area maps.

For each of the Study Areas, there was no inland boundary due to the low-lying and narrow characteristics of the land. The seaward boundary was the bottom of the ocean reef slope and the waters immediately surrounding the atoll, to an arbitrary distance offshore of 100 m. The lagoonward boundary was the bottom of the lagoon side reef slope, where it reaches average lagoon depths, and the overlying waters.

No separate "impact zones", as defined and called for in the Common Methodology, were designated due to the overwhelmingly narrow, low-lying nature of the land areas. However, the results of the Case Study reveal different areas of impact due to likely loss of land and flooding.

2.1.3 Study Area Characteristics

The general physical characteristics of each of the Study Areas are listed in Table II-1.

Table II-1: Study area characteristics.

Characteristics	Area 1	Area 2	Area 3	Area 4
Land area (sq mi)	0.8	1.2	0.4	0.2
(acres)	510	770	255	130
Land length (mi)	4.71	2.3	5.0	2.6
Shoreline length				
- Lagoon (mi)	4.8	2.5	5.0	2.5
- Ocean (mi)	5.6	3.3	5.0	3.8
Land width (ft)				
- minimum	330	660	165	165
- maximum	1980	4290	825	660
Reef flat area				
(sq mi)	0.8	1.2	0.5	0.7
(acres)	510	770	320	450
Reef flat width				
- Lagoon				
- minimum	10	990	165	165
- maximum	660	1980	330	825
- Ocean				
- minimum	65	330	165	330
- maximum	825	2310	660	660

○ Study Area 1 (Figure II-5 and II-6)

The Jaroj-Wulka-Telap area, at the east end of the atoll, is also commonly known as Dalap-Uliga-Darrit or just D-U-D. It is the commercial and population center of Majuro Atoll. Most of the facilities and the principal settlement are in this area. Of 19,600 people living on Majuro, about 14,600 people live in this area.

The area was chosen to represent the urban atoll setting with high density of human habitation. These atoll areas have major infrastructure development, significant shoreline alteration, largely degraded land and reef resources and are the location of government, commerce, transport and telecommunications.

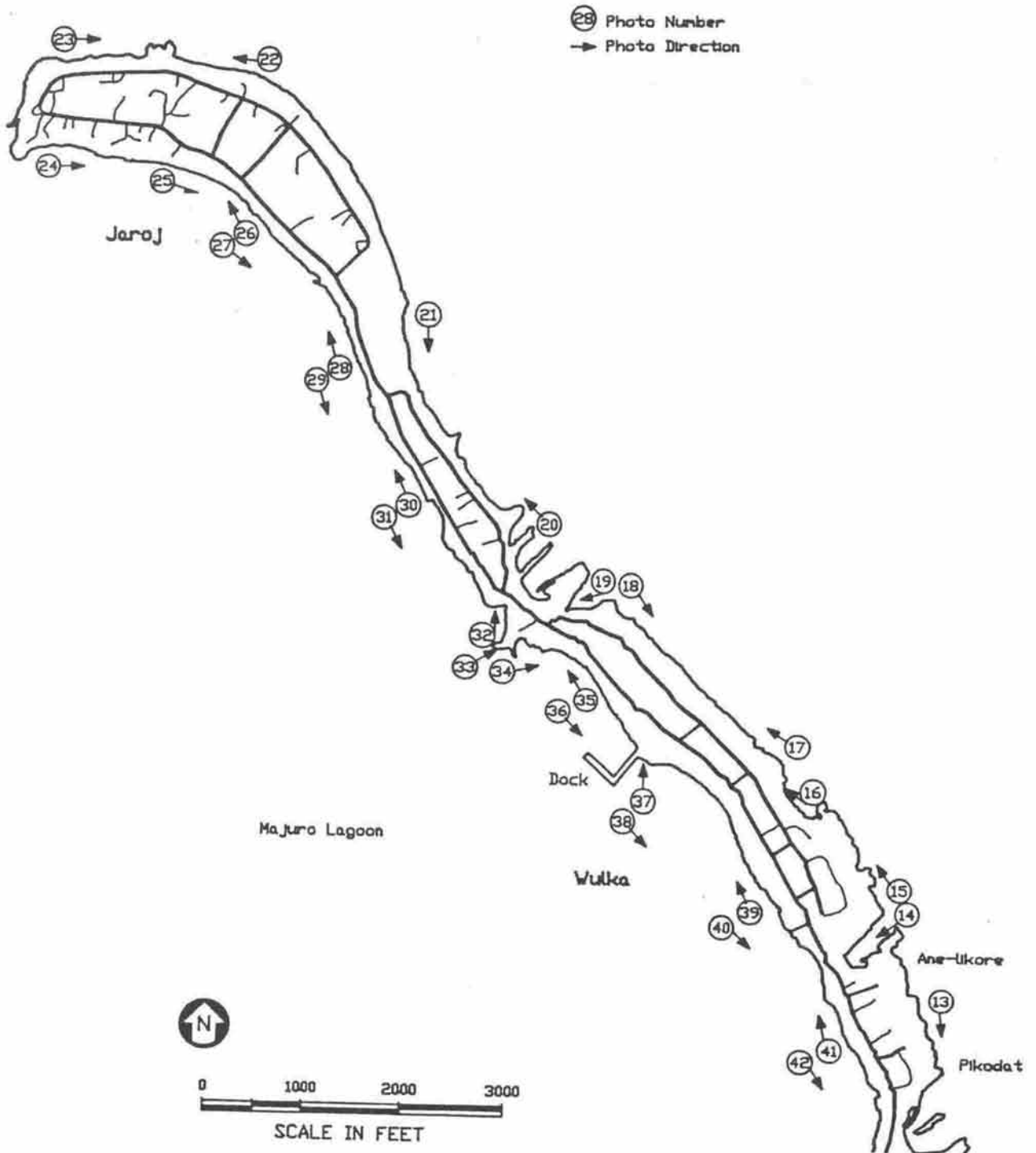
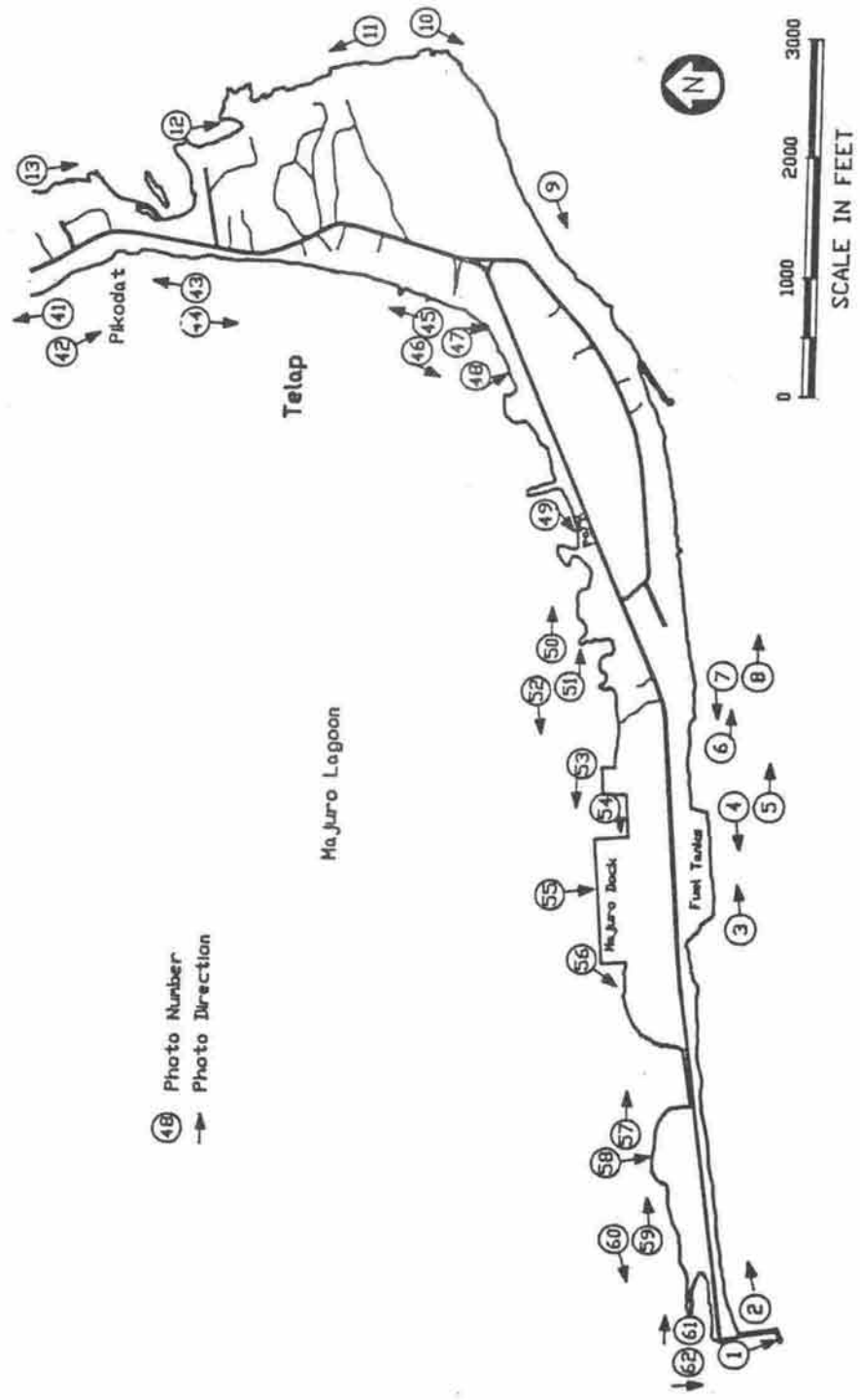

Figure II-5: Study area 1 map.



○ Photo Number
 → Photo Direction

Figure II-6: Study area 1 map.

○ Study Area 2 (Figure II-7)

This area, known as Laura, is the largest land mass of Majuro Atoll and contains important ground water resources. The land area is about equal to Study Area 1 but only less than 2,000 people live on Laura.

This area was chosen to represent the larger land mass portion of outer island atolls, which are basically rural in nature and make up the vast majority of the atoll land areas of the Pacific. These areas have little infrastructure development or shoreline alteration, low population density and terrestrial and marine habitats which are not significantly degraded. They often have important groundwater and agricultural resources.

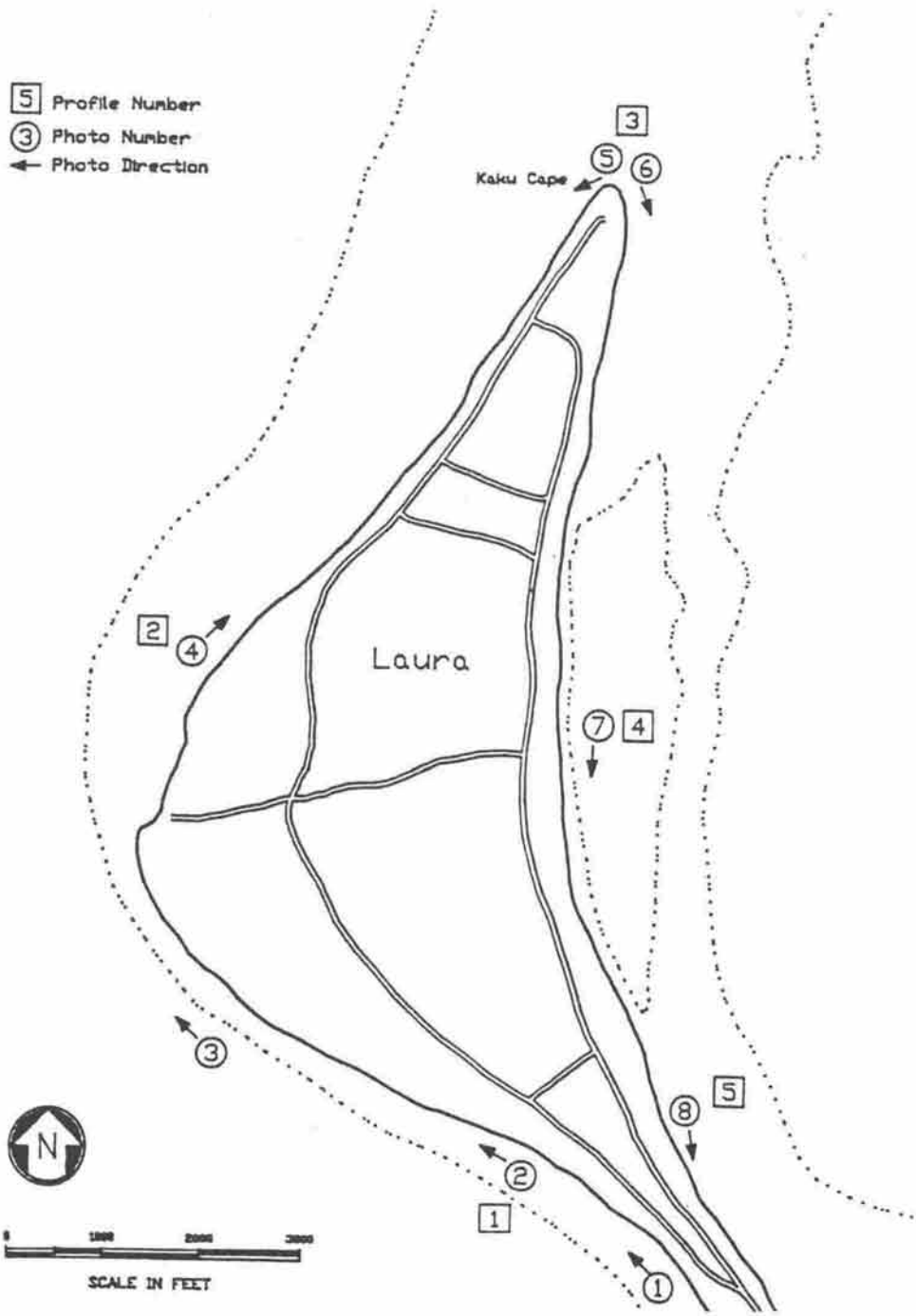

Figure II-7: Study area 2 map.

○ Study Area 3 (Figure II-8)

This area extends along the south side of Majuro Atoll, stretching between Laura and Dalap. The area is long and narrow, covering about 5 miles, a large portion of which consists of the airport and causeways connecting the islets.

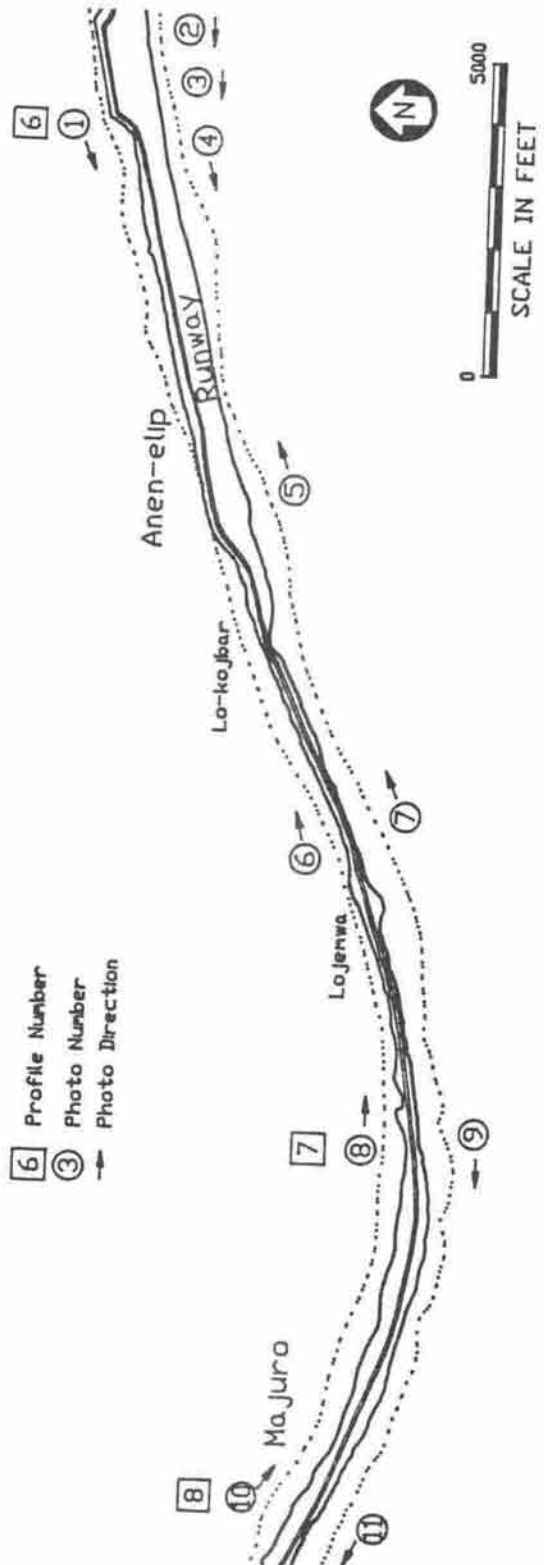

Figure II-8: Study area 3 map.

This area was chosen to represent the long and narrow land areas which are common on typical atolls. In addition, the area contains the airport, which is an essential part of modern atoll infrastructure, which is often constructed along these long narrow portions of atoll islets. Long causeways connecting islets are an increasingly common feature of atolls, especially urbanised capital atolls. These essentially create long narrow man-made land areas which will also be impacted by ASLR.

○ Study Area 4 (Figure II-4)

This area is the chain of islets from Ane-ko to Ane-manot, located at the NE end of Majuro Atoll. The area is about 3 miles long and contains about 10 small islets separated from each other by short distances on the reef flat which are generally awash at all but low tide.

This area was chosen to represent the many portions of atolls which consist of a series of small islets. These do not usually support very high numbers of permanent inhabitants, but serve as a base for the use of terrestrial and marine resources in the area. These areas, as with the long, narrow islets, have very high shoreline to land area ratios. The shoreline is generally unaltered and the marine environment not degraded in these outer islets.

2.2 Climate Factors

Existing climatic conditions and events, especially wind, storms and cyclones, result in oceanographic conditions which have a large influence on the potential effects of ASLR. In particular, wave and swell conditions resulting from climatic conditions and events are important in relation to water level and wave activity, wave runoff and inundation. In addition, tides and changes in atmospheric pressure have effects on sea level which must be considered when evaluating oceanographic conditions.

2.2.1 Rainfall and storms

Rainfall at Majuro Atoll is heavy, averaging about 140 inches annually. May to November are normally the wettest months, while December to April is dry. Temperatures are relatively constant throughout the year. Mean monthly temperatures range one degree (81° to 82°F) between the coolest and warmest months. Average daily temperatures range from the mid-seventies and mid-eighties. Relative humidity is high throughout the year, and slightly lower in the dry season.

Severe storms with damaging winds are infrequent near Majuro Atoll, although typhoons can occur in the vicinity. In 1918 a major storm resulted in the loss of many lives at a time when the population numbered only 1400. More recently, a severe storm damaged Majuro during January 6-8, 1992. The analyses and storm parameters presented in this report were completed in late 1991, and therefore do not include this storm. Data from the January storm, however, is discussed for comparative purposes in the relevant sections of the Case Study. In general, tropical disturbances tend to originate in the region and move from east to west.

2.2.2 Winds

The prevailing winds at Majuro Atoll are northeasterly tradewinds. They occur about 80 % of the time, and wind speeds average approximately 10 knots. The tradewinds predominate from December to April with moderate wind speeds, but they become weaker and are less steady in May to November.

Wind data for Majuro Atoll has been collected and published in two sources: (1) Summary of Synoptic Meteorological Observations (SSMO) - Area 8, by the U.S. Naval Weather Service Command; and (2) Local Climatological Data, prepared by the Majuro Weather Service for the U.S. Weather Bureau (NOAA, 1989a; NOAA, 1989b).

SSMO wind data are based upon open ocean observations of sea conditions reported by ships in transit through the area. Synoptic meteorological observations by ships at sea can be misleading, particularly concerning extreme events as: 1) the data typically lacks information on storm winds because ships consciously avoid bad weather and 2) there is a lack of uniformity of observation techniques among different crews. Nonetheless, SSMO data provides a good summary of prevailing wind conditions near Majuro Atoll. The annual percent frequency of wind speed and direction based on SSMO for a 33-year period of record (1938-1970) is shown in Table II-2.

Table II-2: Annual percent frequency of wind direction versus wind speed for Majuro Atoll. (SSMO Data 1938-1970)

Wind Dir	Wind Speed (knots)						Total (%)	Total (#)	MEAN SPD
	0-3	4-10	11-21	22-33	34-47	48+			
N	1.1	1.5	0.7	0.1	0.0	0.0	3.4	129	8.4
NE	2.4	13.0	19.4	1.3	0.0	0.0	36.1	1555	11.1
E	4.0	19.9	20.1	1.2	0.0	0.0	45.2	1759	10.8
SE	0.9	3.7	2.4	0.0	0.0	0.0	6.9	223	9.2
S	0.6	1.9	0.6	0.0	0.0	0.0	3.1	92	6.6
SW	0.3	0.8	0.2	0.0	0.0	0.0	1.3	35	4.7
W	0.6	0.9	0.1	0.0	0.0	0.0	1.5	45	3.7
NW	0.4	0.6	0.2	0.0	0.0	0.0	1.2	36	5.9
VAR	0.0	0.0	0.0	0.0	0.0	0.0	0.0	0	0.0
CALM	1.2						1.2	41	0.0
Total(%)	11.5	42.4	43.6	2.6	0.0	0.0	100.0		
Total(#)	386	1548	1859	125	0	0		3918	10.5

The data in Table II-2 can be statistically analyzed to determine the frequency of extreme wind speed as a function of return occurrence of a given event. Gumbel's first asymptotic distribution has been shown to provide a good fit for extreme wind and wave predictions, and was used to determine the predicted wind speed versus return period shown on Table II-3. For simplicity, the results in Table II-3 are determined without including wind direction and are independent of wind direction; equal probability of occurrence from any direction is assumed. The annual fastest mile wind speed and direction measured by the Majuro Weather Service is shown in Table II-3.

Table II-3: Annual maximum fastest mile wind speed (mph) at Majuro Atoll. (US Weather Bureau Data 1958-1990)

Year	Fastest Mile Wind Speed	Year	Fastest Mile Wind Speed	Year	Fastest Mile Wind Speed	Year	Fastest Mile Wind Speed
1958	34	1966	35	1974	34	1982	45
1959	36	1967	38	1975	34	1983	32
1960	34	1968	34	1976	32	1984	35
1961	36	1969	37	1977	30	1985	38
1962	38	1970	34	1978	37	1986	38
1963	35	1971	32	1979	34	1987	30
1964	38	1972	38	1980	30	1988	47
1965	33	1973	38	1981	34	1989	28
						1990	35

Because of the nature of Gumbel's analysis, an extreme wind for one-year return period cannot be determined. Instead, 2-year wind speed is considered as the annual extreme wind in this study. The annual extreme wind speed is, then, 34 miles per hour (mph) and the 50-year wind is 47 mph.

During the storm of January 6-8, 1992, peak wind speeds of 53 mph were recorded. A 2-hour power failure, however, during the height of the storm shut down the meteorological instrumentation. Peak wind speeds during this interval were estimated to be 60 mph. Winds during the storm, therefore were stronger than the computed 50 year wind event presented in Table II-4.

Table II-4: Predicted wind speed at Majuro Atoll as a function of return period. (based on US Weather Bureau Data)

Return Period (years)	Fastest-Mile Wind Speed (mph)
2	34
10	37
25	45
50	47

2.2.3 Waves

Majuro Atoll is exposed to sea and swell generated from nearly all directions. The primary wave types affecting the atoll are:

- the prevailing easterly tradewind waves,
- south and north Pacific swell, and
- waves generated by tropical storms and typhoons.

Tradewind waves may be present throughout the year and are highest from December through April. They result from the steady tradewinds blowing from the east-northeast over open ocean. Typically, the deep water tradewind waves have periods of 5 to 8 seconds and heights of less than 6 feet.

South Pacific swell is generated during the southern hemisphere winter and is most prevalent during the months of April through October. North Pacific swell is produced by severe storms in the Aleutian area of the North Pacific Ocean and by mid-latitude low pressure systems. North swell may occur throughout the year but is largest and most frequent during the northern winter months of October through March. South swell is generally characterized by long, low waves approaching from the southeast through southwest, with periods of 12 to 20 seconds and deepwater wave heights of 2 to 6 feet. North Pacific swell typically has periods of 10 to 16 seconds and heights of 5 to 15 feet.

No quantitative data is available regarding the characteristics and frequency of south and north Pacific swell in Majuro. It is reasonable, however, to assume that the characteristics of these waves are similar to those that reach Hawaii. These long-period ocean swells have the potential to do considerable damage to a low-lying atoll such as Majuro because of their potential for wave runup and overtopping of the land area. This does not often occur, suggesting that severe north and south swells do not occur frequently.

SSMO provides some wave height and period information for Majuro, as shown in Table II-5. Although SSMO data may lack information on longer periods and larger wave heights, this is the only observed wave data available for Majuro and is used in this study to approximate wave conditions for a given return period. These approximations using Gumbel's analysis are presented in Table II-6. The 2-year wave is 13 feet high and the 50-year wave is 19 feet high. The period for these waves is considered to be 13 seconds since high waves in Table II-5 are accompanied by wave periods ranging between 12 and 13 seconds.

Table II-5: Annual percent frequency of wave height versus period for Majuro Atoll. (SSMO Data, 1963-1970)

Height (feet)	Wave Period (seconds)						Indet.	Total (%)	Total (#)
	<6	6-7	8-9	10-11	12-13	>13			
<1	3.6	0.0	0.0	0.0	0.0	0.0	2.2	5.8	31
1-2	12.4	1.6	0.5	0.0	0.0	0.0	0.2	14.7	86
3-4	13.1	11.9	3.9	0.0	0.8	0.0	0.6	30.3	161
5-6	9.3	13.1	3.5	2.5	0.1	0.2	1.0	29.8	157
7	2.0	4.3	2.4	0.6	0.0	0.1	0.1	9.6	52
8-9	0.3	4.0	1.1	0.4	0.4	0.0	0.0	6.2	31
10-11	0.1	1.6	0.5	0.0	0.2	0.0	0.0	2.4	12
12	0.0	0.5	0.0	0.0	0.0	0.0	0.0	0.5	2
13-16	0.0	0.2	0.0	0.0	0.5	0.0	0.0	0.7	4
>17	0.0	0.0	0.0	0.0	0.0	0.0	0.0	0.0	0
Total(%)	42.9	35.3	11.6	3.7	1.7	0.4	4.5	100.0	
Total(#)	230	189	62	20	9	2	24		536

Table II-6: Predicted significant wave height for Majuro Atoll as a function of return period (based on SSMO Data, 1963-1970)

Significant Return Period (years)	Wave Height (feet)
2	13
10	16
25	17
50	19

2.2.4 Atmospheric pressure

Changes in atmospheric pressure over the sea cause water level changes. Table II-7 gives SSMO seasonal atmospheric pressure data near Majuro Atoll during a period of 26 years (1945-1970). Although SSMO data lacks information for severe weather conditions, the pressure data are used to approximate sea level fluctuations due to the pressure changes.

Table II-7: Seasonal atmospheric pressure (mbs) by percentiles for Majuro Atoll. (SSMO Data 1945-1970)

Month	Percentiles							Total (#)
	1%	5%	25%	50%	75%	95%	99%	
Jan.	1003	1005	1007	1009	1010	1011	1012	308
Feb.	1005	1006	1008	1010	1011	1013	1014	387
Mar.	1006	1007	1009	1010	1011	1013	1014	337
Apr	1007	1007	1009	1010	1012	1013	1014	237
May	1007	1008	1009	1010	1011	1012	1013	387
Jun	1005	1006	1009	1011	1012	1014	1014	383
Jul	1006	1006	1008	1009	1011	1013	1014	227
Aug	1006	1006	1008	1009	1011	1014	1014	151
Sep	1002	1002	1006	1009	1011	1013	1014	158
Oct	1004	1004	1007	1009	1010	1012	1012	128
Nov	1003	1005	1008	1009	1010	1012	1012	226
Dec	1005	1006	1007	1009	1010	1012	1014	141
Total(#)								3070

A regression analysis was used to determine minimum atmospheric pressures for a given return period and the results are presented in Table II-8. The predicted annual minimum atmospheric pressure is 1004 millibars (mbs) and the 50-year pressure is 1001 mbs. The lowest pressure recorded during the January 1992 storm was 998.8 mbs. This pressure is lower than the computed 50 year pressure event.

Table II-8: Predicted atmospheric pressure for Majuro Atoll as a function of return period. (Based on SSMO Data)

Return Period (years)	Water Surface Air Pressure (mbs)
2	1004
10	1003
25	1002
50	1001

2.2.5 Tropical cyclones

The Annual Tropical Cyclone Reports, published by the Joint Typhoon Warning Center, show that tropical cyclones near the Marshall Islands are generally in their formation stage. They rarely reach typhoon strength until they have moved well west of the Marshall Islands. According to wind data recorded at Majuro Atoll (see Table II-3) and at Kwajalein Atoll, no storm with typhoon strength has hit either atoll for over 30 years. Kwajalein Atoll is a member of the Marshall Islands and is located about 220 nautical miles northwest of Majuro Atoll (see Figure II-2).

The history of tropical cyclones passing through the Marshall Islands was examined. Table II-9 shows tropical storms and typhoons that have passed within 150 nautical miles of Majuro Atoll and Kwajalein Atoll during a 15-year period from 1974 to 1988. Only two tropical storms and no typhoon approached Majuro within 150 nautical miles during the 15-year period. A tropical storm did hit Majuro from January 6-8, 1992. Four tropical storms and two typhoons passed within 150 nautical miles of Kwajalein during the same period. According to Table II-9, Majuro Atoll is less exposed to storms than Kwajalein Atoll.

The maximum fastest mile wind speed recorded at Majuro from 1958 to 1990 was 47 mph or 41 knots. The wind speed threshold for a typhoon is 64 knots, thus the worst recorded wind condition at Majuro in the past 34 years are well below typhoon strength. The peak winds at Majuro during the January 1992 storm were estimated between 55-60 mph (48-52 knots). However, two typhoons have approached Kwajalein between 1977 and 1982. Projections that global atmospheric warming will change storm intensities, frequencies and patterns make it reasonable to consider that there is a potential typhoon threat at Majuro Atoll. Based on storms in Table II-9, a scenario typhoon is defined with following parameters:

The maximum sustain wind speed (U_R)	=	75 knots
Forward speed of the typhoon (V_F)	=	12 knots
Radius to maximum wind (R)	=	15 n.m.
Central pressure of typhoon (P)	=	964 mbs
Central pressure reduction (P)	=	49 mbs or 1.5 inches of mercury.

The radius of maximum wind, R, was estimated by taking 60 percent of the average historical eye diameter.

2.2.6 Currents

The general currents through the Marshall Islands are dominated by the west setting Northern Equatorial Current in the north part of the group. In the south part they are dominated by the east setting Equatorial Counter Current. Majuro Atoll is situated near the southern boundary of the North Equatorial Current, causing local westward currents with speeds of 0.5 to 1.5 knots. When the Equatorial Counter Current shifts northward, local currents may head temporarily eastward.

A general description of currents in and around the atoll is given in the Sailing Directions for the Pacific Islands (Defense Mapping Agency, 1976). The currents off the north and south sides of the atoll set to the west, and at the east and west end they set to the south. In the lagoon currents flow consistently westward with speeds less than 1/2 knot. In Calal-en Channel, the rate for both flood and ebb is about 1 knot. The currents turn about the time of high and low water. Just within the entrance, the maximum flood current sets in a south-southwest direction at a rate of 1/2 knot and maximum ebb sets west-northwestward at a rate of 1/2 knot.

Current measurements in the lagoon were reported by Rosti (1989). The results show that currents generally flow westward despite the tide stages. In the east end of the lagoon along the D-U-D shore, ebb and flood tidal currents head southwestward with an average speed of 0.2 knot. In the west end of the lagoon, the average flows measured during ebb tide are very slow with a speed of 0.1 knot. Local sources, however, suggest that the flow is strongly northwestward during rising tide and high tide. Near the airport and elsewhere along the southern shore, ebb currents average 0.2 knots westward. Along the north side of the lagoon, near Ane-manot Island, water enters the lagoon from the north between islets at high tide. The measured currents are also westward. In the Calalen Channel area, currents move in the lagoon in a generally southwesterly direction on a rising tide. The flows are slightly greater than 1/2-knot.

Table II-9: Tropical storms and typhoons within 150 N.M. of Majuro Atoll and Kwajalein Atoll. (Annual Typhoon Reports, 1974-1988)

Name	Date	CPA	T _B	V _F	T _F	P	U _{max}	ED
Majuro Atoll:								
Roy	1/88	100	NW	10	West	-	40	-
Pamela	11/82	0	-	11	West	-	50	-
Kwajalein Atoll:								
Roy	1/88	0	South	-	West	-	-	-
Pamela	11/82	18	South	15	West	967	75	25
Freda	3/81	130	South	10	NW	993	40	-
Alice	1/79	40	East	8	North	982	56	35
Rita	10/78	130	North	14	West	968	60	10
Mary	12/77	100	North	14	West	964	65	30

- Notes:
- CPA - Closest point of approach to Majuro or Kwajalein (in n.m.)
 - T_B - Bearing of the cyclone center off the atoll
 - V_F - Forward speed of the cyclone in knots within 150 n.m. of the atoll
 - T_F - Direction toward which the cyclone moves at CPA
 - P - The central pressure of the cyclone in mbs within 150 n.m. of the atoll
 - U_{max} - The maximum wind speed of the cyclone in knots within 150 n.m. of the atoll
 - ED - Eye diameter in n.m. within 150 n.m. of the atoll

2.2.7 Tides

The tides at Majuro Atoll are semi-diurnal, with pronounced diurnal inequalities (i.e., two tidal cycles per day of unequal tidal range). Annual tide predictions are published by the U.S. Department of Commerce. Predicted mean range and mean spring range at Majuro Atoll are 3.7 feet and 5.3 feet. A highest tidal level observed at Majuro in 1977 was 6.8 feet above the datum or 3.6 above mean sea level (MSL), reported by Dames and Moore (1979). The datum is one-half foot below Mean Low Water Spring. Tidal elevations based on the predicted tidal ranges for Majuro Atoll are as follows:

- Highest Tide Predicted for 1992 : 3.5 feet above MSL
- Highest Tide Observed During 1977 : 3.6
- Mean High Water Spring : 2.6
- Mean High Water : 1.9
- Mean Tide (MSL) : 0.0
- Mean Low Water : -1.8
- Mean Low Water Spring : -2.7
- Lowest Tide Predicted for 1992 : -3.2
- Datum: -3.2

In this study we assume that the tidal ranges are uniform throughout the atoll.

2.3 Specification Of ASLR Scenarios

2.3.1 Accelerated Sea Level Rise

In this Case Study, the Accelerated Sea Level Rise of 1.0 meter by the year 2100 is adopted to assess worst case impact to shoreline communities. Three scenario cases of future sea level rises are considered: (1) no sea level rise, (2) ASLR=1 = 0.3 meter (1.0 foot) rise, (3) ASLR=3.3 = 1.0 meter (3.3 feet) rise as specified by the Common Methodology (IPCC, 1991).

Under any of these scenarios, it is the rise in the level of the water and the action of waves which will create the impacts. Thus it is critical to establish design wave heights and stillwater rise as a basis for determining wave runup and inundation limits, i.e. the area where impacts will occur.

2.3.2 Design waves

Majuro Atoll is subject to waves generated by tropical storms or typhoons passing through the Marshall Islands, but not necessarily passing directly over the atoll. The average annual fastest-mile wind speed based on the data in Table II-3 is 35 mph, which is less than the 39 mph threshold for tropical storms. Waves generated by strong winds in these nearby storms are considered to represent wave design conditions with a probable chance of occurrence in Majuro. The potential for a typhoon to directly strike Majuro is low, and represents worst case design wave conditions.

Three waves conditions are analyzed in this study to aid in assessing the existing shoreline vulnerability and evaluate the need for shore protection improvements:

- 2-year Event - representing annual conditions
- 50-year Event - representing probable extreme conditions
- Typhoon Event - representing worst case conditions

For comparison, the January 1992 storm was more severe than the 50-year event, but significantly less severe than the typhoon event.

The actual probability of any of the three cases directly striking any specific site of the Study Areas is likely less than is indicated by the estimated return periods for each case, due to the variability in directions of winds and waves. Thus, the analysis and results are conservative. The results, however, represent reasonable general planning and design guidelines for assessing shore protection problems and needs in the Study Area.

The details for calculating design waves for the three events are given in Annex I. The wave conditions for the 2-year, 50-year and typhoon event are given in Table II-10.

Global atmospheric warming could conceivably affect the waves at Majuro Atoll, since it may change wind and storm patterns. Information on these effects is not available, and wave prediction is based on historical data.

2.3.3 Stillwater level rise

An important step in determining storm inundation limits and wave runup elevations is estimating stillwater level rise. Runup elevations are added to stillwater level rise.

Table II-10: Deepwater design wave heights (H_s , feet) and periods (T, secs)

	Fetch(n.m)/ Depth (ft)	Annual Wave		50-year Wave		Typhoon Wave	
		H_s	T	H_s	T	H_s	T
Ocean Side							
All Study Areas	N/A	13	13	19	13	27	11
Lagoon Side							
Study Area 1 & 2	21/140	6	5	8	6	19	8
3 & 4	6/140	3	4	4	4	11	5

The rise in stillwater level along the shoreline during extreme wind and wave events is generally a function of three components: (1) the astronomical tide, (2) storm surge due to reduced atmospheric pressure and wind stress setup, and (3) wave setup.

These water level rise conditions are analyzed for three design conditions as defined in the preceding section:

- 2-year Event - representing annual conditions
- 50-year Event - representing probable extreme conditions
- Typhoon Event - representing worst case conditions.

The stillwater level rise caused by tides, storm surge and wave setup are considered in conjunction with the ASLR scenarios. The scenarios for calculating stillwater level rise are presented in Annex 2. The results are shown in Tables II-11 to II-16.

Table II-11: Ocean side stillwater level rise for ASLR=0 (in feet above MSL)

	Annual Extreme	50-Year Extreme	Typhoon Event
ASLR	0.0	0.0	0.0
Astronomical Tide	2.6	2.6	2.6
Pressure Setup	0.3	0.4	1.7
Wind Setup	0.0	0.0	0.0
Subtotal	2.9	3.0	4.3
Wave Setup:			
Study Area 1	2.0	3.0	4.0
Study Area 2	2.0	3.0	4.0
Study Area 3	2.0	3.0	4.0
Runway section	1.5	2.5	3.5
Study Area 4	1.0	1.5	2.0
Total:			
Study Area 1	4.9	6.0	8.3
Study Area 2	4.9	6.0	8.3
Study Area 3	4.9	6.0	8.3
Runway section	4.4	5.5	7.8
Study Area 4	3.9	4.5	6.3

Table II-12: Ocean side stillwater level rise : ASLR=1 (in feet above MSL)

	Annual Extreme	50-Year Extreme	Typhoon Event
ASLR	1.0	1.0	1.0
Astronomical Tide	2.6	2.6	2.6
Pressure Setup	0.3	0.4	1.7
Wind Setup	0.0	0.0	0.0
Subtotal	3.9	4.0	5.3
Wave Setup:			
Study Area 1	1.8	3.0	4.0
Study Area 2	1.8	3.0	4.0
Study Area 3	1.8	3.0	4.0
Runway section	1.4	2.4	3.3
Study Area 4	1.0	1.3	1.6
Total:			
Study Area 1	5.7	7.0	9.3
Study Area 2	5.7	7.0	9.3
Study Area 3	5.7	7.0	9.3
Runway section	5.3	6.4	8.6
Study Area 4	4.9	5.3	6.9

Table II-13: Ocean side stillwater level rise for ASLR=3.3 (in feet above MSL)

	Annual Extreme	50-Year Extreme	Typhoon Event
ASLR	3.3	3.3	3.3
Astronomical Tide	2.6	2.6	2.6
Pressure Setup	0.3	0.4	1.7
Wind Setup	0.0	0.0	0.0
Subtotal	6.2	6.3	7.6
Wave Setup:			
Study Area 1	1.6	2.7	3.7
Study Area 2	1.6	2.7	3.7
Study Area 3	1.6	2.7	3.7
Runway section	1.1	2.0	2.8
Study Area 4	0.6	1.0	1.4
Total:			
Study Area 1	7.8	9.0	11.3
Study Area 2	7.8	9.0	11.3
Study Area 3	7.8	9.0	11.3
Runway section	7.3	8.3	10.4
Study Area 4	6.8	7.3	9.0

Table II-14: Lagoon side stillwater level rise for ASLR=0 (in feet above MSL)

	Annual Extreme	50-Year Extreme	Typhoon Event
ASLR	0.0	0.0	0.0
Astronomical Tide	2.6	2.6	2.6
Pressure Setup	0.3	0.4	1.7
Wind Setup	0.0	0.0	0.0
Subtotal	2.9	3.0	4.3
Wind Setup:			
Study Area 1	0.2	0.3	1.4
Study Area 2	0.2	0.3	1.4
Study Area 3	0.0	0.1	0.4
Study Area 4	0.0	0.0	0.0
Wave Setup:			
Study Area 1	0.5	0.8	2.0
Study Area 2	0.5	0.8	2.0
Study Area 3	0.1	0.2	1.0
Study Area 4	0.0	0.0	0.6
Total:			
Study Area 1	3.6	4.1	7.7
Study Area 2	3.6	4.1	7.7
Study Area 3	3.0	3.3	5.7
Study Area 4	2.9	3.0	4.9

Table II-15: Lagoon side stillwater level rise for ASLR=1 (in feet above MSL)

	Annual Extreme	50-Year Extreme	Typhoon Event
ASLR	1.0	1.0	1.0
Astronomical Tide	2.6	2.6	2.6
Pressure Setup	0.3	0.4	1.7
Wind Setup	0.0	0.0	0.0
Subtotal	3.9	4.0	5.3
Wind Setup:			
Study Area 1	0.2	0.3	1.4
Study Area 2	0.2	0.3	1.4
Study Area 3	0.0	0.1	0.4
Study Area 4	0.0	0.0	0.0
Wave Setup:			
Study Area 1	0.4	0.7	1.9
Study Area 2	0.5	0.8	1.9
Study Area 3	0.1	0.2	1.0
Study Area 4	0.0	0.0	0.6
Total:			
Study Area 1	4.5	5.0	8.6
Study Area 2	4.6	5.1	8.6
Study Area 3	4.0	4.3	6.6
Study Area 4	3.9	4.0	5.7

Table II-16: Lagoon side stillwater level rise for ASLR=3.3 (in feet above MSL)

	Annual Extreme	50-Year Extreme	Typhoon Event
ASLR	3.3	3.3	3.3
Astronomical Tide	2.6	2.6	2.6
Pressure Setup	0.3	0.4	1.7
Subtotal	6.2	6.3	7.6
Wind Setup:			
Study Area 1	0.2	0.3	1.4
Study Area 2	0.2	0.3	1.4
Study Area 3	0.0	0.1	0.4
Study Area 4	0.0	0.0	0.0
Wave Setup:			
Study Area 1	0.1	0.5	1.6
Study Area 2	0.3	0.6	1.8
Study Area 3	0.0	0.0	0.6
Study Area 4	0.0	0.0	0.3
Total:			
Study Area 1	6.5	7.1	10.6
Study Area 2	6.7	7.2	10.8
Study Area 3	6.2	6.4	8.6
Study Area 4	6.2	6.3	7.9

III. Inventory of Study Area

Characteristics

3.1 Characteristics Of Natural Systems

3.1.1 *Marshall Islands*

Much of this information is summarised from the State of the Environment Report (RMI, 1992), which contain references for the source of information presented in this section, and Maragos, et al (1990).

○ Geomorphology

The Marshalls Islands consist of a series of mid-ocean reef platforms rising from ocean depths of over 5,000 feet (1525 m), which form atolls and reef islands. Atolls are ring shaped reef features enclosing a central lagoon, with a series of low-lying islets positioned around the ring reef. Lagoon depths in the Marshall Islands average about 150 feet (45 m). Reef islands are low-lying islets positioned on a reef platform, without a central depression or lagoon. In all cases, the land area is built of reef-derived sediments (coral and calcareous algae debris, foraminifera, molluscs) deposited onto the shallow reef platform.

The land is generally flat, rarely reaching over 10 feet (3 m) in elevation. The beach berms (ridges) composed of storm- deposited reef materials form the highest point in the land mass. Soils are very poor and consist of calcareous sediment, with limited organic input from the island vegetation. The soil is very porous with high salinity due to salt spray and high evaporation rates. Larger land areas support a lens of fresh water, which floats on, and mixes with, the denser sea water permeating the carbonate sediments and structure below the islet. The lens depends on recharge by rainwater, as there is no surface runoff on the porous land mass, and is affected by the size and shape of the island and tidal fluctuations.

○ Terrestrial flora

Most of the original vegetation of the Marshall Islands has been replaced by coconut plantations, although atoll plant communities are relatively poor in any case. Small stands of native forest remain on some islands. Portions of the interior of larger islets have been excavated to form shallow freshwater pits where taro, a staple root crop, is cultivated. Shoreline areas support typical beach strand vegetation, which is common throughout the Central Pacific. There is little information on whether the Marshall Islands contains unique, endemic or endangered plant species.

○ Terrestrial fauna

As with most atolls of the Pacific, the Marshall Islands has a very species poor land fauna. The Polynesian rat is the only land mammal native to the Marshall Islands, although this arrived with early settlers. Limited information on the reptile fauna indicate 7 species of lizard and 1 species of blind snake, none of which are endemic to the Marshall Islands.

There is virtually no information on the terrestrial invertebrates of the Marshall Islands. The coconut crab is widespread, although declining in abundance on inhabited atolls due to its popularity as a food item.

○ Avifauna

Some 70 bird species have been reported from the Marshall Islands. Of these, 39 are land or freshwater birds which inhabit the country for part of the year or are migratory. No endemic species or passerine species are known from the Marshall Islands, however two native forest birds are rare. One of these may be extinct and the other is classified as endangered. Seabirds form an important part of the avifauna of the Marshall Islands, with 15 species nesting and breeding, primarily in the northern atolls.

○ Marine flora

The marine flora of the Marshall Islands is a subset of the marine plant communities of higher diversity which occur further to the west in the Pacific. Only a few of the southern, wetter atolls in the Marshall Islands have small mangrove stands. Seagrass beds are relatively rare, with limited areas on a few atolls. The algae of the Marshall Islands are relatively well known, with 238 species of green, brown, red and blue-green algae recorded.

○ Marine fauna

As with the marine flora, the marine fauna of the Marshall Islands is part of the continuum of marine diversity which decreases from west to east across the Pacific. There are no known unique or endemic marine species.

Coral reef surveys have documented relatively high diversity of reef corals, with 180 coral species from 60 genera in the southern Marshall Islands. Coral reef diversity also includes the diverse assemblage of sponges, clams, oysters, mussels, gastropods, tunicates, worms, crabs, shrimps, sea cucumbers and starfish. These include many species that are important for subsistence and potential commercial use. Giant clam stocks are declining in the Marshall Islands, as elsewhere in the Pacific.

The Marshall Islands marine environment contains over 250 species of reef fish from 50 families, most of which are used as food sources. Pelagic species, particularly tuna, are also abundant and have important commercial value.

The world's 5 marine turtle species all occur in the Marshall Islands. The Hawksbill and Green turtle both nest in the country; the former is rare and endangered. As many as 27 species of whales, dolphins and porpoises occur in Marshall Islands' waters.

○ Special ecological areas

There are no "special ecological areas", as defined in the Common Methodology, (IPCC, 1991) in the Marshall Islands. As of early 1992, no national parks or nature reserves had been declared. There is international conservation interest in several northern atolls due to their nesting seabird and marine turtle populations. There are some traditional controls on resources and special areas, but these are poorly documented.

3.1.2 *Majuro Atoll*

Majuro Atoll is generally representative of the natural systems described for the Marshall Islands as a whole. This includes typical geomorphology, landform, elevation, soil and hydrologic conditions. Study Area 2 is a relatively large land mass and supports a significant freshwater lens.

Majuro has terrestrial flora and fauna typical of the Marshall Islands and Central Pacific atolls in general. These have been much disturbed by the high population level and density and the accompanying effects of human habitation and development in parts of the island. The remaining areas of significant native forest stands are indicated in the Majuro Atoll Coastal Resource Atlas (Manoa Mapworks, 1989). There are no major seabird breeding colonies on Majuro.

The marine flora and fauna of Majuro Atoll are generally typical for the country. A total of 146 species of corals from 50 genera and sub-general have been recorded at the atoll. There is little mangrove at Majuro, although there is an interior mangrove stand in Study Area 1 (Spenneman and Lajuan, 1990). A significant seagrass bed is found on the lagoon side of Study Area 2. There are no major marine turtle nesting or breeding areas at Majuro Atoll, although marine turtles frequent the lagoon and reefs of Majuro.

Majuro Atoll has are no "special ecological areas", i.e. no natural systems parks or reserves. However, a number of proposed marine parks or reserves are suggested for locations which have been identified to have potential value as marine protected areas (Manoa Mapworks, 1989). A number of seabird nesting sites have been identified also. There are numerous archeological, cultural and historic sites scattered throughout the atoll and sites with potential for nature based tourism have been identified (Manoa Mapworks, 1989). No substantial population of rare or endangered species of plants or animals is known to occur on Majuro Atoll.

The characteristics of the natural systems of each of the four Study Areas is described in more detail below and the characteristics are summarised in Table III-1.

Table III-1: Natural system characteristics

Aspect of system	Majuro Atoll	Study Area 1	Study Area 2	Study Area 3	Study Area 4
Water resources	N/A	none	major aquifer	runway catchment	none
Terrestrial flora and fauna	typical of Mar.Is.	typ. Majuro	typ. Maj.	typ. Maj.	typ. Maj.
Avifauna (no. of spp.)	70	?	?	?	?
Sea bird nesting sites	yes	no	no	no	yes
Corals (no. of spp.)	140	?	?	?	?
Mangrove	yes	yes	no	no	no
Marine turtle nesting	no	no	no	no	no
Proposed marine protected area	yes	1	0	2	1
Archeological sites	many	0	0	0	many
Historic and cultural sites	many	10	7	0	6
Level of disturbance	high	high	moderate	high	low

3.1.3 Study Area 1

○ Terrestrial

Very little of the terrestrial environment of Study Area 1 has not been disturbed by the urban development on this part of Majuro. No significant stands of native forest are found in the area. A small stand of *Bruguiera* mangrove occurs in a swampy area with brackish water, but these may have been transplanted there. Six historical/cultural sites and no archeological sites have been identified in the area.

Large portions of Study Area 1 were leveled and paved to form the former airstrip for Majuro. Additional terrestrial area has been created by the causeways which link the three islands in the area and by shoreline landfills. Some of the landfills are substantial, such as in the area of the commercial port and tank farm, while others are small landfills undertaken by landowners to create more land. The overall width of the land mass in Study Area 1 varies from the width of the causeway and road which links the islets to a maximum of about 0.45 miles wide.

○ Shoreline

A detailed description of the shoreline in Study Area 1 is presented in Annex 3. The general shoreline on the ocean side is a beach of gravel, cobbles and boulders, with some coarse sandy areas. A gravel berm tossed by storm waves is common along the shoreline. The beach crest elevation on the ocean side ranges from 7 to 10 feet above mean sea level with an average height of 8 feet. Along a large section of shore, flat reef rock is located up to the shoreline.

Houses are built right at the beach top and only a small percentage of individual properties are protected. A vertical seawall is commonly used for shore protection. The seawalls are typically not adequate for shore protection against severe storm waves. Unprotected shorelines show signs of erosion, such as exposed tree roots, toppled trees and an erosion scarp.

A January 1992 storm caused shoreline damage along the south shore of Telap, especially at the Telap fuel tank area. Armor stones of the revetment at the fuel tank area were significantly moved out of position, damaged filter cloth is exposed and earth behind the revetment is eroded. The storm waves appeared to have reached the toe of fuel tanks, where the ground elevation is over 10 feet.

The lagoon side shoreline is more populated and more individual properties are protected by using a vertical seawall. A few land fill areas use gabion walls and sand bags for shore protection. Beaches are narrow and commonly consist of gravel and coarse sand. Segmented and narrow fine sand beaches are found on Telap. Signs of shoreline erosion are also found throughout the lagoon coast in this area, including erosion scarps, tree root exposure and toppled trees. Shoreline retreat is commonly observed along unprotected shoreline reaches between sections protected by seawalls. Significant beach erosion occurs along the park area on Telap, where an erosion scarp is up to three feet high, trees have fallen down and earth behind the vertical wall is eroding.

○ Marine

Along the eastern facing part of Study Area 1, the oceanside reef flat is fairly uniform in width, ranging from 400 to 1000 feet wide. At the southeast corner of the atoll and around to the east, the oceanside reef flat is considerably narrower. In places along the southern facing shore landfills with shore protection extend virtually out to the reef edge, completely covering the former reef flat. A series of old, pre 1944, quarry sites are located near the shore along the oceanside reef flat. These are too shallow (1-4 feet deep) and too close to shore to allow new coral development and the substrate has high levels of benthic algae cover.

Much of the inshore portion of the oceanside reef flat, especially along the east facing part of the area, has a conglomerate ramp or platform. The conglomerate platform extends several hundred feet out onto the reef flat in places and at the north end of the Study Area it is 1-1.5 feet higher than the adjacent reef flat. Otherwise the reef flat is a solid, fairly level platform which is exposed at low tide. There is little coral growth or sediment accumulation on the reef flat. Turf algae cover is extensive, with numerous brittle stars, small gastropods, small crabs and *Echinometra* urchins.

The oceanside reef flat in Study Area 1 has low reef fish diversity. There is low subsistence fishing potential and the habitat is generally considered to be poor, with a high level of disturbance. Nonetheless, the high population pressure in the area ensures that the limited resources available are harvested. The east facing portion of the reef does support reef gleanings for lobster, conch and turban shell. The outer reef slope supports fishing for a variety of reef fish. Further offshore, tuna and other pelagic fish are taken.

The lagoonside reefs generally have a terrace or gentle slope of silt, sand and rubble along the inshore portion. This often supports *Padina* and *Dictyota* algae cover and synaptid and other sea cucumbers. Where there is no significant hard substrate development, the sediment slope descends gradually with very low coral cover on occasional reef blocks with scattered larger *Porites* coral heads on the slope.

Where there is suitable substrate for coral development, variable cover of 5-25% is found on the rock and rubble bottom, mixed with *Dictyota* algae. In some areas of adequate water quality and substrate, coral cover of greater than 50% occurs, consisting mainly of branching *Porites*. Digitate *Acropora* and small massive *Porites* mounds are also relatively abundant or common.

The fish habitat of the lagoonside reefs of Study Area 1 is generally in poor condition, polluted and over-fished. There is a high level of fishing pressure, with various reef fish and octopus harvested from the area. Reef fish diversity is low.

Along the central portion of the lagoonside reef, a few small patch reefs are located a short distance offshore. Two historic/cultural sites have been identified on these reefs. At the far northern end of the lagoonside in this area, a potential marine tourism site has been identified.

3.1.4 Study Area 2

○ Terrestrial

The large land mass of Study Area 2 is dominated by coconut plantations, with interspersed taro pits. No significant stands of native forest are identified in the Laura area. Coconut crabs are relatively abundant along the western portion of the widest area of Laura. Seven historic/cultural sites are found in the area and no archeological sites have been identified. The land mass reaches a maximum width of about 0.80 miles wide and narrows to a few hundred feet at the southern end.

The relatively large land mass supports a significant freshwater lens. The potable fresh water has less than 2.6 percent saltwater content. Hamlin and Anthony (1987) calculate fresh groundwater storage in the lens is 450 to 550 million gallons and estimate that a sustainable yield of 400,000 gallons per day can be extracted from the lens. The water is pumped out of this lens and trucked to urban Majuro. This water source is extremely important to Majuro, which presently uses between 750,000 and 1.2 million gallons per day, depending on the length of water hours.

○ Shoreline

A detailed description of the shoreline of Study Area 2 is presented in Annex 3. The south end of the ocean side shoreline is a sandy beach, consisting of fine to medium grain size sand. The beach is about 50 feet wide with a slope of 1/10. The fine sandy beach continues a half mile westward. The beach grain size becomes increasingly coarser and the beach width narrows further west. A half-mile from the west end of the island, the beach consists of coral gravel and cobbles. The beach width is 30 feet with a beach slope of 1/5.

At the west tip of the island, towards the north, flat reef rock emerges at the shoreline with scattered gravel, cobbles and boulders. The shoreline slope is about 1/4. Approaching the north end of the island, the shoreline again becomes sandy. At the north tip of the island the beach of fine to medium sand widens to over 100 feet wide with a beach slope 1/10. The lagoon side of the shoreline is a consistent sandy beach with fine to medium sand, and the beach slope is 1/10.

Evidence of ongoing erosion was commonly observed along the entire shoreline on both the ocean side and the lagoon side, including exposed tree roots and toppled trees on the beach. A beach scarp two feet high occurs at the north tip of the island. No shore protection structures were observed in Study Area 2. The beach crest elevations are about 11 feet on the ocean side and 5.5 feet on the lagoon side.

○ Marine

The oceanside reef of Study Area 2 consists of a reef flat over 1/2 mile wide at the northern tip of Laura. This gradually narrows to the south, and at the westernmost point of Laura the reef flat is only a few hundred feet wide. Near the northern tip of the island sand can be up to 50% of the bottom cover, the rest being rubble and coral. The coral is mainly *Porites* microatolls and digitate *Acropora* further oceanward. Elsewhere on the ocean side, the inner reef flat is a solid limestone platform with very little coral cover, primarily occasional small *Porites* colonies, and little sediment. Algal cover is sometimes dense further out on the reef flat, consisting of *Caulerpa*, *Padina* and *Dictyota*. The middle portions of the reef flat have high coverage of *Caulerpa*, with some patches of low, branching *Montipora* coral. The reef flat rises slightly towards the reef edge and continues to support *Caulerpa* into the wave zone.

The southern portion of the oceanside reef in this area is characterised by a narrow, solid reef flat, also with no sediment accumulation and little coral growth. Portions of the inner reef flat support a turf algae with fine sand. *Caulerpa* continues to be the dominant algae. As the solid reef flat slopes into the surf zone, encrusting and low digitate *Acropora* colonies can attain to 10% cover.

The oceanside reef flat supports moderately low reef fish species diversity, with surgeonfish and mullet abundant. The ocean waters of this area support a high level of fishing for both pelagic and reef fish.

The lagoonside reef flat of this area is also about 1/2 mile wide at the northern tip of the island, but remains fairly wide to the southern end of the Study Area. Much of the lagoonside reef is a moderately deep reef hole. The lagoonside reef flat consists of a sand flat that grades into a sand and rubble flat with mixed seagrass and algae (*Padina*, *Halimeda*, *Dictyota*) cover and large numbers of *Holothuria* sea cucumbers. About mid-way across the reef flat, there is mixed coral cover, mainly small *Porites* mounds and digitate *Acropora*, and *Caulerpa* algae. The reef flat gradually deepens and some larger *Porites* mounds occur. The outer reef had areas of significant coral cover, up to 80%, consisting of branching *Porites* and *Pocillopora* and digitate *Acropora*. Some *Tridacna maxima* are also found here.

The narrow reef flat adjacent to the reef hole supports dense seagrass beds and patches of *Dictyota* algae. The sand bottom slopes rapidly into the sandy reef hole, which has scattered reef patches. These patches support high coral cover, often monospecific stands of *Porites rus*. Other patches support thickets of fine branching *Millepora*, branching *Porites* and digitate *Acropora* on the shallow areas, the upper portion of the patches often being dead. Relatively large *Porites* mounds are scattered on the sand bottom of the reef hole in places.

Reef fish diversity is moderate on the lagoonside reef flat, with large numbers of surgeonfish. Subsistence fishing potential is considered moderate in the lagoonside reef of Study Area 2. Sites with potential for marine tourism have been identified on the oceanside reef flat at the north tip of Laura and at the edge of the lagoonside reef drop-off.

3.1.5 Study Area 3

○ Terrestrial

The eastern portion of the terrestrial environment of Study Area 3 has been completely altered by the construction of the airstrip, which also serves as a water catchment, and airport facilities. This has included extensive land fill and reclamation. The central portion of the area consists primarily of artificial causeways and narrow landfill. The causeways link the islet of Majuro, immediately to the west, with the airport area. The western portion of this Study Area is a long, narrow islet dominated by coconut trees. This is typical of the long, narrow islets which make up a major portion of many of the atolls of the Marshall Islands and elsewhere in the Pacific.

Overall, the land mass in this area varies from the width of the causeway and road to only about 0.15 miles wide. There are no significant native forest areas or other terrestrial resources. No historic, cultural or archeological sites have been identified in Study Area 3, although a war memorial has been constructed near the western end of the causeway.

○ Shoreline

A detailed description of the shoreline of Study Area 3 is presented in Annex 3. A 1.7-mile long rubble mound revetment protects each side of the shoreline along the airport. According to the airport construction plan, the crest elevation of the revetment is 8 feet and the road along the runway is 4.5 feet above mean sea level. The revetment side slope is 1 on 2. The armor quarry stone is 1 to 4 tons for the ocean side revetment. A storm in January 1992 caused some damage on the ocean side, shifting the armor stones from their original position. Earth erosion behind the revetment suggests that the storm waves overtopped the revetment. The lagoon side revetment is armored with smaller quarry stone, 0.5 to 2 tons. No damage was noted on the lagoon-side revetment.

The total length of causeway in Study Area 3 is about 1.5 miles. The causeways are protected by riprap revetment, which appeared to be in good condition, with a stable slope of about 1 on 2. The causeway elevation is 4.5 to 5.5 feet and the revetment crest is 7 to 8 feet. Vegetation along the causeways suggests that waves do not frequently reach the top of the revetment.

Islands in Study Area 3 connected by causeways are not protected by shore protection structures. Beaches on the ocean side generally consist of gravel and cobble with beach slope of 1/3. The beach crest elevation is about 10 feet above mean sea level. The lagoonside beach has a gentle slope of 1/10 with a beach width of 50 to 70 feet. It consists of fine to medium sand with a small percentage of gravel and cobbles. The beach crest is again up to 10 feet above mean sea level. The shoreline shows signs of erosion on both the ocean and lagoon sides of the islands, including tree root exposure, toppled trees and a beach scarp. The beach erosion rate appears to be greater on the lagoonside shoreline, where the beach scarp is from 2 to 3 feet high.

○ Marine

The oceanside reef of Study Area 3 is a narrow reef flat a few hundred feet wide. The solid reef flat is completely exposed at low tides and supports no coral cover. The middle portion of the Study Area, where the islets have been joined by the causeway, there is a conglomerate beach rock zone midway across the present reef flat, indicating the former presence of islets. Some parts of the outer oceanside reef flat have accumulations of coral rubble immediately before the wave zone. The eastern end of the oceanside reef flat in this area has reef rock quarries. These support high algal cover, especially coralline algae. Holothurian and synaptid sea cucumbers are common.

The lagoonside reef flat is of similar dimensions to that of the oceanside. The reef flat in the western portion of the Study Area is a solid reef flat, with turf algae, that grades into a mixed rubble and sand platform of irregular relief. This supports low coral cover, mainly encrusting and low, digitate *Acropora* and small *Porites* mounds and contains numerous gastropods. As the irregular reef surface dips into the wave zone, coral cover can reach 60-80%. The reef front rapidly drops off into a sand and rubble slope that extends broadly into the lagoon.

The lagoonside reef flat in the middle portion of the area is similar to the oceanside reef flat. The two reef flats are separated only by the causeway. A large beachrock platform occurs mid-way across the reef flat, indicating that the area supported islets for some period of time. A narrow reef flat extends into the lagoon from the 3 feet high beachrock ramp. An older beachrock ramp is exposed along the shore of the causeway. The lagoonside reef flat adjacent to the airport runway and reservoir has been completely obliterated in places, due to the extensive filling which has taken place on the reef flat to create land.

The oceanside reef flats are not very important for subsistence fishing. The ocean waters offshore of this area support important pelagic fisheries. The lagoonside reefs support moderate to high reef fish species diversity. Rabbitfish, parrotfish, goatfish, surgeonfish, snapper and rudderfish are particularly abundant.

Sites with potential for marine tourism have been identified on the reefs on either side of the airport runway.

3.1.6 Study Area 4

○ Terrestrial

The land mass in Study Area 4 is broken up into approximately 11 small islets. This series of small fragmented islets is typical of many portions of atolls in the Marshall Islands and elsewhere in the Pacific. The largest islets are only 0.13 miles wide at the most and are mainly covered with coconut palms and shoreline strand vegetation. The smallest islets are sand and rubble cays no bigger than a few hundred feet in diameter, with little or no vegetation.

Two areas of significant native forest and a seabird site have been identified in the two islets at the northwestern end of this area. Land crabs are relatively abundant on one of the islets. Seven historic/cultural sites and five relatively large archeological areas occur among these islets.

○ Shoreline

The shoreline of the numerous islets in this area consist of reef conglomerate platforms on the ocean front and sides of the islets which are built of cemented coral rubble, cobble and plates. These are fairly continuous along the ocean side of the islets and vary in width from about 25-35 feet to much wider. The wider conglomerate areas occur especially at the ends of the islets, where increased sand accumulation forms extensions of the land mass out towards the lagoon. The conglomerate often grades into a conglomerate ramp or beachrock at the shore.

Oceanside shorelines are generally composed of large coral cobble and plate, with some sand accumulation especially where the conglomerate is widest. A 1 foot erosion scarp, with older rubble and coconut tree roots exposed, sometimes occurs at the back of the cobble beach on the ocean and side portions of the islets. In the few areas where the conglomerate platform is narrow or absent active erosion of the modern cobble beach appears to be occurring.

The lagoonside shoreline of the larger islets is generally composed of moderate to fine sand, with beach rock exposed along much of the lower beach. The smaller islets have cobble and plate beaches, often with a reef rubble conglomerate along the base of the beach. The upper beach of the smaller islets is generally rubble, with a low erosion scarp at the corners of the islet. Rubble and gravel banks extend lagoonward from the islet corners.

○ Marine

The oceanside reef flat is over 1000 feet wide in this area. A solid reef flat extends seaward from the conglomerate platform with no coral or algal growth. The platform is slightly deeper at the outer third of its width, where it is composed of cemented rubble with an algal turf cover. Beyond this, a well developed algal ridge extends up into the wave zone, especially in reef flat areas in front of islets. In between the islets, the reef is a scoured reef flat where rapid currents are concentrated between the raised reef conglomerate on either side.

The lagoonside of the islets has a 20-100 feet wide reef flat. This drops off onto a shallow sand and rubble terrace 3-6 feet deep. The terrace has scattered coral patches and coral heads. The coral is predominantly *Porites* mounds, branching *Porites* and *Porites rus* colonies, with some digitate *Acropora* and *Goniopora* in areas of higher cover. The coral colonies often form microatolls closer to the reef flat. Towards the lagoon, the terrace becomes a broad sand slope which descends into the lagoon depths, with scattered large *Porites* mounds on the upper slope.

At the areas between islets, where rubble and gravel extensions of the islands reach into the lagoon, the reef reaches further into the lagoon. The gravel deposits encroach directly on to the broad sand lagoon slope as it starts to descend into the lagoon, and there is little coral.

Moderately high diversity of reef fish occur on the lagoon reefs in Study Area 4. Surgeonfish, goatfish and parrotfish are particularly abundant. There is some pelagic fishing, especially for tuna in the ocean and lagoon waters of the area. A potential marine park and a site with potential for marine tourism have been identified on the lagoonside of the northwestern portion of Study Area 4.

3.1.7 Shore protection facilities

Existing types of shoreline structures in the Study Areas are typically quarystone armor revetment, riprap revetment, vertical concrete wall, vertical masonry wall or gabion and sandbag wall. A quarystone armor revetment exists along the shorelines of the airport and a Telap fuel tank area. The revetment on the oceanside of the airport and at the fuel tank area were damaged by storm waves in January 1992. The revetment at the fuel tank area is heavily damaged.

A riprap revetment of smaller stones is more commonly used than a quarystone armor revetment. It is used along causeways and at a land fill area. The riprap along causeways appears to be in good condition, but the riprap at the land fill area is generally providing poor shore protection.

A vertical concrete or masonry wall is the most common shore protection structure for individual property owners in Study Area 1. Many of them, however, do not provide an adequate shore protection against severe storm waves. They may not be strong enough or high enough to protect houses from storm wave attack. Field investigations showed many damaged seawalls and earth erosion behind the walls.

At a few land fill areas, gabion (wire mesh baskets filled with small stones) walls are used for shore protection. At one location sandbags are placed at a damaged shoreline section. Table III-2 summarizes existing shore protection structures.

Table III-2: Shoreline with shore protection structures.

	Shoreline length protected (feet)			Total
	Quarystone Armor Revetment	Riprap Revetment	Seawall	
Study Area 1:	1700	3900	8700	14300
Ocean	1300	3700	2600	7600
Lagoon	400	200	6100	6700
Study Area 2:	0	0	0	0
Study Area 3:	18200	15000	0	33200
Ocean	9000	7500	0	16500
Lagoon	9200	7500	0	16700
Study Area 4:	N/A	N/A	N/A	N/A
Total	19900	18900	8700	47500

3.2 Characteristics Of Socio-Economic System

3.2.1 National economy

○ Overview

Growth of the national economy is restricted by an exceptionally high population growth rate, an inadequate supply of skilled labor, a limited natural resource base, the geographical isolation of the Marshall Islands from world markets and isolation of the atolls from each other. The country relies heavily on foreign imports, expertise, and aid. The ratio of imports to exports is 19:1, which reflects the growing reliance on foreign goods. Domestic production, consisting primarily of copra, cannot measure up to imports, resulting in an increasing deficit.

A cash economy, fueled by aid transfers, is rapidly displacing the traditional, subsistence-based way of life. Although subsistence agriculture and fisheries still supports an average of 50 people per acre, two-thirds of the population now lives in urban areas, where the majority of food consumed is imported (OPS, 1991b). The subsistence economic base is eroding and urbanization, spurred by a disparity between rural and urban income levels, is proceeding rapidly.

The Exclusive Economic Zone (EEZ) of the Marshall Islands encompasses over 750,000 square miles of the central Pacific ocean. This area contains abundant living and non-living marine resources, including one of the world's top three reserves of cobalt and manganese and cobalt crust (Callies and Johnson, 1989). Efforts to exploit these resources for economic gain are still embryonic.

○ Gross Domestic Product

The Gross Domestic Product (GDP) more than doubled during the past decade, from \$ 31.9 million in 1981 to \$ 68.7 million in 1988 (OPS, 1989b). Although this represents an annual rate of increase of nearly 12%, actual growth is approximately 5.9% per annum. GDP is significantly inflated by foreign aid. In 1991, roughly 78%, or nearly \$50 million, of current total national revenue was foreign aid. The Asian Development Bank estimated actual GDP at approximately \$ 25 million, or an actual per capita GDP of between \$200 and \$500 per annum (ADB, 1991). The real economy is dominated by a large service sector and is largely sustained by the national government and the U.S. Army Facility at Kwajalein Atoll, which are the sources of at least 40% of GDP.

○ Future economic development

Future economic development is largely dependent on marine resources. Copra holds little promise for economic growth, although government subsidies continue to support its production on outer atolls. On-going efforts under the Second Five Year Development Plan (1992-96) include projects oriented toward mariculture and artisanal fisheries development, sea-bed exploration and establishment of a long-line fishing fleet. It is hoped that outer-island production of trochus, black-lip pearl oysters, giant clams and sponges, which are worth more per pound than copra, will be successful. This would help to make inter-island shipping competitive, perhaps resulting in its privatization.

The Marshall Islands' vast EEZ may eventually ease the nation's dependence on foreign aid. However, current demographic patterns of rapid population growth will force the nation to concentrate on building infrastructure and providing basic services. These factors compromise the country's potential for economic self-sufficiency.

○ Relevant development factors

Based on recent trends, rapid socio-economic change can be expected in the Marshall Islands in the near future. Assessment of the socio-economic impacts of sea level rise was carried out based on a projection of selected socio-economic variables into the year 2022, thirty years from the present being the generally accepted outer limit of planning efforts. The following variables were used as a basis to describe and project socio-economic development in the Marshall Islands: population size and distribution, land use and productivity and capital investment levels. Current characteristics of the socio-economic system of the Marshall Islands and those projected for 2022 are presented in Table III-3.

Table III-3: Socio-economic system characteristics.

<i>Types of Data</i>	<i>Units</i>	<i>Marshall Islands</i>	<i>Majuro Atoll</i>	<i>Study Area 1</i>	<i>Study Area 2</i>	<i>Study Area 3</i>	<i>Study Area 4</i>
1. Land area	sq. mi.	70.0	3.75	0.8	1.2	0.4	0.2
1.1 Total dry land	acres	44,835	3,402	510	740	230	130
1.2 Agriculture	acres	220,000	960	160	450	-0-	320
2. Exclusive Economic Zone	sq.mi	750,000	6.0				
3. Gross Domestic Product							
3.1	US\$	68.7M (199.6m)	.54.0m (156.8m)	40.2m (116.7m)	4.3m (12.5m)	7.9m (18.5m)	52.2th (651.7th)
3.2 Growth rate	%/yr	5.9(1.0)	N/A(1.0)	N/A	N/A	N/A	N/A
4. Population							
4.1 Total	#	43,380 (165,000)	19,664 (73,500)	14,649 (54,300)	1,570 (5,900)	-0-	19 (160)
4.2 Density	#/sq.m i.	620 (2,400)	5,240 (19,600)	18.310 (67,900)	1,310 (4,900)	-0-	95 (800)
4.3 Subsistence	#	12,880	1,420	180	1,020	-0-	19
4.4 Growth rate	%/yr	4.2 (3.4)	5.0 (3.4)	N/A	N/A	N/A	N/A
5. Capital value							
5.1 Total	US\$	N/A	175m (303b)	158m (2.73b)	17.5 (302.6m)	8.7m (150.6m)	-0- 1.1m
5.2 Growth rate	%/yr	N/A (12.0)	7.5				
6. Import vs. Export Earnings	ratio	19.1	N/A				
7. Foreign Aid							
7.1 Total annual aid	US\$	49.0m (100m)	1.3m				
7.2 Aid as % of GDP	%	78 75	N/A				
8. Land Use							
8.1 Agriculture	Acres	23,874	1,100	150	590	50	100
8.2 Urban	Acres	600	510	510	-0-	-0-	-0-

<i>Types of Data</i>	<i>Units</i>	<i>Marshall Islands</i>	<i>Majuro Atoll</i>	<i>Study Area 1</i>	<i>Study Area 2</i>	<i>Study Area 3</i>	<i>Study Area 4</i>
8.3 Essential Infrastructure							
a. Port/Airport	Acres	135.5	132.5	7.5	125	125	N/A
b. Power station		18	10	10	0.3	0.3	N/A
c. Telecomm.		6.5	7.3	6.3	1.0	1.0	N/A
8.4 Tourism	Acres	1,024	804	689	-0-	-0-	-0-
8.5 Fisheries	Acres	30,000	2,500	490	740	510	470
8.6 Industry	Acres	50	30	20	5	-0-	-0-
8.7 Forestry	Acres	N/A	N/A	N/A	N/A	N/A	N/A
9. Subsistence Land Use							
9.1 Agriculture	Acres	35,548	1,281	N/A	450	-0-	130
9.2 Fisheries	Acres	78,366	2,500	N/A	700	-0-	450
10.1 Agriculture	US\$	8.9m	1.5m				
10.2 Urban	US\$	2.3m	1.0m				
10.3 Essential infrastructure							
a. Port/Airport	US\$	27.0m	13.7	5.0m	-0-	8.7m	-0-
b. Power station		85.0m	51.5m	50.m	-0-	1.5m	-0-
c. Telecomm.		15.8	12.8m	12.8m	N/A	N/A	N/A
10.4 Tourism	US\$	3.5m					
10.5 Fisheries	US\$	6.5m					
10.6 Industry	US\$	2.0m					
10.7 Forestry	US\$	N/A					
11. Subsistence Value							
11.1 Agriculture	People /acre	41	76.8				
11.2 Fisheries			93				

3.2.2 Population: Marshall Islands and Majuro Atoll

The 1988 Marshall Islands population was 43,380 with two-thirds of the population concentrated in the two urban centers, Majuro and Ebeye (OPS, 1989b). Growth rates from 1980-88 were exceptionally high by world standards with an annual rate of 4.2 % in the nation as a whole and 6.3% in Majuro Atoll. Population and area and density for each of the islands in the nation are given in Annex 4.

The nation's average population density, at 600 per square mile, approaches that of India. In 1988, Majuro, the capital atoll, was home to 19,664 people, or 45.3% of the national population (OPS, 1989b). The rapid population growth of Majuro is due, in part, to immigration. Total population for the Marshall Islands and the rate of increase from 1920-1988 is summarised in Table III-4.

The National Population Policy of 1991 examines the potential economic, social, and environmental ramifications of continued rapid population growth and urbanization. Projections are made for three scenarios: 1) a continuation of the present population growth rate (4.2% per annum), 2) a moderate decrease in growth rate (to 3.6 % per annum), and 3) a marked decrease in growth rate (to 3.4 % per annum). At least a moderate decrease is shown to be desirable to curb growing problems with unemployment, education, infrastructure, etc (OPS, 1991b).

Table III-4: Marshall Islands population and rate of increase (1920-1988)

Census Year	Total Population	Intercensal Increase (%)	Average Annual Growth Rate (%/yr)
1920	9,800	--	--
1925	9,644	-1.6	-0.32
1930	10,412	8.0	1.53
1935	10,446	0.3	0.07
1958	13,928	33.3	1.25
1967	18,925	35.9	3.40
1973	24,135	27.5	3.76
1980	30,873	27.9	3.52
1988	43,380	40.5	4.17

3.2.3 Population: Study Areas

○ Study Area 1

Nearly 15,000 people, almost 80% of Majuro's population, live in Study Area 1 which has an exceptionally high population density of 28,724 people per square mile (OPS, 1989b), five times the average for Majuro. About five miles long and varying in width from 100 to 1,500 feet, the D-U-D area is the commercial and population center of Majuro and the seat of the Marshall Islands government. Houses are built very close together, little land is available for building, gardening, or recreation and overcrowding is already a serious problem.

○ Study Area 2

Study Area 2, the agricultural center of Majuro Atoll, encompasses roughly 50% more land than Study Area 1. The area has less than 10% of the population of Majuro Atoll, only 1,575 inhabitants. This yields a population density well above the national average, at 1,313 people per square mile. Population growth rate has not been specifically measured for the Laura area. It is most likely higher than the national average, as the availability of arable and buildable land and the recently enhanced availability of electricity and fresh water will enhance migration to the area in the near term.

○ Study Area 3

Study Area 3 does not have any permanent inhabitants or settlement.

○ Study Area 4

Study Area 4 is composed of a string of motus and sandy cays which support 19 inhabitants (OPS, 1991a). This yields a population density of well below the national average, at 95 people per square mile.

3.2.4 Land use patterns and productivity levels: Marshall Islands and Majuro Atoll

○ Land Tenure System

With less than 70 square miles of land in the entire Marshall Islands, and limited prime settlement areas, land is the most highly prized possession in the Marshall Islands. Historically the Marshallese lived a subsistence lifestyle centered about reef gleaning and horticulture, which still prevails on most outer atolls (i.e. other than Majuro and Kwajalein). Approximately 53 people per square mile subsist on agricultural and fisheries activities (OPS, 1991c).

Land is composed of sections of varying width which run from ocean to lagoon across the narrow land mass. These ownership parcels, called "wetos", usually contain two to five acres. The wetos are held communally by lineage ("bwij") members, who traditionally cleared and tended the land for subsistence agriculture. Even today social position is derived according to both present and future land ownership rights.

Typically, each member of the *bwij* holds one of four recognized social positions with respect to the *weto*, being either the *Irooj-laplap* (Paramount Chief of certain lands), the *Irooj-edrik* (Lesser Chief of certain lands), the *Alap* (person with immediate management responsibility for the land), or *Dri Jerbal* (worker on land). The majority of land is matrilineally inherited, *bwij* members tracing descent from a common *Alap* ancestress (Tobin, 1958). In the Marshall Islands Constitution, traditional rights of land tenure are unequivocally preserved, and the traditional requirement of consensus decision-making, in which all persons with land rights to a certain *weto* must agree on questions of land transfer, is retained.

○ Agricultural and urban land use

Agro-forestry has long been a primary component of the nation's agricultural productivity. Copra has been the primary export for the last 100 years. Coconut groves, many of them planted near the turn of the century, cover 22,000 acres, i.e. almost 50% of the land, although only about 11,000 acres are estimated to be fully productive (OPS, 1991c). Approximately 200 acres of land is covered with stands of other tree crops, including bananas, papayas, breadfruit, and pandanus, and an additional 500 acres of land are utilized for the cultivation of vegetables. Table III-5 summarises land use by acreage for the Marshall Islands.

The value of national agricultural production in 1988 was estimated at nearly \$ 9 million. Of this total, \$ 6 million, or 67.2%, was consumed rather than marketed, and \$ 2.3 million, or 26%, was cultivated in urban areas. Of the two urban areas, Majuro and Ebeye, Ebeye has virtually no land available for food cultivation, so one can safely assume that the overwhelming majority of urban agricultural production is attributable to Majuro.

The national capital was shifted to Majuro Atoll in 1947. The majority of infrastructure investment has been centered there since that time. Majuro is the heart of the Marshallese economy, being the most important link to world markets, and the supplier of tertiary education, social and health services.

Table III-5: Land use by acreage (1991)

Crop/Use	Land Area (Acres)	% of Total Land Area
Coconut	22,000	49.1
Pandanus, Breadfruit	1,264	2.8
Banana, Papaya, Other Fruits	200	0.4
Taro, Sweet Potatoes, Arrowroot	300	0.7
Vegetables, Cucumber, Cabbage, Pumpkin, Others	110	0.2
Ruinat (Urban Area, Fallow Land, Sandy Soil, Bush, etc.)	20,925	46.8
Total	44,799	100.0

3.2.5 Land use and productivity: Study Areas

Since GDP figures were unavailable for the four Study Areas, estimates were derived by assuming that the proportion of an area's population to that of the entire atoll is equal to that of its GDP. Study Area 3 was treated as a special case, as it has no population and its productivity is totally derived from the international airport.

○ Study Area 1

Land in Study Area 1 is primarily high-intensity urban uses, being the site of the bulk of the nation's industry and services, containing water and power plants, two commercial ports, the majority of government buildings and businesses and housing for the majority of the nation's commercial workforce. Nearly 75% of Majuro's population lives in Study Area 1. Assuming 75% of Majuro's GDP originates here values the area's productivity as \$40.2 million.

○ Study Area 2

Approximately 80% of the land in Study Area 2, Majuro's most important agricultural area, is used for light-intensity, non-irrigated agriculture. This includes the cultivation of coconuts, taro, yams, papayas, breadfruit and green vegetables, and the raising of pigs and poultry. The remainder of the land is roadways, buildings, uncultivated land, sandy soil, bush, etc. The people of Laura obtain a higher price for their copra than the people of outer atolls, and an increasing percentage of the residents of Laura work in Study Area 1, 30 miles away. As approximately 8% of the population of Majuro lives at Laura, an estimated \$ 4.3 million of the total GDP originates there.

○ Study Area 3

Study Area 3 is mainly a long continuous causeway and built-up area containing the international airport. An estimate of the productivity of the airport, the nation's only air-link to international markets, is not available. However, estimates of cash flow generated by the airport total approximately \$ 200,000 month, or \$ 2.4 million a year. An estimated profit margin of 33% yields a GDP of \$ 7.92 million for the area. Approximately \$ 43,000 cash flow per month is generated by the export of live tropical fish, fresh tuna and giant clams.

○ Study Area 4

Subsistence agriculture and fisheries are pursued by the area's 19 inhabitants, and some remittances are received. With less than 1% of Majuro's population living in this area, the proportionate estimate of GDP is \$ 52,200. This figure is probably high, given that the people who actually live on the islands lead a subsistence lifestyle.

3.2.6 Capital value: Marshall Islands and Majuro Atoll

The Marshall Islands relies heavily on the United States for funding in the form of annual grants earmarked for capital improvements and development assistance. Direct grants provided under the Compact of Free Association during the period 1986-91 totaled \$ 130.5 million. This amount will decrease to \$110.4 during the period 1992-96, and to \$95.5 million during 1997-2001. In 2001, funding is scheduled to end, provided that the Compact Agreement is not renewed.

During the period of the First Five Year Development Plan (1986-90), infrastructure development expenditure represented 66.3% of total project expenditure, or \$ 28.7 million. Most of these funds were directed toward Majuro Atoll. Although estimates of capital investment levels were not available either for the country, Majuro Atoll or for the Study Areas, rough estimates have been made.

3.2.7 Capital Value: Study Areas

○ Study Area 1

Study Area 1 contains the majority of the nation's physical infrastructure, government buildings, businesses and housing. This includes the hospital and community college, salt water and fresh water public supply lines and electrical and phone lines. A rough estimate of the worth of all major existing infrastructure, land and housing in the area is \$ 158 million.

○ Study Area 2

Study Area 2 contains two commercial farms and a number of small piggeries. The value of major infrastructure, land and housing is estimated to be \$ 17.5 million.

○ Study Area 3

The total capital value of Study Area 3 is derived from the international airport, valued at \$ 8.7 million.

○ Study Area 4

Study Area 4 contains no significant capital investment value.

3.3 Institutional Arrangements

3.3.1 General

The importance of environmental management has gained new recognition in the Marshall Islands during the past year through two initiatives. First, a National Environmental Management Strategy has been developed by the National Task Force on Environmental Management and Sustainable Development, which has high-level representation from all sectors of the government. The strategy represents the first coordinated attempt to integrate sustainable development principles into development plans. Second, the Ministry of Health Services, in January 1992, was re-named the "Ministry of Health and Environment." In general, commitment to environmental management and planning, and general public awareness of environmental issues have both significantly increased during the past several years.

3.3.2 Existing legislation

Several national Acts pertaining to various aspects of environmental management are in effect. Acts specifically related to coastal zone and marine resource management include the Coast Conservation Act 1988 (CCA 1988) and the Marshall Islands Marine Resources Act 1988 (MIMRA 1988).

○ Coast Conservation Act (CCA 1988)

Passed in 1988, the Coast Conservation Act mandates the development of a comprehensive Coastal Zone Management Plan, naming the General Manager of the RMIEPA to be Director of Coast Conservation and thus responsible for administering this task. According to the requirements of the CCA, the Director is to submit the CZM plan within three years of the Act's passage. Unfortunately, development of the plan has not yet begun, due to staff shortages and other priorities. It is likely that the RMIEPA will be granted an extension of the deadline. Although passage of the Act has not yet precipitated the development of a CZM plan, it is nonetheless important as enabling legislation which signals the nation's commitment to the concept of coastal zone management. Development of a CZM plan was named a top priority during the period 1992-96 in the National Environmental Management Strategy (RMI, 1992).

○ Marine Resources Act (MIMRA 1988)

The Marshall Islands Marine Resources Act (MIMRA Act 1988) established the Marshall Islands Marine Resources Authority (MIMRA). MIMRA is endowed with a wide range of responsibilities, all relating to the exploitation and conservation of marine resources contained in the Marshall Islands Exclusive Economic Zone. The MIMRA has not yet developed Marine Resource Conservation Regulations pursuant to the Act. A reorganization of the MIMRA, which will take place during 1992 with technical assistance from the Asian Development Bank, is expected to dedicate increased resources to developing a conservation program, including the establishment of a marine resource data base.

3.3.3 Existing institutions

Several existing institutions deal with environmental planning and management issues and will be important in a coordinated response to ASLR. The Office of Planning and Statistics is the lead agency for national planning and routinely conducts censuses, socio-economic studies and risk assessments which are used to formulate national policy. The national Environmental Protection Authority is responsible for environmental management and conservation. Responsibility for management and conservation of marine resources is with the national Marine Resources Authority (MIMRA).

The National Task Force on Environmental Management and Sustainable Development, established by Cabinet in 1991, has oversight responsibility for the development of policies and strategies relating to national environmental management, primarily through the implementation of the National Environment Management Strategy. The National Disaster Committee is responsible for planning and coordinating disaster response. The National Weather Station provides meteorological information important to climate change issues.

IV Identification of Non-Climate Change Development Factors

4.1 Relevant Development Factors

Thirty years is the outer limit of planning capabilities, so projections to the year 2022 are a reasonable basis for indicating socio-economic impacts of ASLR. As it is certain, based on recent rates of change, that the development scenario will continue to change rapidly, predicting socio-economic impacts based on the present scenario would not be accurate. Major trends such as rapid population growth, increasing urbanization and increasing reliance on foreign goods and capital make it imperative that a future development scenario be used as a basis for predicting future impacts.

Based on current trends, declining growth rates for both population and Gross Domestic Product are projected, and an increasing growth rate is projected for capital investment. However, even at a reduced rate of growth, population size and density remain as primary forces driving national planning and resource allocation, serving to diminish the GDP and increase capital investment requirements. A continued high rate of population growth mitigate against environmental planning efforts, including ASLR response strategies. Table III-3 summarises the socio-economic conditions projected for 2022.

4.1.1 *Population Size and Distribution*

- Assuming constant rate of increase

Rapid population growth is by far the most influential factor in policy decisions relating to infrastructure investment and the provision of public services, such as education and health. A thirty year projection at the present growth rate would yield a national population of 175,708 by the year 2022, with a national population density of 2,510 people per square mile (OPS, 1991b).

The population growth rate for Majuro Atoll is significantly higher than that of the nation, at 6.3 % per annum as opposed to the national rate of 4.2%, although this may be high due to an undercount in the 1980 Census. A more accurate estimate is 5.0% per annum growth for Majuro 1980-88. When projected for thirty years, this growth rate puts Majuro's population at over 150,000 by the year 2022. However, a declining rate of growth is more likely, given recent government efforts which are expected to continue for the next several decades.

- Assuming declining rate of increase

Straight projections of the 1988 growth rate to the year 2022 do not take into account several factors which are expected to steadily decrease the growth rate over the next three decades. First, implementation of the National Population Policy and intensification of the Family Planning program in 1992 will have some effects. Second, migration, primarily to the United States under the Compact Agreement, is expected to grow (OPS, 1989b). Third, it is anticipated that the increased subsidies for copra begun in early 1992 will encourage people to remain on outer atolls. Finally, as population density reaches new extremes in Majuro, the atoll's desirability to potential migrants will decrease.

Taking these factors into account, a gradually diminishing rate of population growth is used to predict future population for Majuro atoll. A reasonable estimate is: annual growth at 5.0% for the period 1988-90, 4.2% for 1991-2000, 3.8% for 2001-2010, 3.6% for 2011-2020 and 3.4% for 2021-22.

These projections reflect several factors expected to come into play within the next thirty years. Initially, a large drop in annual growth rate from 5.0% to 4.2% would result from the doubling of the copra subsidy and the enforcement of the National Population Policy. The drop in growth rate between 1991-2000 and 2001-2010 reflects two trends. As the Compact of Free Association will expire in 2001, a certain number of people are expected to emigrate to the U.S. before this date. Second, implementation of the National Population Policy and increased family planning efforts are expected to be having greater effect by this time. The relative effect of these trends will diminish in following decades.

Based on population growth rate projections, a population of 73,500 people, with a density of 19,600 people per square mile, is estimated for Majuro Atoll for the year 2022. Economic development activities will affect population levels in any given Study Area.

4.1.2 Land use patterns and productivity levels

○ Higher density living

Land use patterns and productivity levels will be profoundly affected by projected population growth. It is estimated that an additional 2.2 square miles of land will be required to accommodate the population increase projected for Majuro by the year 2025 (OPS, 1991b). As Majuro Atoll consists of only 3.75 square miles, this means that nearly 90% of the land area will be necessary for housing needs in thirty years. Based on this, it is assumed that less land will be available for agriculture and that multi-level housing units may become common.

○ Decreasing Gross Domestic Product

If Majuro's GDP continues to grow at the national average of 5.9% per annum, it will reach \$ 380 million in the year 2022. Continued growth at this rate is unlikely unless sea bed mining becomes commercially feasible in the immediate future. This is unlikely and it is estimated that it will be approximately 25 years before sea bed mining becomes economically feasible (OPS, 1991b).

It is more likely that GDP growth rate will taper off as population increases and requires more expenditure for essential infrastructure and services, diminishing funds available to invest in the economy. Also, as GDP continues to grow, the same rate of increase represents a larger and larger amount, which becomes unrealistic. A more realistic GDP growth scenario is presented in Table IV-1.

4.1.3 Capital investment levels

The projected increase in population will greatly raise capital investment levels, as increased demand for government services will necessitate an expansion of infrastructure. Electricity generation will need to be increased from the present level of 38,000 MW per hour to 114,000 MW per hour by 2025 (OPS, 1991b). School and hospital facilities, as well as expanded sewerage and communications systems, will also be required to meet the needs of the expanded population. Increased demand for fresh water would necessitate the construction of a desalinization plant or a greatly expanded community water catchment surface, as the present system of collection, storage and distribution is already insufficient and water is frequently rationed.

Table IV-1: Projected growth of GDP (1988-2022)

Period (years)	Rate of Increase (%/annum)
1988-90	5.9
1991-95	5.0
1996-00	4.0
2001-05	3.0
2006-10	2.5
2011-15	2.0
2016-20	1.5
2021-22	1.0

Shoreline and fringing reefs, lagoon fringing reefs in particular, will feature significantly in increased infrastructure development. Increased commercial port facilities, including substantial shore area, will be required to handle the growth in shipping and imports needed for the population. The need for land to install government provided infrastructure (e.g. schools, communications facilities, hospitals, administration buildings, dumps) will result in the reef reclamation to create government land. Small marina and wharf facilities and private landowner landfills will continue to be developed on fringing reefs.

It is estimated that the capital value of physical infrastructure has increased by 7.5% per annum on Majuro from 1988-2000. This rate will likely increase to 10% during the period 2001-2010 and 12% during 2011-2022, primarily due to increased expenditure on capital developments to accommodate the need of a growing population. Under this rate of capital investment, the capital value of Majuro Atoll is expected to grow to \$ 3.03 billion by 2022.

4.1.4 Study Area population, GDP and capital value

○ Study Area 1

The population of Study Area 1 will reach 54,300 by 2022 under the scenario outlined. Approximately 130 acres of additional land would be needed to accommodate this population increase if current population patterns and housing customs are maintained. Space limitations are already critical in this area and without widespread landfilling or a shift to high- intensity, multi-floor housing units the area will not be able to accommodate the additional population. This will no doubt result in increased settlement of other areas on Majuro Atoll, including the other three Study Areas.

In Ebeye, Kwajalein Atoll, population growth severely dropped off when population density reached approximately 60,000 people per square mile, presumably because people no longer perceived it as a desirable place to live. As housing customs are the same in Majuro as in Ebeye, it is assumed similar conditions will operate. The population density of Study Area 1 is expected to reach 60,000 people per square mile in 2018, when population in the area hits 48,000. The population of the area will level off at that time and the 6,300 person increase projected between 2018-2022 will be absorbed by another part of the atoll, probably Laura.

Assuming that GDP and capital value increase as projected, the GDP of Study Area 1 would increase to \$ 116.7 million and the capital value would be \$ 2.73 billion by 2022.

○ Study Area 2

Laura represents the largest portion of relatively lightly populated land on Majuro and water and electricity are now readily available there. Population will likely surpass the projected 6,000 level and at least half of the land area will be used for housing. This change in land use patterns will diminish Laura's agricultural productivity, but may increase industrial productivity.

Based on projected GDP increases, GDP of the Laura area will reach \$ 12.5 million by 2022. As Study Area 1 reaches saturation point and more people choose to live at Laura, it can be expected that Laura will grow as a municipality, featuring businesses and improved education, health, and social services. Thus, the amount of increase in GDP will most likely be higher than the simple projection indicates.

Capital value of Study Area 2 is projected to increase to \$ 302.63 million by 2022.

○ Study Area 3

Since land area suitable for human settlement is extremely limited in Study Area 3, it is unlikely that population or land use will change substantially, although the western portion may possibly be used for residential construction.

A simple projection of the GDP of Study Area 3 in 2022 yields a GDP of \$18.5 million. As the nation continues to grow, the role of the international airport in development will be augmented, making the projected increase in productivity likely.

Capital value of Study Area 3 is projected to increase to \$ 150.6 million by 2022.

○ Study Area 4

Study Area 4 is unlikely to become a major population or development center by the year 2022. The islets in the area are very similar to other islets in the Marshall Islands which have been targeted for development of small-scale tourist resorts. A tourist resort, consisting of thirty individual bungalows and one central restaurant/services center, is hypothetically projected for Aneko island in the 2022 scenario. This will result in an additional 100 residents in that area, i.e. resort workers and their families. This makes a total population of 160 people, or a population density of 800 people per square mile for the Study Area in 2022.

Conservatively assuming that the units are rented for \$ 50 per night, and that they enjoy a 50% occupancy rate, rental revenues total \$ 275,000 per year. Together with revenues from scuba diving, deep sea fishing, entertainment shows, shuttle services and food, about \$ 750,000 would be generated by the facility. With a profit of 66% annually, the resort would augment the area's GDP by \$ 500,000. The current GDP projection yields \$ 151,700 for 2022. Adding the GDP generated by the resort, this results in a total GDP of \$ 651,700 for 2022.

Capital value of Study Area 4 is projected to increase to \$ 1.1 million dollars by the year 2022. This value reflects the estimated cost of establishing a small-scale tourist resort at Aneko islet.

4.2 Natural Developments

The growth of the population and economy of the Marshall Islands during the 30-year development scenario period will have significant effects on the natural systems of Majuro Atoll. The kinds of impacts will largely be those which have been occurring at an accelerating pace during the past 30 years. However, the increased population of Majuro and the availability of funds and technology will further accelerate the cumulative effects in the decades to come. The impacts will affect the terrestrial environment, including freshwater resources, and will likely be severe in the shoreline and marine environment.

4.2.1 *Terrestrial systems*

○ General

Terrestrial environments of Majuro Atoll will be heavily affected by the construction of infrastructure and dwellings for the growing population. The covering of the ground surface with impermeable structures will reduce groundwater lens recharge and thus impact freshwater resources, including the large lens in Study Area 2. Groundwater extraction will increase to maximum levels to provide whatever water possible from local sources to the population.

Pollutants and waste of all sorts will increase during the 30-year development scenario. In particular, the disposal of solid wastes on land will become an increasing problem and additional landfills will likely be created for this. Important terrestrial ecological sites, mainly the few remaining native forest areas and seabird sites on Majuro, will be under heavy pressure. Archeological, historic and cultural sites will also be threatened with disturbance, degradation or destruction if not specifically protected.

○ Study Areas

Study Area 1 will become completely urbanised, unless areas are specifically protected, eliminating whatever vestiges of the natural environment remain. This includes the only limited mangrove stand found on Majuro.

Study Area 2 will undergo the most substantial change during the 30-year development period, changing from totally rural agricultural zone to one at least partly urbanised. The groundwater resources will be extracted to the maximum extent possible to support the burgeoning population of Majuro and may suffer overextraction and salinisation. The agro-forestry areas of Laura will be replaced gradually with residential and perhaps light industrial development, with impacts for the groundwater recharge. Coconut crab will become very scarce and the historic/cultural sites along the lagoon shore will likely be disturbed by shoreline development if not protected.

The land area of Study Area 3 will be the least changed, as it already consists of the built-up airport and causeways. The long narrow land in the western portion of this Study Area may be altered for residential or other development.

The development of a tourist resort in Study Area 4 would result in significant changes to the natural systems in the development area. The native forest or coconut plantation and strand vegetation would be replaced with accommodation, infrastructure and support facilities, including dwellings for employees. Solid waste would be generated, and presumably disposed, in an area which has virtually none at present. The significant number of archeological sites found in the Study Area, as well as seabird sites, could be threatened by the development or overuse. On the other hand, tourism might result in the protection of these as visitor attractions.

4.2.2 Shoreline

○ General

Shoreline areas will continue to experience the natural cycles and patterns of erosion and accretion during the 30-year development scenario period. Erosion has been more evident in the recent past than accretion and has become critical in some areas, especially during extreme events. This may likely continue and the construction of shore protection structures is also very likely to continue, especially as more shoreline areas are developed. The shoreline will also be altered significantly by shore-based developments such as landfills, causeways, ports, marinas and wharves.

○ Study Areas

The shoreline of Study Area 1 is already highly altered. This trend will likely continue with the complete urbanisation of the area. It can be expected that most, if not all, of the natural shoreline in this area will be replaced by shore protection structures, landfill or some form of artificial shoreline.

Study Area 2 can expect to have a significant increase in shoreline development and reduction in natural shore as it changes from rural to residential and semi-urban. The dynamic nature of the shoreline will probably require that shoreline protection structures are installed in many areas during the 30-year period to 2022.

The shoreline of Study Area 3 is mostly artificial and will not change much during the development scenario period. If residential or other development is undertaken in the western area which is a yet unaltered along the shore, landfill and shore protection structures may be included.

Study Area 4 has unaltered shore areas which are highly dynamic due to the small size of the islets. The proposed tourism facility will result in changes to the shoreline of the development area. This may include: channel dredging, wharf construction and strand vegetation clearing. If beaches important to the tourist resort start to erode, sand retaining structures (e.g. groins) may be installed and shore protection may eventually be required. Otherwise shores of Study Area 4 would remain primarily in a natural state.

4.2.3 Marine

○ General

It is highly likely that reef reclamation and landfilling will accelerate during the 30-year development period to 2022. These developments will have major impacts on fringing reefs, completely obliterating reef flats. Off-site impacts include sedimentation during landfill construction and impacts from extraction of reef material for fill purposes. The land use to which the fill is placed (e.g. dump, residences, large buildings) will generate wastes which impact the adjacent marine environment.

More generally, Majuro lagoon waters will receive wastes from an increasing population, land based sources and development activities along additional portions of the surrounding land. The construction of additional causeways to link islets will further restrict circulation, reducing flushing and increasing exchange time; all with a negative effect on water quality. Construction materials will be in great demand on Majuro Atoll and it can be expected that dredging of lagoon sand or reef materials and quarrying of reef rock, with all the associated impacts, will expand.

The increase of Majuro's population will put increasing pressure on the reef fish and invertebrates harvested from the lagoon, reef and surrounding waters. Subsistence fishing pressure alone may result in serious over-fishing, while the development of commercial or sport fishing ventures will add to an already heavy, potentially unsustainable, harvest. If not better protected in the decades to come, marine turtles will become very scarce around Majuro Atoll. The exploitation of living resources will also be affected by the impacts on marine resource habitat described above.

○ Study Areas

The marine environment and resources surrounding Study Area 1 will experience the greatest level of disturbance, degradation and destruction during the 30-year period due to the high level of population growth. Nearshore resources will be particularly affected by shoreline development and extremely heavy fishing pressure.

The marine environment and resources of the other areas will be affected to a lesser degree depending on the level of population growth and the kind of shoreline development which occurs. In particular, Study Area 2 and the islet targeted for tourism development in Study Area 4 may experience a major increase in nearshore habitat degradation and exploitation of resources.

V Physical Changes and Natural System Responses

5.1 Assessment Of Physical Changes

5.1.1 Shoreline erosion

Shoreline erosion at Majuro Atoll is estimated using the Bruun rule of erosion (Brunn, 1988), the details of which are outlined in Annex 5. Shoreline retreat as the direct result of sea level rise is estimated using a generalized shoreline slope of 1/10 on both the ocean side and lagoon side. The additional shoreline retreat would thus be 10 feet and 33 feet for ASLR of 1 foot and 3.3 feet, respectively. Table V-1 presents estimated total shoreline retreat due to sea level rise. Table V-2 shows how much dry land is lost based on the shoreline retreat.

Table V-1: Estimates of shoreline retreat due to ASLR

	Shore Elevation (feet)	Water Depth (feet)	Sediment Deposit Width (feet)	Shoreline Retreat	
				ASLR=1	ASLR=3.3
Study Area 1:					
Ocean					
Jaroj-Wulka	8	2	700	80	260
Telap	8	2	300	40	130
Lagoon					
Jaroj-Wulka	6	28	750	30	110
Telap	6	28	400	20	70
Study Area 2:					
Ocean					
N-Section	10	2	1400	130	420
S-Section	10	2	500	50	170
Lagoon					
N-Section	6	28	370	20	70
S-Section	6	28	1250	50	150
Study Area 3:					
Ocean	8	2	350	50	150
Lagoon	6	14	400	30	100
Study Area 4:					
Ocean	8	2	700	80	250
Lagoon	6	14	430	40	130

The shoreline retreat with ASLR of 1 foot is from 40 to 130 feet on the ocean side of the Study Areas, and from 20 to 50 feet on the lagoon side. The corresponding dry land loss is 15 acres in Study Area 3 and as much as 50 acres in Study Area 1. With ASLR of 3.3 feet, the shoreline retreat ranges from 130 to 420 feet on the ocean side and from 70 to 150 feet on the lagoon side. The dry land loss ranges from 50 acres in Study Area 3 to 160 acres in Study Area 1.

These estimates are approximate, and are based on very generalized conditions. In reality, there are many variables, and prediction of the response to ASLR becomes much more difficult. Much site-specific research is needed to determine the extent of beach erosion that will result from ASLR.

5.1.2 Wave runup and flooding

Flooding of dry land area by ocean waters is a result of wave runup. The vertical height to which waves will run up on a shoreline slope determines the elevation over which inland flooding by waves will occur. The details for determining wave runup, and hence inundation limits, are outlined in Annex 4.

Table V-2: Estimates of dryland lost due to ASLR and erosion.

	Unprotected Shoreline (feet)	Present Dry Land (acres)	Dry Land Lost	
			ASLR=1 (acres)	ASLR=3.3 (acres)
Study Area 1:	44,000	510	50	160
Ocean	22,000		35	110
Lagoon	22,000		15	50
Study Area 2:	28,000	740	45	140
Ocean	16,000		35	110
Lagoon	12,000		10	30
Study Area 3:	16,000	230	15	50
Ocean	8,000		10	30
Lagoon	8,000		5	20
Study Area 4:	22,000	130	30	100
Ocean	11,000		20	75
Lagoon	11,000		10	25

Flooding by wave runup and overtopping is a constant threat in the Marshall Islands due to the low elevation of land areas. Even in the absence of ASLR, significant wave activity is generated by tropical cyclones, major storms and strong winds. Wave runup which overtops beach berms or protective structures and floods substantial land areas is not uncommon as a result of these events. When ASLR is added to the calculations, major inundation and flooding are predicted.

Tables V-3 and V-4 present wave runup elevation and distance inland for the ocean side and lagoon side of the Study Areas. These have been computed by adding significant wave runup to stillwater rise. When a substantial inundation distance is calculated or the stillwater level exceeds the beach crest, flooding is predicted (indicated by a code FL in the tables). The table shows that in many cases the significant wave runup nearly reaches the beach crest even during an annual event with ASLR=0.

These estimates should be considered conservative because even if the significant wave runup does not reach the top of the shoreline, the occasional, larger wave runup elevations could be expected to overtop the beach crest even during annual events. However, the calculated wave runup elevation assumes the natural topography of the shoreline and ignores the effects of building and other man-made structures. Where these occur, they would decrease the actual runup due to the blocking effect of the buildings.

Table V-3: Ocean side inundation limits (in feet, in reference to MSL)

Study Areas	Annual Extreme	50-Year Extreme	Typhoon Event
ASLR = 0 feet			
Wave Runup (Elev/Dist):			
Study Area 1:			
Jaroj-Wulka	7/80	9/90(FL)	FL(10.5/100)
Telap	7/80	9/90(FL)	FL
Telap Fuel Tanks	FL(13/380)	FL(13/500)	FL(13/550)
Study Area 2:			
N-Section	6/40	8/50	11/100(FL)
S-Section	7/60	9/90	FL(11/230)
Study Area 3:			
Causeways	6/170	8/180(FL)	FL
Islands	7/60	9.5/70	FL
Runway section	8/17	FL(9.5/26)	FL
Study Area 4	N/A	N/A	N/A
ASLR = 1.0 feet			
Wave Runup (Elev/Dist):			
Study Area 1:			
Jaroj-Wulka	8/90	9.5/100(FL)	FL
Telap	8/90	FL	FL
Terap Fuel Tanks	FL(13/400)	FL(13/540)	FL(13/560)
Study Area 2:			
N-Section	7.5/50	9.5/60	FL
S-Section	8/80	9.5/130	FL
Study Area 3:			
Causeways	7/175	FL(9/210)	FL
Islands	8.5/70	10/100(FL)	FL
Runway section	FL(9/22)	FL(10/33)	FL
Study Area 4	N/A	N/A	N/A
ASLR = 3.3 feet			
Wave Runup (Elev/Dist):			
Study Area 1:			
Jaroj-Wulka	FL(11/100)	FL	FL
Telap	FL	FL	FL
Telap Fuel Tanks	FL(13/560)	FL(13/570)	FL
Study Area 2:			
N-Section	11/70(FL)	FL(11/180)	FL
S-Section	10/200(FL)	FL	FL
Study Area 3:			
Causeways	FL	FL	FL
Islands	FL(10/200)	FL	FL
Runway section	FL	FL	FL
Study Area 4	N/A	N/A	N/A

Note: FL = Flooding; (FL) = Flooding in Partial Sections;
N/A = Not Available

Table V-4: Lagoon side inundation limits (in feet, in reference to MSL)

Study Areas	Annual Extreme	50-Year Extreme	Typhoon Event
ASLR = 0 feet			
Wave Runup (Elev/Dist):			
Study Area 1:			
Jaroj-Wulka	5/80	5.5/100(FL)	FL
Telap	5/80	5.5/140(FL)	FL
Telap Dock	8.5/0	9/20)	FL(10/220)
Study Area 2:			
N-Section	5/50	5.5/70	FL
S-Section	4.5/55	5/65	FL
Study Area 3:			
Causeways	5/7	5/8	FL(9.5/20)
Islands	4.5/35	5/40	9/70
Study Area 4	N/A	N/A	N/A
ASLR = 1.0 feet			
Wave Runup (Elev/Dist):			
Study Area 1:			
Jaroj-Wulka	6/130	6/240(FL)	FL
Telap	5.5/190	6/290(FL)	FL
Terap Dock	9/30	9/50	FL(11/300)
Study Area 2:			
N-Section	5.5/130	FL(5.5/350)	FL
S-Section	5.5/80	6/100	FL
Study Area 3:			
Causeways	6/9	7.5/11	FL(10/24)
Islands	6/45	6.5/50	9.5/90
Study Area 4	N/A	N/A	N/A
ASLR = 3.3 feet			
Wave Runup (Elev/Dist):			
Study Area 1:			
Jaroj-Wulka	FL(7/630)	FL(7.5/700)	FL
Telap	FL	FL	FL
Telap Dock	FL(9.5/110)	FL(9.5/150)	FL
Study Area 2:			
N-Section	FL	FL	FL
S-Section	8/170(FL)	8.5/190(FL)	FL
Study Area 3:			
Causeways	FL(9/20)	FL(9.5/21)	FL
Islands	8.5/65	9/75	FL
Study Area 4	N/A	N/A	N/A

Note: FL = Flooding; (FL) = Flooding in Partial Sections;
N/A = Not Available

It has been impossible to map inundation areas due to the lack of detailed topographic maps. Topographic maps with 1-foot contours are available for the D-U-D area (Study Area 1). However, inundation mapping of ASLR=1 and ASLR=3.3 was only possible on large scale maps. When reduced to page size, inundation lines were not distinguishable. However, estimates of flooding were calculated. Table V-5 shows the area that is expected to be flooded as a result of runup and overtopping during normal annual events and annual events combined with ASLR. Note that significant flooding is predicted by adding ASLR=3.3 to normal yearly runup events.

Table V-5: Flooding area estimates (acres) for annual event conditions.

Areas	Total Land (acres)	ASLR = 0	ASLR = 1	ASLR=3.3 (ft)
Study Area 1:	510			
Ocean		60	65	255
Lagoon		50	90	255
Study Area 2	740			
Ocean		20	25	50
Lagoon		15	30	50
Study Area 3:	230			
Ocean		10	65	115
Lagoon		10	10	115
Study Area 4:	130	N/A	N/A	N/A

Note: N/A = Not Available

5.1.3 Flooding frequency

Flooding frequency is estimated based on just two data points, plotting the predicted runup elevations for the 2-year and 50-year events on semi-logarithm graph paper. In the flooding frequency estimates, a flooding criterion is simply defined such that flooding occurs if the wave runup exceeds the typical "critical" beach crest elevation in the Study Areas. Tables V-6 and V-7 show the flooding frequency estimates on the ocean side and the lagoon side.

Table V-6: Ocean side predicted flooding frequency

	Critical Beach-Crest (times/yrs)	Flooding		Frequency
	Elevation (feet)	ASLR=0	ASLR=1	ASLR=3.3
Study Area 1:	7.5	1/30	1/5	>10/1
Study Area 2:	11	<1/100	<1/100	1/1
Study Area 3:	8	1/5	10/1	>10/1
Study Area 4:	N/A	N/A	N/A	N/A

Table V-7: Lagoon side predicted flooding frequency

	Critical Beach-Crest Elevation (feet)	Flooding Frequency (times/yrs)		
		ASLR=0	ASLR=1	ASLR=3.3
Study Area 1:	5.5	1/60	1/10	>1/1
Study Area 2:	5.5	1/60	1/5	5/1
Study Area 3:	7.5	<1/100	<1/100	>10/1
Study Area 4:	N/A	N/A	N/A	N/A

5.1.4 Water resources

ASLR may affect the loss of ground water resources in two ways. One is increased frequency of flooding due to storm high tides. Storm flood damage is not necessarily permanent, but it may make the ground water resource unusable at a critical time. The second threat is from island area loss, either by frequent tidal inundation of low-lying areas or by erosional loss of shoreline.

These impacts will affect all islets in all of the Study Areas, however, the only area for which detailed information is available is Study Area 2 (Laura). Miller and Mackenzie (1988) estimated a loss of ground water resources in Laura due to island area loss. Beginning with an initial island width of 1130 meters, loss of 150 meters from each shore is estimated as a response to the sea level rise of 1 meter by use of the Bruun rule. They calculate the original ground water lens cross-section area to be 14,000 m². After 1-meter sea level rise, they calculate the lens area of 7660 m². The reduction of the lens cross-section area is 45%. For the study model they use a lens boundary representing 50% saltwater content.

These procedures can be used to calculate reduction of the ground water lens caused by the reduction in land area presented in Table V-2. The shoreline retreat value for ASLR of 1 meter (3.3 feet) in Table V-1 is smaller than the value used by Miller and Mackenzie (1988) used. The calculation results are presented in Table V-8.

Table V-8: Reduction of fresh water lens cross-section area due to ASLR (Study area 2 - Laura)

ASLR (feet)	Shoreline Retreat (feet)	Island Width (feet)	Lens Height (feet)	Lens Depth (feet)	Lens Area (ft ²)
0	0	3700	2	81	150,000
1	200	3500	1.9	77	135,000
3.3	600	3100	1.7	69	105,000

5.2 Assessment Of Natural System Responses

It is impossible to assess the response of natural systems to ASLR physical changes in a precise manner for Majuro or the Study Areas. However, a general evaluation of the probable response of natural systems is possible.

5.2.1 Terrestrial

The major effect on natural systems by the physical changes predicted will be the loss of land. Land itself is an invaluable resource in the Marshall Islands, and particularly on Majuro. Otherwise, no unique or rare and endangered species of plants and animals will be lost by the reduction in land area. The remaining native forest and seabird sites of Majuro would be threatened by the physical changes of land loss and inundation.

Wave runup, overtopping and flooding will generally have major impacts on terrestrial vegetation and habitats of Majuro, however, none of these are unique to the island or country. ASLR will likely proceed with chronic erosion and minor inundation events, punctuated with major flooding and land loss during extreme events. Extreme events may result in long-term changes through extensive land loss and die-off of inundated vegetation. Reduction in the size of the fresh water lens will have potentially long-term impacts on vegetation and salinization of the groundwater lens could make it very difficult for major vegetation to become re-established.

5.2.2 Shoreline

The shoreline will undergo significant change due to wave runup and overtopping. Land loss due to ASLR and erosion have been described in detail in Section 5.1. Ecological values and biological communities of the shoreline will suffer major impacts as a result of these effects. Shoreline sediments and vegetation will adapt naturally to chronic erosion and limited inundation, as they do now. The wave action and erosion associated with extreme events will be the major forces affecting shorelines in conjunction with ASLR.

5.2.3 Marine

It is assumed that shallow nearshore marine communities will not be affected in a significant manner by ASLR itself. Coral reefs have a geologic record of adaptation to changes in sea level. A rising of sea may in fact enhance reef communities by allowing additional coral growth on the extensive reef flats which are currently exposed at low tides. The coral reefs of Majuro support habitats, plants and animals which are common to the whole country and probably the Central Pacific.

It is important to note that ASLR may be accompanied by other oceanographic change which make coral reef response unsure. The warming of water temperature beyond levels which corals can handle, the damaging effects of increased UV and the destruction by extreme events of increased intensity and frequency will have serious impacts on coral reefs and reduce their capacity to keep up with ASLR. In addition, coral reefs are subject to extensive human impacts, particularly reduced water quality and filling or extraction activities, which may reduce their ability to respond to ASLR.

VI Identification and Specification of Response Strategies

Potential response options to ASLR identified by the IPCC include protection, accommodation, retreat and no response. No response is a continuation of the present situation and actions, which includes ad hoc response to shoreline erosion and inundation. No single option will fully address the ASLR response planning needs of a country or island. A combination of response options will be required over different temporal and spatial patterns to adequately respond to ASLR and its effects.

In this Case Study, the technical and scientific aspects of each of the response options is initially examined in the general context of an atoll within a country of low elevation islands. Secondly, more specific examples of applying response strategies to the Study Areas on Majuro were developed.

There is need for a more detailed analysis and evaluation of the full range of alternative response options. The scope of this Case Study did not permit such a thorough examination of response strategies. However, even this preliminary investigation clearly demonstrates the need for a systematic consideration of response options and a clear ranking of the relative vulnerability of areas in order to mitigate ASLR.

6.1 Protection Strategy

6.1.1 *General considerations*

Atoll islets are primarily composed of unconsolidated coralline material and their shorelines require stabilization and protection against erosion by wave action which is expected to increase with ASLR. When wave runup exceeds the crest elevation of the foreshore land and ground elevation is lower than the wave runup height, wave overtopping and flooding of the backshore area occurs.

Protection against flooding damage by overtopping waves can be accomplished by: 1) improving the wave energy dissipating characteristics of the shoreline, 2) constructing adequate shore protection with a crest elevation above wave runup height, 3) constructing a wall or berm above the existing shoreline or shore protection crest to prevent overtopping during infrequent but severe storm wave attack, and/or 4) providing a scour-resistant surface behind the shoreline crest and grading the backshore for proper drainage during overtopping conditions.

Revetments, seawalls and bulkheads are commonly used shore protection structures placed parallel to the shoreline to separate the land area from the water. They protect only the land immediately behind the structure. When they are built on a receding shoreline, the recession will continue and may be accelerated on the adjacent shorelines. In addition, structures reflect wave energy that may cause erosion seaward of the structure. Vertical, smooth walls result in greater wave energy reflection and more scour. Coarse rubble slopes more effectively dissipate and absorb wave energy, reducing wave runup, overtopping and scour.

6.1.2 *Shoreline protection structural considerations*

The distinction between revetments, seawalls and bulkheads is primarily a matter of purpose. Revetments or seawalls protect the land from erosion and damage by wave action, while bulkheads are used to retain land.

A revetment is a shore facing of erosion-resistant material which protects a shoreline from direct erosion by waves. The most common method of revetment construction is an armor layer of stone or concrete units over an underlayer and bedding layer. The armor stones are sized according to the design wave. The underlayer and bedding layer distribute the weight of the armor layer and prevent loss of shoreline material through voids in the revetment.

A seawall protects the land from wave damage and are a long lasting, low maintenance shore protection method requiring limited shoreline space. The near vertical seaward face of seawalls deflects wave energy and can cause severe erosion and scour at the base of the wall. Undermining is one most common causes of seawall failure and failure of one section can often initiate failure of the entire wall. Because they dissipate little wave energy, smooth, vertical seawalls are more easily overtopped by waves than sloping irregular walls.

A bulkhead is a vertical wall constructed of sheet piles driven into the ground and stabilized by tie backs. The primary purpose of a bulkhead is to retain landfill in sheltered waters. The smooth vertical face does not absorb wave energy and is easily overtopped. Bulkheads are not appropriate for shore protection, and should be limited to use as retaining structures in harbors.

A detailed description of structural considerations for shoreline protection is found in Annex 7.

6.1.3 Shoreline protection design considerations

Revetment and seawall height are designed to prevent significant wave overtopping despite the water level rise and severity of wave attack. In some cases, however, it is not feasible and economically justifiable to construct a non-overtopping structure. It is important to insure that the foundation of any shore protection structure is adequate to protect against failure due to scour and undermining by wave action, particularly for seawalls. Ideally the shore protection should be constructed on solid, non-erodible substrata.

Shore protection designs for atolls are dependent on the availability of construction material. The first choice for revetment material is limestone, quarried directly out of the reef flat. Revetments can also be constructed with cast concrete armor units. Coral aggregate and sand for use in the concrete mix is readily available and can be obtained directly from the lagoon or old quarry sites. Unconsolidated sand and earth berms are effective against overtopping, but they are extremely vulnerable to erosion and scour during periods of high wave runup. A full discussion of design considerations for shoreline protection is found in Annex 7.

6.1.4 Coastal flood protection

When wave runup overtops the shore or shore protection structure, damage to the backshore immediately behind a shore protection structure can be reduced or eliminated by constructing a scour resistant surface of concrete, asphalt or stone. Coupled with a drainage system the scour protection can prevent the damage that could lead to significant damage to the structure itself.

Drainage control is also an effective means for reducing damage and flooding of the backshore area during overtopping conditions. Properly graded slopes and drainage channels can reduce the inundation limits and hasten the dewatering of flooded areas. Additional information on flooding protection structure and design considerations is found in Annex 7.

6.1.5 Berm elevation

Augmenting the height of natural beach berms may provide a short-term possibility for shore protection or be used in conjunction with structural shore protection. Material similar to that which makes up the atoll berms is available from the reef and lagoon. However, this material will be as erodible as the natural berms and will require regular, if not constant, replenishment from limited local sources.

6.2 Accommodation Strategy

The lack of naturally occurring high ground on low elevation islands reorients the use of accommodation as a strategy. Raising of existing structures on pilings, and planning new structures with raised first levels, would accommodate occasional flooding and help to minimize property damage during storms. Overall, though, it would be desirable to raise the general ground elevation of the atoll above the possible future still water level. To be effective, this should consider raising land elevation above the high storm condition still water levels, which will be at or near the existing land elevation under ASLR scenarios.

Raising and infilling land areas would best be carried out with construction of shoreline protection at the same time and location. Lagoon side reefs could be filled prior to protection, creating land which could be made available to migrants from other areas or islands affected by ASLR. The availability of suitable landfill material would likely be a constraint to large-scale land raising. Local reef and lagoon materials are appropriate for land raising, however the amounts available would be limited. Imported landfill material would be much more expensive. Other islets or islands which have been determined to be highly vulnerable and will be abandoned and lost to erosion and/or inundation should be considered as potential sources of fill for raising the elevation of other areas which are to be protected.

Accommodation strategies could also include adaptive economic activities for flooded areas, such as aquaculture or the culturing of halophytes. A heavier reliance on mariculture as a source of revenue is a possible means to offset economic losses associated with inundated coastal properties. Additional accommodation strategies which are not yet being thought about or seriously considered may become evident and viable in the future. For example, shallow lagoon areas may be appropriate for floating platforms for habitation, tourism or as a basis for other activities.

6.3 Retreat Strategy

Even on low elevation islands, different areas have different vulnerability to ASLR based on a number of factors, mainly geomorphologic. Areas which are less vulnerable, if identified, are areas to which retreat is possible. It is necessary to develop the means to identify which islands, or even which islets within an atoll, are more or less vulnerable to wave overtopping and flooding. With the identification of relative vulnerability, planned and precautionary retreat to less vulnerable areas is possible as a part of development planning and disaster response.

Retreat to naturally occurring higher ground is not possible on a low island, since there is no natural high ground of significant elevation. However, higher elevation areas could be created through a combination of installing shore protection and raising of land elevation, i.e. a combination of protection and accommodation strategies. These artificial high grounds should be created in areas which have been identified as naturally less vulnerable. Such areas could provide core zones among and within islands for retreat under extreme conditions, especially when coordinated with infrastructure development and disaster response planning.

The planning and development of safe core zones for retreat should include emergency warning and evacuation procedures for getting people to such areas during extreme events. In addition, structures, shelters and infrastructure should be designed and constructed to withstand extreme event conditions.

In sustained extreme conditions, and in the absence of creating higher ground which is habitable under extreme conditions, the only option may be to retreat completely. Abandonment, i.e. a population relocating to another island, is not unknown in the South Pacific. Atoll populations have historically moved to other atolls or to high islands as a result of drought, cyclone, tsunami or subsidence which have rendered the low elevation island uninhabitable.

Complete retreat from a country of low elevation islands to a foreign country requires addressing important issues such as the loss of the Marshallese culture and lifestyle, which are closely associated with the land and the ocean, and the loss of the sovereignty. Retreat from the Marshall Islands should be considered, evaluated and, if necessary, planned for as an appropriate response of last resort for the safety of the population.

6.4 No Response Strategy

Wave runup and overtopping of shorelines and shore structures by waves, leading to frequent flooding is already a severe problem and a threat to existing social, economic and political institutions. Passive coastal management, i.e. avoiding development in immediate shoreline areas without assessing relative vulnerability, would be ineffective as the threat of flooding is similar for all areas due to the nearly uniform low elevation of the island land mass.

A no response strategy would be a continuation of the ad hoc and crisis response measures now being used to address erosion and flooding problems in more valuable or densely populated areas. For outer islands, and islets with low population, no action in response to the threat of wave overtopping and flooding would generally be a continuation of the status quo due to the lack of resources for coastal management, shoreline protection and disaster response planning.

6.5 Specification Of Responses

6.5.1 Protection

○ Protection conditions for Majuro Atoll

The annual wave event for ASLR=1 and ASLR=3.3 and the 50-year and typhoon event waves for ASLR=1 were used to determine shore protection needs for Majuro Atoll. ASLR=3.3, when combined with the 50-year and typhoon wave conditions, results in a water level exceeding most of the land elevation of Majuro and specifics of protecting Majuro from such excessive water level rise were not calculated.

The design wave heights calculated for the Study Areas are shown in Table VI-1. A major difference in wave height is shown for different portions of the ocean shore in the study areas, demonstrating how difficult it is to make design and cost projections with the limited amount of information which is available.

Table VI-1: Design wave heights at shore (ft)

	Annual Wave Event			ASLR=1 w/ Storms	
	ASLR=0	ASLR=1	ASLR=3.3	50-year	Typhoon
Study Area 1					
Ocean	3	3	5	4	6
Fuel Tank Area (Ocean)	17	17	19	18	20
Lagoon	3	4	6	5	7
Study Area 2					
Ocean	3	3	5	4	6
Lagoon	2	2	4	3	5
Study Area 3					
Ocean	3	4	5	5	6
Lagoon	2	2	3	3	5
Study Area 4					
Ocean	2	3	4	3	5
Lagoon	2	2	3	3	5

Table VI-2 gives generalized revetment elevations based on calculated wave runup using the design wave heights in Table VI- 1. The structure crest elevations may allow some wave overtopping, but are high enough to prevent wave overtopping from resulting in significant inland flooding. The table shows that storm conditions coupled with ASLR=1 require structure heights similar to those required for ASLR=3.3 under annual conditions.

Table VI-2: Generalised revetment crest elevations (ft above MSL) versus ASLR and wave conditions.

(a) Annual Event

	ASLR=0			ASLR=1			ASLR=3.3		
	BK	RP	ST	BK	RP	ST	BK	RP	ST
Ocean	9	8	-	10	9	9	-	13	12
Telap Fuel Tanks (Ocean)	-	-	15	-	-	16	-	-	20
Lagoon	8	7	-	9	9	-	-	13	12

(b) ASLR=1

	Storm Conditions					
	50-year			Typhoon		
	BK	RP	ST	BK	RP	ST
Ocean	-	11	10	-	-	14
Telap Fuel Tanks (Ocean)	-	-	18	-	-	22
Lagoon	-	10	9	-	-	14

Notes: '-' = Not applicable
 BK = Concrete block, rubble or cube revetment
 RP = Graded riprap revetment
 ST = Quarrystone or concrete tribar or cube armor revetment

○ Protection costs for Majuro

Shore protection costs for Majuro are based on design conditions for Kwajalein Atoll, where a major study on shore protection was undertaken (Sea Engineering Inc. and R. M. Towhill Corp., 1988) as the design conditions for Majuro are similar. The construction costs are based on general revetment cross-section designs, which were sized to typify average design conditions at Kwajalein Atoll in the Marshall Islands and these are generally applicable to Majuro also, at least for preliminary cost estimating purposes.

In the Kwajalein Atoll study, comparison was made of the first cost of construction and future maintenance costs versus increasing storm wave intensity and design wave heights. Table VI-3 shows the design wave height, water depth, and structure crest elevation used for the model designs.

Table VI-3: Estimate used to determine three model designs to protect Kwajalein Atoll.

	Case 1	Case 2	Case 3
Typical water depth below MSL at structure toe (ft)	1	1	1
Design wave height (ft)			
Ocean	3	3	6
Lagoon	3	4	7
Crest elevation of model structures above MSL (ft)	6	7	12.5

The strength of the Case 1 design revetment is most likely exceeded during the life cycle. Complete replacement of the armor layer may be required during the revetment life. The Case 2 design revetment has a chance to be exceeded by a storm during the 25-year cycle. However, the design strength is not expected to be exceeded significantly, and damage should be small. For the Case 3 design revetment, the probability of the design strength being exceeded in the 25-year life cycle is very low, and maintenance cost is expected to be zero.

The costs for shore protection at Kwajalein are summarized in Table VI-4 for two categories: shore protection for Kwajalein and Roi-Namur Islands and for outer islands. Kwajalein Island and Roi-Namur have on-site construction and maintenance capabilities, but the outer islands are remote and require transportation of materials, equipment and personnel by boat. The total shore protection cost is for 100-foot unit structure lengths, including the construction cost and the maintenance cost for a 25-year life cycle, and are based on data obtained from the Pacific Ocean Division, Army Corps of Engineers, reflecting the construction cost experience for Kwajalein as of January 1988.

Shore protection costs for Majuro Atoll can be estimated based on the data given in Table VI-1 as the design wave heights at the shore for Majuro Atoll are within the range of wave heights used for the cost estimates in Table VI-4. A typical water depth at the structure toe at Majuro Atoll is also considered one foot below MSL similar to that at Kwajalein. Shore protection structures are selected for Majuro Atoll according to the design wave conditions, as presented in Table VI-5.

Table VI-4: Kwajalein Atoll shore protection costs (US \$) per 100 feet for 25-year life cycle, as of Jan. 1988. (Sea Engineering and R.M. Towill Corporation, 1988)

(a) Kwajalein and Roi Namur Islands

Shore Protection Type	Construction Cost	Maintenance Cost	Total Cost
Case 1			
Riprap	20,350	20,350 (100%)	40,700
Concrete Block	108,400	108,400 (100%)	216,800
Concrete Rubble	56,450	112,900 (200%)	169,350
Case 2			
Armor Stone	45,450	6,820 (15%)	52,270
Concrete Cubes	159,600	23,940 (15%)	183,540
Riprap	47,500	7,130 (15%)	54,630
Case 3			
Armor Stone	127,350	0 (0%)	127,350
Tribar	134,100	0 (0%)	134,100
Concrete Cubes	236,350	0 (0%)	236,350

(b) Outer Islands

Shore Protection Type	Construction Cost	Maintenance Cost	Total Cost
Case 1			
Riprap	115,100	115,100 (100%)	230,200
Concrete Block	193,950	193,950 (100%)	387,900
Concrete Rubble	139,100	278,200 (200%)	417,300
Case 2			
Armor Stone	210,400	31,560 (15%)	241,960
Concrete Cubes	336,650	50,500 (15%)	387,150
Riprap	215,300	32,300 (15%)	247,600
Case 3			
Armor Stone	423,300	0 (0%)	423,300
Tribar	313,900	0 (0%)	313,900
Concrete Cubes	478,950	0 (0%)	478,950

Shore protection costs are estimated by adjusting the selected case number cost in Table VI-3 to the structure height difference and to a cost increase. A cost increase of 15 percent is used for the four year period from 1988 to 1992. Table IV-6 gives the shore protection cost estimates for Majuro Atoll per 100-foot shoreline length. Study Areas 1, 2 and 3 are considered to have on-site construction and maintenance capabilities. Study Area 4 is categorized to be outer islands. The cost estimates include both construction costs and 25-year life cycle maintenance costs. However, protection against higher sea level does not always result in greater costs, as shown in the table.

There is considerable increase in cost when on-site capabilities are not possible. The choice and availability of materials also greatly alters cost estimates, with riprap and armour stone the least expensive. Riprap revetments, while cost-effective, may not be sufficiently large to withstand the extreme design waves because the size of the rocks which could be quarried from Majuro reefs. Thus, security of those areas protected with riprap may not be assured and maintenance costs would be quite high, as major storms would be likely to damage sections.

With sufficient financial resources and construction materials, shore protection of any part of Majuro is feasible under the ASLR conditions examined in Table VI-6. Applying this information to examples in the Study Areas allows more detailed technical and cost evaluations to be made.

Table VI-5: Selected revetment types versus wave conditions.

	Annual Event						ASLR = 1 foot								
	ASLR Conditions in Feet						Storm Conditions								
	ASLR=0		ASLR=1		ASLR=3.3		50-year			Typhoon					
	BKRP	ST	BK	RPST	BKRP	ST	BKRPST	BK	RPST	BK	RPST				
Study Area 1:															
Ocean	X	X	-	X	X	-	-	X	-	X	X	-	-	X	
Fuel Tank Area (Ocean)	-	-	X	-	-	X	-	-	X	-	-	X	-	-	X
Lagoon	X	X	-	-	X	X	-	-	X	-	-	X	-	-	X
Study Area 2:															
Ocean	X	X	-	X	X	-	-	X	X	-	X	X	-	-	X
Lagoon	X	X	-	X	X	-	-	X	X	X	X	-	-	-	X
Study Area 3:															
Ocean	X	X	-	-	X	X	-	-	X	-	-	X	-	-	X
Lagoon	X	X	-	X	X	-	X	X	-	X	X	-	-	-	X
Study Area 4:															
Ocean	X	X	-	X	X	-	-	X	X	X	X	-	-	-	X
Lagoon	X	X	-	X	X	-	X	X	-	X	X	-	-	-	X

Notes: 'X' = Selected

'-' = Not selected

BK = Concrete block, concrete rubble or concrete cube revetment

RP = Graded riprap revetment

ST = Quarystone, concrete tribar or concrete cube armor revetment

Table VI-6: Majuro shore protection cost estimates (thousand US \$) per 100 feet for 25-year life cycle

(a) Study Areas 1, 2 and 3

Shore protection type	Annual Event			ASLR=1 w/ storms	
	ASLR=0	ASLR=1	ASLR=3.3	50-year	Typhoon
Ocean Side					
Riprap	60	79	110	94	-
Concrete Block	356	-	-	-	-
Concrete Rubble	278	-	-	-	-
Armor Stone	-	75	140	83	146
Concrete Cubes	-	290	262	317	302
Tribar	-	-	148	-	171
Lagoon Side					
Riprap	54	79	110	87	-
Concrete Block	320	-	-	-	-
Concrete Rubble	250	-	-	-	-
Armor Stone	-	68	140	75	146
Concrete Cubes	-	264	262	264	302
Tribar	-	-	148	-	171

(b) Study Area 4

Shore protection type	Annual Event			ASLR=1 w/ storms	
	ASLR=0	ASLR=1	ASLR=3.3	50-year	Typhoon
Ocean Side					
Riprap	341	356	499	427	-
Concrete Block	637	-	-	-	-
Concrete Rubble	685	-	-	-	-
Armor Stone	-	348	468	383	541
Concrete Cubes	-	612	531	612	612
Tribar	-	-	347	-	401
Lagoon Side					
Riprap	303	356	499	392	-
Concrete Block	573	-	-	-	-
Concrete Rubble	617	-	-	-	-
Armor Stone	-	313	468	348	541
Concrete Cubes	-	556	531	556	612
Tribar	-	-	347	-	401

○ Protection of specific areas

In the short-term full protection will likely be considered as appropriate initially for Study Areas 1 and 3 and this is further developed here as a realistic example of protection costs. In Study Area 1 the entire shoreline would be protected, and in Study Area 3 at least the shoreline along the airport would be protected.

Table VI-6 gives cost estimates for shore protection for the entire shoreline in Study Area 1 based on information presented in Tables VI-1, VI-2, VI-5 and VI-6. For the airport in Study Area 2, protection costs are based on crest elevations in Table VI-2 and the cost of additional armour material to be placed over the existing revetment. The table gives shore protection cost estimates for three cases: 1) ASLR=1 and the typhoon wave, 2) ASLR=1 and the 50-year wave, and 3) ASLR=3.3 and the annual wave. The shore protection costs given in Table VI-7 are for shore protection structures only, and they do not include the cost of land-fill material to elevate the Study Area.

6.5.2 Accommodation

As with protection, accommodation is possible for any of the Study Areas with sufficient financial resources, technical expertise, technology and materials. The application of accommodation strategies would probably commence with the raising of structures on stilts or pilings. This would most likely be applied initially in those areas with large numbers of important buildings at risk, notably ocean shoreline buildings in Study Area 1. A detailed analysis of the technical and financial aspects of raising buildings was not possible as part of this study.

The raising of land elevation by putting in fill material could be considered as a possible response for any of the Study Areas. Realistically, as with protection, it would initially be applied to areas of high value and high population density. Detailed study of relative vulnerability is required in order to target land raising to those areas least susceptible already to overtopping and inundation.

Table VI-7: Cost estimates (Millions US \$) for shore protection: Study Areas 1 and 3.

(a) ASLR=1 and the Typhoon Event

Protected Area	Shoreline Length (feet)	Type of Structure Material	
		Armor Stone (mill. US\$)	Tribar (mill.US\$)
Jaroj-Wulka-Telap	58,000	105	100
Airport	18,000	22	25
Total		127	125

(b) ASLR=1 and the 50-year Event

Protected Area	Shoreline Length (feet)	Type of Structure Material	
		Armor Stone (mill. US\$)	Riprap (mill.US\$)
Jaroj-Wulka-Telap	58,000	46	52
Airport	18,000	6	8
Total		54	60

(c) ASLR=3.3 and the Annual Event

Protected Area	Shoreline Length (feet)	Type of Structure Material		
		Armor Stone (mill. US\$)	Tribar (mill.US\$)	Riprap (mill.US\$)
Jaroj-Wulka-Telap	58,000	81	86	64
Airport	18,000	20	22	10
Total		101	108	74

The availability and cost of landfill materials would be a major consideration for large-scale raising of land elevation. For example, locally available landfill material cost is \$15/cu yd (Feb. 1992), but the local supply is very limited. It is estimated that landfill material would have to be imported even just to elevate the entire Study Area 1. The imported material would be much more expensive.

The cost to raise by one meter or yard the land elevation of Study Area 1, which is less than one square mile in area, would be approximately \$ 40-50 million. Raising land elevation would entail additional costs of temporarily moving buildings or rebuilding structures which are demolished to make way for substantial land filling. Roads and other infrastructure would obviously be elevated as well, requiring considerable planning and capital outlay. A decision to proceed with major landfilling as a response strategy would require advance planning for future infrastructure development, land use planning and development to avoid inappropriate development and expenditure.

In advance of major accommodation response in less valued (i.e. less populated) areas, interim accommodation measures are possible through coastal planning and land use management. For example, in Study Area 2, drainage patterns and coastal construction could be managed to minimize coastal erosion. A combination of accommodation and protection is likely for most of the high value areas of Majuro, as is already being undertaken on an ad hoc basis in response to current conditions and flooding events.

Developing and implementing an interim programme of accommodation response would entail additional costs and need to include a significant public education aspect. Accommodation of this sort would probably be accomplished through land use planning, zoning and construction codes. These forms of land use and construction control do not currently exist in the Marshall Islands. It may be possible to apply these kinds of regulation to government construction and land use in the short-term. It will likely take much longer to create an informed public which is ready to accept the regulation of private development and housing construction and the enforcement of land use planning and zoning controls.

Until an informed and aware public is ready to accept and support such regulatory developments, it is not likely that the legal basis for the controls will be enacted. Without the legislation to develop and implement land use planning, zoning and construction codes, it will not be possible to develop an accommodation response strategy. These needs will no doubt force a difficult debate on land tenure reform and other fundamental challenges to the traditional way of life and concepts of land and resource control.

6.5.3 Retreat

The lack of land with significant elevation on Majuro Atoll or in the Marshall Islands, changes considerably the conventional notion of retreat, i.e. moving gradually back to higher ground while natural forces are allowed to take their course in the coastal zone. Retreat responses for Majuro will require the identification of which portions of the atoll are less vulnerable than others. It is beyond the scope of this study to identify these areas. A programme to obtain the information for detailed vulnerability analysis will need to be designed, including the technical specifications and detailed costs required to undertake such analyses. With detailed vulnerability information, it should be possible to indicate areas which are less likely to be inundated as appropriate for retreat.

This kind of information will allow strategic, precautionary ASLR retreat planning to be undertaken. This planning should be coupled with development planning and the land use planning and zoning actions outlined as part of accommodation. In addition, detailed vulnerability analyses, when combined with improved meteorological and oceanographic information and disaster warning systems, will become an invaluable component of disaster response and evacuation plans.

Least vulnerable sites should be selected for the development of infrastructure and public facilities, e.g. schools, hospitals, telecommunications and airstrips, which are essential during natural disasters, including ASLR. Structures and facilities should be built to extreme event design criteria and include consideration of their use during disasters, e.g. as evacuation centers and temporary shelters. Based on detailed vulnerability analysis, a network of such areas should be established on Majuro Atoll and all outer islands.

In addition to least vulnerable areas, detailed vulnerability analysis will also identify most vulnerable areas. This information will also become an essential part of disaster response and strategic climate change response planning. Those areas most likely to be inundated can be identified, allowing development to be directed away from these areas. The displacement of the population at risk and the replacement of the structures and infrastructure to another area can be planned for.

If worst scenario predictions of ASLR begin to appear, then strategic retreat to these previously identified areas of least vulnerability will be necessary. In such a case, retreat will likely come about in phases, as different areas are affected by natural disasters exacerbated by ASLR and climate change. Retreat may take the form of Marshallese moving to least vulnerable areas within or among atolls in the country, with Majuro Atoll being developed as the ultimate safe haven for the nation. Within Majuro Atoll, the protection of the major existing infrastructure, telecommunications, airport, housing areas, water supply and other important facilities will thus be critical for the development of the retreat option for Majuro itself, as well as for the entire country.

Full retreat of the entire population of Majuro Atoll and the Marshall Islands must be considered in planning for worst case ASLR and climate change scenarios. This is obviously beyond the scope of this Case Study and will require international consideration and planning. If necessitated by worsening conditions, in 2022 this would entail the movement of more than 73,000 people from Majuro and 165,000 for the entire country.

6.5.4 No response

Land is already a precious resource in Majuro, as in the rest of the Marshall Islands. With projected population growth land will be even more scarce a commodity. It is difficult to imagine that there will be no response to the existing situation which already requires a planned, coordinated response to address wave runup, overtopping and flooding events, with or without ASLR. The lack of resources to draft and implement a Coastal Zone Management plan hinder this development.

For the four Study Areas evaluated, no response will result in the loss of considerable land due to erosion and ASLR. As shown in Table V-2, this will be between 140 and 450 acres of land, representing 8.6 % to 28 % of the total land area of the Study Areas. Significant inundation and flooding will occur even just when annual extreme events are considered in conjunction with ASLR, as outlined in Table V-5. Under ASLR=0 conditions, 165 acres (9.8%) of total land in the Study Areas would be inundated and under ASLR=3.3 conditions the entire atoll would be flooded.

The no response option would result in retreat, either strategic or disaster response retreat, and eventually lead to complete retreat (i.e. abandonment) under worst case scenarios due to land loss and flooding. The no response option may appear to be the only option for relatively sparsely inhabited small islets with very little land resources or infrastructure, such as those islands located in Study Area 4. These are representative of the outer islands in the Marshall Islands and response measures would require relatively large economic and institutional resources. The importance of land areas, even small islets, in future population and development scenarios may be such that response is warranted.

6.6 Response Impacts On Natural Systems

6.6.1 Protection

Implementing a protection response strategy would protect the land from loss by erosion and protect the human and natural values of the land area from inundation and flooding. The amount of land which would be protected is significant. From Table V-2, it can be seen that the estimate of dry land lost for Study Area 1 is 50 acres (10%) under ASLR=1 and 160 acres (22%) under ASLR=3.3. For Study Area 3, the loss would be 15 acres (6.5%) under ASLR=1 and (22%) under ASLR=3.3. The costs for protecting a total of 65 acres under ASLR=1 is estimated at \$ 54 million, while the cost of protecting 210 acres under ASLR=3.3 is \$ 127 million. In addition, the construction of shore protection structures would possibly result in the creation of additional land through the filling of areas behind the structures, although this has not been estimated.

Implementing a protection strategy will have negative effects on the natural systems of Majuro. These should be evaluated through Environmental Impact Assessment and the impacts avoided or mitigated as much as possible. The construction of shore protection structures will effectively alter the shoreline from a sediment coast of reef-derived sand, rubble and blocks to a rocky coast of revetment or seawalls. Shore protection structures already cover a significant portion of the Majuro coast and there appear to be no major environmental impacts from these.

The atoll shoreline is not a particularly biologically productive or unique ecological area. Its replacement by rock or concrete structures will not drastically change the overall ecological value of the shoreline. Ecological processes, notably nearshore sediment dynamics and wave effects, will be highly altered by the structures. However, it is assumed that sediment loss and wave overwash are the reason for constructing the structures and therefore a reduction in these would be considered acceptable.

Coral reefs immediately adjacent to the shoreline structures will probably not be significantly adversely affected if the structures are designed and constructed using well-known methods to minimise environmental impacts, particularly impacts from increased sediment load. Terrestrial habitats landward of the structures would benefit from protection from land loss and inundation.

If local material is used to construct shoreline protection structures, considerable impacts may result. Removal of reef quarry stone from reef flats can result in increased shoreline erosion. However, environmentally sound design and operation can actually create marine habitat on reef flats otherwise exposed at low tide. Dredging of lagoon sand and gravel for concrete also has potential environmental impacts, particularly due to direct habitat disturbance or destruction and suspended sediments. These impacts can be avoided or reduced through known planning and operations methods. All local materials are limited in extent and their extraction will have some impacts, especially if undertaken to excessive levels.

Covering backshore areas with impermeable material to reduce erosion behind protection structures and facilitate drainage will replace the natural vegetation in these areas. However, reducing the amount of salt water which enters soils and groundwater during inundation will probably benefit vegetation in adjacent areas. If the height of beach berms is to be raised by using sand, gravel or block obtained from the reef or lagoon, the potential impacts described above for dredging and quarrying will have to be taken into account. If materials for shore protection structures are imported, it must be recognised that the extraction, transport and deposition of these materials will also engender impacts.

6.6.2 Accommodation

The raising of land elevation to accommodate ASLR would probably be undertaken with shore protection in the same location. The impacts associated with shoreline structures, as outlined above, should be taken into consideration. There would be obvious change to terrestrial vegetation and habitat. However, atoll vegetation communities adapt to land-building and readily colonise natural shore deposits or land fills.

The lack of unique or endemic species reduces the possibility of adverse impacts to the overall biodiversity of the Marshall Islands. Particular attention would have to be given for some special areas, e.g. remaining native forest and sea bird nesting and breeding areas.

If the extraction of local reef and lagoon materials or other islets is to provide the fill for raising land elevation, appropriate environmental planning and management of dredging and quarrying is essential. Imported materials will also result in impacts at the place of their removal and in transport and deposition.

6.6.3 Retreat

Retreat responses which involve the protection and building up of less vulnerable areas as safe haven areas will involve the same impacts as shore protection and land raising. A response strategy of total retreat, i.e. abandonment, will not lead to impacts on natural systems other than those resulting from ASLR and natural processes.

6.6.4 No response

With no response to ASLR, erosion and flooding will have considerable impacts, especially on shoreline and terrestrial systems. Chronic and large episodic erosion events will result in the loss of land and terrestrial habitat. Ad hoc landfill and shore protection efforts will likely continue, with their associated impacts which are not always subject to Environmental Impact Assessment. Innundation will also affect terrestrial vegetation and groundwater. Impacts from unplanned response to erosion and flooding will likely be greater than a planned response that takes into account environmental aspects of response measures.

VII Vulnerability Analysis

7.1 Impacts On Socio-Economic And Ecological System

7.1.1 Socio-economic impacts

The projected protection, accommodation and retreat responses to ASLR will have pronounced socio-economic implications and will precipitate social and economic change because Marshallese lifestyle is so closely associated with near-shore and coastal zone areas and resources. Changes in water resources, food security, living conditions, lifestyle and economic opportunity would be expected.

○ Economic impacts

Major economic impacts can be expected from the implementation of the protection, accommodation and retreat response strategies outlined, but a detailed examination of these is outside the scope of this Case Study. A protection strategy in particular, will entail significant economic commitment to implement. For example, the estimates calculated for protection of Study Areas 1 and 3 indicate that \$ 127 million will be required to protect these areas from a typhoon under ASLR=1 conditions. Under ASLR=3.3 conditions, this level of protection would be insufficient over a 50 year time frame. Additional response action, such as raising the land elevation would probably add another \$ 50 million to the response costs making a total of over \$ 175 million for protecting two Study Areas.

This cost for protecting a relatively small portion of the Marshall Islands is more than 4 times the current GDP. It is evident that a protection and accommodation programme for these Study Areas would have to be spread out over many years, due to the limited economic capability of the Marshall Islands. Even if spread out over 30 years, this would be a cost of \$ 6 million per year, a considerable burden, and probably prohibitive, for the Marshall Islands economy. Assistance to undertake response strategy planning and implementation, particularly the implementation of major protection actions, will likely be required from outside the Marshall Islands. Increased external assistance, however, also has impacts on the local economy.

Other aspects of ASLR will engender further costs. Fresh water resources will be greatly reduced, as a result of salinization of the Laura fresh water lens. Majuro would be forced to pursue costly options to provide adequate water supply to its growing population. Options could include: 1) building a desalination plant, 2) building an Ocean Thermal Energy Conversion (OTEC) Plant, or 3) constructing large floating water catchments to place in the lagoon to catch rainwater.

Overall, extensive economic impacts are expected from developing and implementing ASLR response plans. In a small country such as the Marshall Islands, made up entirely of low elevation islands, the whole economy must be taken into consideration when evaluating the impacts of response planning.

○ Social impacts

Population growth in the Marshall Islands and Majuro Atoll in particular, together with a shrinking land mass due to ASLR, will greatly increase population density. Urban Majuro already features one of the highest population densities in the world. This has led to overcrowding, unemployment and a breakdown of traditional lifestyle, all of which contribute to social disorder, resulting in an increasing crime rate.

Marshallese lifestyle is closely linked to the limited land area and nearshore marine resources. Further crowding of the population into protected or less vulnerable areas will necessitate reform of the land tenure system, the backbone of the Marshallese social structure. Marshallese lifestyle involves a one-story dwelling which shelters the extended family. The cultivation of local foods, including yams, taro, bananas, and coconuts is undertaken on family land. If population is concentrated into protected and less vulnerable areas, it will be impossible to accommodate these aspects of the Marshallese lifestyle. The construction of shore protection structures will also block or impede access to the ocean for canoes and fishermen.

The loss of arable land and resulting increased reliance on imported foods can be expected to grow as sea level rises. The Marshall Islands imports the majority of its foodstuffs, with over 40% of GDP going to their purchase. Urbanization and the reliance on foreign aid have undermined the traditional subsistence system, especially on Majuro. Different segments of Marshallese society will be affected in different ways by the response strategies and the entire range of Marshall Island societal strata will need to be considered in fully evaluating the social impacts of responding to ASLR.

7.2 Institutional Implications Of Response Options

Existing institutions for environmental management are inadequate for planning and implementation of adaptive responses to ASLR. Strengthening of the Environmental Protection Authority, the Office of Planning and Statistics and the Marine Resources Authority will be necessary to cope with expected coastal and nearshore changes. The National Disaster Committee, which regularly meets when storms are in the area, is already well organized, and will have to be expanded to assist in response to ASLR

The National Environmental Management Strategy has identified a number of institutional deficiencies which must be addressed if environmental management and planning, including what is required to address ASLR, are to improve. The main problems include the need for improved Environmental Impact Assessment, the need for zoning and building standards, better coordination between development and environmental management activities and the difficulties in adapting the traditional land tenure system to western style management efforts. Planning and implementing a response to ASLR will be improved by addressing these institutional needs which are already required in order to improve current environmental management and planning problems.

Other legal and institutional implications result from developing and implementing response strategies:

○ Challenge to sovereignty

The potential for loss of sovereignty associated with the extreme case of total retreat (abandonment) is of deep concern to the Marshall Islands. A recent survey of Marshallese leaders indicated that a guarantee of sovereignty would be necessary before they would willfully relocate to a foreign nation. Considering the response options possible, it is unlikely that total abandonment will take place under an ASLR=1 scenario and a continued commitment to protect land against erosion. However, under ASLR=3.3 conditions, especially when coupled with extreme events, major relocation of population could become a possibility. The issue of sovereignty should thus be fully considered when evaluating response scenarios and plans.

○ Reform of land tenure system

As 100% of the land in the Marshall Islands is privately held and the government does not have authority to utilize the land without the owner's consent, new legal arrangements will be needed to allow the government to implement response options, e.g. it may be necessary to establish public easements along the coastline. The concentration of the entire population in protected or less vulnerable areas may force fundamental land reforms. For example, the relocation of displaced inhabitants from outer islands into the protected areas and the creation of land by filling in reef flats on the lagoon side will result in land and migration issues in a manner and at scale not yet experienced.

○ Implementation of Coast Conservation Act 1988

A comprehensive CZM plan created under the Coast Conservation Act, 1988 and long term technical assistance to develop and implement such a plan are needed to integrate the ASLR response planning into the broader context of coastal planning and resource management considerations.

○ Shrinking of Exclusive Economic Zone

The potential for loss of maritime boundary base points, and consequently the loss of area in the Exclusive Economic Zone, is of great concern. A nation composed of over 99% water, the Marshall Islands is increasingly looking to its pelagic marine resources and the deep sea bed. The potential for submersion of one or more of the atolls, and the consequent loss of claim to pelagic and deep sea resources, would economically disadvantage the Marshall Islands. Development of response options need to consider how to address this issue in the international arena.

○ Coordination of Institutional Response

The coordination of studies on ASLR, and the implementation of response strategies requires inter-agency effort at the policy-maker level. The Task Force on EMSD should be expanded to oversee programs related to ASLR, and climate change, as is called for in the National Environmental Management Strategy, 1992-96.

VIII Evaluation and Interpretation

8.1 Vulnerability Profile Evaluation And Priority Setting

The analysis of the vulnerability of four Case Study Areas on Majuro to ASLR and extreme events reveals that all land areas are highly vulnerable to major physical impacts, i.e. wave overtopping and flooding. These impacts are severe under ASLR=1 when combined with 50 year and typhoon conditions and under ASLR=3.3 under normal weather conditions. Therefore, with the level of information available and through the undertaking of this Case Study, all four Study Areas would be generally considered to be highly vulnerable under these scenarios.

A more detailed application of vulnerability assessment methodology developed specifically for the atoll context would allow a more precise indication of vulnerability. Nonetheless, the Case Study has presented information on the socio-economic and natural system aspects of each Study Area, which allows relative priorities to be set for response action in each Study Area.

○ Study Area 1.

Overall priority for response action - *High*

Rationale:

High population and population density; center of commerce, infrastructure development (sea transport, telecommunications) and government; no special natural system land or marine values; high level of shore alteration and protection.

○ Study Area 2.

Overall priority for response action - *High*

Rationale:

Land available for resettlement due to low population and low population density; critical groundwater resources; low economic land use value; important agricultural land use.

○ Study Area 3.

Overall priority for response action - *High*

Rationale:

Location of essential airport infrastructure; critical rainwater catchment and storage system.

○ Study Area 4.

Overall priority for response action - *Low*

Rationale:

Very low population and low population density; no major economic land use value.

IX Conclusions and Recommendations

Based on the information assembled by this Case Study and the above vulnerability analysis, it is clear that the Marshall Islands are already highly vulnerable to coastal erosion and flooding and that this vulnerability will increase if or when ASLR scenarios become a reality. The risk of potentially serious flooding events exists at the present and will increase under ASLR conditions. More detailed evaluation of vulnerability and planning of appropriate response strategies are required for the present and future situation if lives and property are to be protected.

Detailed vulnerability analysis, using methodology appropriate to the small, low elevation island context, will allow strategic planning for response to ASLR to be developed. The identification of least and most vulnerable areas will provide a critical basis for such planning, as well as an important part of disaster response planning. Erosion of the limited land area of the Marshall Islands will have to be more fully addressed, especially to protect those land areas important to the rapidly growing population. This will require proper planning and major capital investment to stabilise shorelines with shoreline protection structures capable of withstanding extreme event conditions.

As a result of this Case Study, a series of issues, constraints and recommended actions have become apparent. These can be broadly categorised as: 1) Legislative, institutional and organisational, 2) Economical and financial, 3) Technical and 4) Cultural and social considerations. A summary of the constraints, using the format from the Common Methodology (IPCC, 1991), is provided in Table IX-1. The discussion of the issues, constraints and recommendations may provide the Marshall Islands and the international community with an indication of what it will take to deal with ASLR in the Marshall Islands. Overall, the need for Integrated Coastal Zone Management which incorporates response planning for ASLR for the Marshall Islands is clear.

9.1 Legislative, Institutional And Organisational Considerations

9.1.1 Coastal zone management planning

○ Issues and constraints

National legislation (Coast Conservation Act 1988) mandating the development and implementation of a Coastal Zone Management Plan already exists, although a plan and its regulations and procedures has not yet been drafted. The stated purpose of the legislation is to protect and preserve "the coast from sea erosion or encroachment of the sea" and to manage "development activity within the Coastal Zone". Although the RMI EPA is responsible for the Act, it has no technical, financial or human resources dedicated to Plan development or implementation. The baseline information, time series data, long-term studies and data management tools needed for developing an integrated CZM plan which incorporates ASLR are generally not available. There is a particular need to undertake detailed vulnerability analyses of the Marshall Islands, using methods developed for the atoll context.

○ Action recommended

1. Draft a comprehensive Coastal Zone Management Plan that includes addressing ASLR response.
2. Establish, staff and train a CZM Unit within the RMI EPA.
3. Conduct coastal resource inventories and prepare coastal resource atlases, as have been done for Arno and Majuro Atolls.
4. Develop a methodology to determine the vulnerability of low- elevation islands to ASLR.
5. Conduct vulnerability analyses for all of the Marshall Islands as a basis for incorporating ASLR into coastal management planning and developing response options.
6. Assemble the baseline information, commence the time series data collection, start long-term studies and develop data management tools, as detailed in section 9.3.1.
7. Develop and implement a coastal development land use planning, zoning and permit system to regulate shoreline development and ensure that ASLR impacts and mitigation are incorporated into plans, designs and construction.

9.1.2 Environmental planning and management

○ Issues and constraints

Environmental planning and management in the Marshall Islands is relatively advanced for a small developing atoll nation. However, additional efforts will need to be made to incorporate response planning for ASLR. The relevant agencies and mechanisms for environmental planning and management will need to be strengthened to cope with projected effects of climate change.

○ Action recommended

1. Expand and strengthen capabilities of RMI EPA.
2. Strengthen capabilities of Office of Planning and Statistics to better undertake environmental planning.
3. Strengthen capabilities of sectoral resource agencies (marine resources, agriculture, etc.) to incorporate environmental planning and management into resource development.
4. Ensure inter-agency mechanisms for environmental coordination incorporate climate change and ASLR into environmental planning and management considerations.
5. Expand role of National Task Force on Environmental Management and Sustainable Development to include climate change and ASLR in National Environmental Management Strategy development and implementation.
6. Implement the RMI National Environmental Management Strategy Action Plan.

9.1.3 International and regional interaction

○ Issues and constraints

Human and financial resources are limited within low-elevation small island states such as the Marshall Islands. It is very important that regional coordination is fostered to ensure an exchange of information, coordination of studies and assistance and ensure a maximum multiplier effect and a minimum of duplication and overlap. Relevant regional organisations such as SPREP should serve a coordinating and clearinghouse role. International agencies and donors need to coordinate input and assistance on climate change and ASLR activities with each other and regional coordinating units. In-country agencies have a responsibility to assist coordination by keeping regional and international organisations aware of activities which may require coordination to avoid duplication of effort and inefficient use of limited resources.

○ Action recommended

1. Improve in-country coordination capabilities.
2. Strengthen the clearinghouse and coordinating capacity of relevant regional organisations.
3. Ensure coordination of international and donor assistance on climate change and ASLR activities in small island states.

9.2 Economic And Financial Considerations

9.2.1 Development aid and investment

○ Issues and constraints

Much of the economic development activity in the Marshall Islands is driven by assistance from international organisations, multi-lateral development agencies or bilateral aid. Projects funded by these sources do not always incorporate sound environmental planning and management. Climate change and ASLR are generally not taken into consideration at the present. The effects of wave runup, overtopping and flooding and extreme events must be taken into account during project planning, design and implementation. The prospect of serious impacts from ASLR may also deter potential investment in development in the Marshall Islands.

○ Action recommended

1. To the extent possible, require development projects funded by loans or aid from external sources to include consideration of ASLR conditions, including erosion, wave runup, overtopping and flooding, in design and construction parameters. This is particularly important for major infrastructure projects (e.g. roads, airports, ports, public buildings) with a long project life.
2. Encourage or require development funded by external sources to adhere to principles and practices of sound environmental planning and management and sustainable development.
3. Explore the possibility of establishing a scheme to provide insurance against the effects of ASLR to ensure the security of investment and development.

9.2.2 Financial capacity to determine and implement response options

○ Issues and constraints

The Marshall Islands are unable to support the detailed studies, vulnerability analyses and planning required to determine appropriate and feasible options for response to ASLR. The government does not have anywhere near the financial resources to implement large-scale response options, especially major shore protection measures. The shore protection required to withstand design storms and ASLR conditions would consume an inordinate portion of the Marshall Islands budget, which is already heavily dependent on financial assistance from outside the country. Difficult decisions and trade-offs will have to be made, but the Marshall Islands will have to clearly identify that responding to ASLR is a priority by putting whatever local resources possible into addressing the problem. Vulnerability will continue to be high if a commitment is not made, and the assistance found, to identify, specify and implement appropriate response strategies.

○ Action recommended

1. Make efforts to put whatever Marshall Islands resources possible into actions to identify and implement ASLR response options.
2. Seek outside support for the studies, vulnerability analyses and planning required to determine ASLR response options for the Marshall Islands.
3. Obtain the major support required for the implementation of ASLR response options.
4. Evaluate long-term capital expenditure needs of major ASLR responses, especially shoreline structures and other capital intensive options.

9.3 Technical Considerations

9.3.1 Baseline data, time series data and long-term studies

○ Issues and constraints

In order to predict the impacts of ASLR, a baseline understanding of the natural and human systems affected is required, as well information on changes in these systems over time. To understand changes which result from ASLR, it is necessary to separate out other effects, both natural and anthropogenic, on natural and human systems. In addition, tools to effectively handle the data, conduct modeling and make predictions are also required.

The inventories, assessments and estimates called for in the Coast Conservation Act will begin to provide the types of information important for future decision making with regards to coastal management. This Case Study has identified numerous data gaps for which assumptions and generalisations were made. Additional information will greatly improve the ability to develop appropriate response plans.

○ Action recommended

1. Conduct inventories, assessments and estimates required by the Coast Conservation Act and collect baseline information needed for improved and detailed vulnerability analysis, including to:
 - Map nearshore bathymetry at sufficient detail for ASLR modeling and prediction needs;
 - Map topography at sufficient detail for determining ASLR impacts;
 - Map and monitor land use and vegetation for determining relative and absolute value of land areas at risk and trends in land use and vegetation cover;
 - Map and monitor population distribution for determining numbers of people at risk and changes in population distribution;
 - Inventory and monitor coastal resources for determining the status and trends in coastal habitat quantity and quality, especially coral reefs, mangroves and seagrass;
 - Monitor coastal water quality for determining the status and trends in water quality in order to reduce anthropogenic degradation to nearshore habitats and determine trends in water temperature;
 - Monitor beach profiles for determining the status and trends in shoreline deposits;
 - Monitor appropriate oceanographic parameters (e.g. tides, waves, currents, storm waves, etc.) at sufficient detail for modeling and predicting wave action;
 - Conduct sediment budget studies for determining, modeling and predicting sediment production, transport, deposition, erosion and loss within the reef and lagoon system under different oceanographic and ASLR conditions;
 - Monitor appropriate meteorological parameters at sufficient detail for modeling and predicting extreme events and detecting climate trends and participating in regional and global data base, modeling and predicting efforts.
2. An environmental data base and information management system should be established for collecting and collating data for environmental monitoring, planning and management, including addressing ASLR impacts and developing ASLR response plans. Specific actions associated with this are to:
 - Obtain aerial photography and satellite imagery series to assist in baseline mapping and for determining trends, especially for use with GIS;
 - Develop a national Geo Information System (GIS) for conducting rapid, computer-based baseline inventories and monitoring of trends in resource and land use and environmental change.
3. Evaluate the long-term fresh water needs of the growing population and determine the capacity of the fresh water lens', including actions to:
 - Monitor groundwater for determining status and trends in groundwater quantity and quality and modeling groundwater response to different sea level, oceanographic and climatic conditions;
 - Consider how ASLR will reduce fresh water lens in order to begin planning for supplemental fresh water needs.
4. Conduct surveys for determining kinds, amounts and availability of shore protection and landfill materials in Majuro and the Marshall Islands and identify future sources as needed.
5. To the extent possible, obtain, and support efforts to develop, the best possible model predictions for the impacts of regional climate change and ASLR which will improve the predictions available to date.

9.3.2 Planning and response for extreme events

○ Issues and constraints

Extreme events already have a major impact on humans, natural systems and resources and economic development in the Marshall Islands. These include typhoons (tropical cyclones), drought, storm waves and tsunamis. The Marshall Islands National Disaster Committee has been created to plan for and coordinate disaster response, however, there is a need to search for and implement measures to reduce and mitigate the impacts of these events. Although capabilities for extreme event prediction can be improved, there is no need to await further information, modeling or prediction of increased frequency or intensity of these events before taking actions to avoid, reduce or mitigate their impacts. Precautionary planning and effective response is required in the current situation in order to protect property and save lives. This will become even more important under ASLR scenarios.

○ Action recommended

1. Improve tropical cyclone tracking and warning capabilities and tropical cyclone, extreme wind and extreme wave action prediction capabilities.
2. Improve disaster response planning and disaster relief following tropical cyclone, storm wave and tsunami damage.
3. Determine and implement best options for securing a safe, reliable and adequate water supply for Majuro in the face of water shortages and lowered water quality during drought and salinization of groundwater due to wave overwash or reduced rainfall.
4. Develop and implement tropical cyclone preparedness planning, including safe structures, disaster food and water supplies, etc.
5. Develop and apply methodology for determining relative vulnerability for determining areas for retreat.
6. Conduct studies on methods, feasibility and costs of raising structures to accommodate flooding events.

9.3.3 Development planning and projects

○ Issues and constraints

Existing development activities and planned developments are affected by extreme events, especially extreme wind and wave conditions. These effects will likely be worsened due to climate change. Development activities and plans can begin now to take into account ASLR and possible increased extreme event frequency and intensity as a cost-effective, precautionary measure.

○ Action recommended

1. Require shoreline structure design and construction to include parameters for the ASLR projected during the structure life, through EIA and permit procedures.
2. Require all publicly funded development activities and private developments which are insured under public insurance schemes to include ASLR in design and construction parameters.
3. Ensure land use planning which takes into account ASLR, develop required setback limits for different kinds of planned land use and undertake studies to determine how better land use planning can be integrated with the land tenure system of the Marshall Islands.
4. Through EIA and permit procedures, require that the creation of new land by filling in reef flat areas ensures: a) landfill sites are compatible with land use planning which accounts for ASLR and b) landfill design and construction include ASLR.
5. Ensure that EIA and permit procedures require reef flat quarry and lagoon sand dredging site selection and operations (i.e. extraction depth and area) to not exacerbate impacts of ASLR and extreme events.

9.3.4 Natural system adaptation capabilities

○ Issues and constraints

The ability of natural systems to adapt to ASLR is being compromised by human impacts on these systems. This is particularly important for shoreline sediment systems, coral reefs, mangroves and seagrass beds. Precautionary action can be taken now to maintain the capacity of these systems to adapt to ASLR to their best ability. These actions are also necessary in any case as part of more general environmental management required to ensure the sustainability and maximum productivity of these natural systems.

○ Action recommended

1. Maintain coastal water quality for coastal habitats, especially coral reefs.
2. Prohibit destruction of coral reef, seagrass and mangrove communities.
3. Require adequate protection of coral reef communities during development activities (e.g. dredging, coastal construction), especially from effects of turbidity and sedimentation.
4. Regulate beach sand removal, preferably with complete prohibition, and strictly enforce regulations.

9.4 Cultural And Social Considerations

9.4.1 Geopolitical issues

○ Issues and constraints

The partial loss of land in the RMI may lead to loss of base points for EEZ boundaries, which could considerably reduce Marshall Islands territory with its important pelagic and sea bottom resources. Severe inundation or the total loss of land could result in the Marshall Islands ceasing to be physically habitable, which raises problems of migration, resettlement, cultural survival and sovereignty. These important issues have not been resolved in the international discussions on climate change.

○ Action required

1. Achieve international agreement on land loss due to ASLR and possible EEZ change through the framework of the Law of the Sea.
2. Commence international discussions on considerations for nations potentially rendered uninhabitable by ASLR and climate change.

9.4.2 Land and population pressures

○ Issues and constraints

Only some parts of the Marshall Islands may be able to be protected from the impacts of ASLR. Other islets or whole atolls may become unsafe or unsuitable for permanent habitation. In such a case, those areas which are protected or saved for habitation will have to accommodate more people through the creation of more land and/or the construction of high rise dwellings. This will exacerbate the rapid rate of urbanisation which is already resulting from the rapid rate of population growth, both of which have led to serious environmental and social problems for Majuro Atoll and the Marshall Islands. The loss of land and creation of new land will complicate the important land tenure situation in the Marshall Islands.

○ Action recommended

1. Undertake studies to determine potential landfill areas and landfill material sources to create new land for immigrants into areas which vulnerability analyses have indicated are relatively safe from ASLR effects.
2. Undertake studies to determine suitable areas and kinds of high rise, multi-unit accommodation appropriate for Majuro, including full environmental analysis of the impacts.
3. Develop policy and plans to address and resolve land tenure implications of land loss and land creation and major population movement between islands.

Table IX-1: Constraints related to implementation feasibility

Implementation Aspects	Problem	Partial Problem	No Problem
<i>Legislative, Institutional and Organisational</i>			
Level A: - existing CZMP legislation			X
- existing inst./orgs. in CZMP		X	
- executive powers for CZMP			X
Level B: - spec. of tasks/responsibilities		X	
- communication structure		X	
- staffing/facilities	X		
- existing CZMP plan, etc.	X		
Level C: - staff education level	X		
- knowledge/managment capabilities	X		
- staff motivation/work conditions	X		
<i>Economic and Financial</i>			
Level A: - national economic capacity	X		
Level B: - national funding potential	X		
- regional funding potential		X	
- international funding potential		X	
Level C: - financial management capability		X	
<i>Technical</i>			
Level A: - technical knowledge/experience	X		
- technical institutions	X		
Level B: - operational structures	X		
- staffing and facilities	X		
Level C: - staff education level	X		
- tech. qualification/capability	X		
- staff motivation	X		
- data availability	X		
<i>Cultural and Social</i>			
Level A: - cultural constraints	X		
- socio-economic constraints	X		
Level B: - cultural programmes	X		
- socio-economic programmes		X	
Level C: - recent cultural achievements			X
- recent socio-economic achievements			X

Note: Level A: Institutional constraints
 Level B: Operational constraints
 Level C: Quality constraints (effectiveness)

References

- Asian Development Bank (ADB). 1991. *Economic report on the Republic of the Marshall Islands*. ADB, Manila.
- Bruun, P. 1962. *Sea-Level Rise as a Cause of Shore Erosion*. ASCE J. of Waterways and Harbors Div., Vol. 88, ww1.
- Callies, D.L. and C.J. Johnson. 1989. *Legal, Business, and Economic Aspects of Cobalt-rich Manganese Crust Mining and Processing in Republic of the Marshall Islands*. University of Hawaii, Sea Grant.
- Dames and Moore. 1979. *Coastal and Geotechnical Investigation: Marshall Island Docks Project: TTPI Capital Improvement Program: Marshall Islands*, Prepared for the US Army Corps of Engineers, Pacific Division, Contract no. DACA (TTPI) 84-78-C-0056.
- Defense Mapping Agency. 1976. *Sailing Directions for the Pacific Islands*. Vol. I.
- Hamilin, S.N. and S.S. Anthony. 1987. *Ground-Water Resources of the Laura Area, Majuro Atoll, Marshall Islands*. US Geological Survey, Water-Resources Investigations Report 87-4047.
- Intergovernmental Panel on Climate Change (IPCC). 1991. *The Seven Steps to the Vulnerability of Coastal Areas to Sea Level Rise: A Common Methodology*. Response Strategies Working Group (Revision 1).
- Joint Typhoon Warning Center, Guam. *Annual Typhoon Report*.
- Manoa Mapworks. 1989. *Majuro Atoll Coastal Resource Atlas*. United States Army Corps of Engineers, Pacific Ocean Division, Honolulu, HI.
- Maragos, J.E., Des Rochers, K. and P. Rappa (eds.). 1990 (DRAFT). *Coastal Resource Inventory of Majuro Atoll, Republic of the Marshall Islands*. [Draft only - available from Sea Grant Extension Service, University of Hawaii].
- Miller, P.L. and F.T. MacKenzie. 1988. *Implications of Climate Change and Associated Sea-Level Rise for Atolls*. In: Proceedings of the 6th International Coral Reef Symposium, Australia, 1988. vol 3.
- Mase, H. 1989. *Random Wave Runup Height on Gentle Slopes*, *Journal of Waterway, Port, Coastal and Ocean Engineering*. ASCE, Vol. 115, No.5.
- Nakazaki, E. 1985. *Bottom Shear Stress, Wave Height and Wave Set-up Under Wave Transformation*. PhD dissertation, University of Hawaii, Department of Ocean Engineering, Honolulu, Hawaii.
- National Oceanic and Atmospheric Administration (NOAA), Local Climatological Data, Majuro, Marshall Islands, Pacific.
- National Oceanic and Atmospheric Administration (NOAA). 1989a. *Climatological Data Annual Summary: Hawaii and Pacific*. 1989. Vol 85, No 13.

- National Oceanic and Atmospheric Administration (NOAA). 1989b. *Local Climatological Data; Annual Summary with Comparative Data, Majuro, Marshall Islands.*
- Office of Planning and Statistics (OPS). 1986. *First Five Year Development Plan, 1986-91.*
- Office of Planning and Statistics (OPS). 1989a. *Statistical Abstract, 1988/89.*
- Office of Planning and Statistics (OPS). 1989b. *Census of Population and Housing, 1988.*
- Office of Planning and Statistics (OPS). 1991a. *Statistical Abstract 1989/90.*
- Office of Planning and Statistics (OPS). 1991b. *National Population Policy.*
- Office of Planning and Statistics. 1991c (OPS). *Second Five Year Development Plan, 1992-96.*
- Pilkey, O. 1990. *Assessment of Coastal Erosion on Majuro Atoll*, submitted to RMIEPA, December, 1990.
- Republic of the Marshall Islands (RMI). 1992. *National Environmental Strategy. Part A: State of the Environment report.*
- Rocheleau. 1977. *Evaluation of Extreme Wind and Wave Climate in Hawaii*, J.K.K. Look Lab. of Oceanographic Engineering, Dept. of Ocean Engineering, Univ. of Hawaii, Tech. Rep. No. 41.
- Rosti, P. 1989. *Circulation and Shoreline Survey of Majuro Atoll, Republic of the Marshall Islands.* Prepared for Sea Grant Extension Service, Univ. Of Hawaii, and the Environmental Resources Branch, US Army Corps of Engineers, Pacific Ocean Div., Honolulu, Hawaii.
- Sea Engineering, Inc. 1983. *Bathymetric survey and route reconnaissance to support planning and design of the proposed ocean outfall for Majuro Atoll, Marshall Islands.* Prepared for Barret, Harris and Associates, Inc. Honolulu, Hawaii.
- Sea Engineering, Inc. and R.M. Towhill Corp. 1988. *Shoreline inventory and protection study: US Army Kwajalein.* Prepared for US Army Corps of Engineers, Pacific Ocean Div.
- Spennemann, D. H.R. and N.I. Lajuan. 1990. *Investigations of a Mangrove Area on Delap, Majuro Atoll, Republic of the Marshall Islands.*
- Tobin, J.A. 1958. Land tenure in the Marshall Islands. In: De Young, J.E. (ed.), *Land Tenure Patterns in the Trust Territory of the Pacific Islands.* Trust Territory Government, Saipan.
- U.S. Army Corps of Engineers. 1984. *Shore protection manual.* Coastal Engineering Research Center.
- U.S. Army Corps of Engineers. 1985. *Design of coastal revetments, seawalls and bulkheads.* Coastal Engineering Research Center.

Annexes

Annex 1: Calculating Design Waves

1. Two-Year And 50-Year Waves

The results of statistical analysis of the SSMO wave data are applied to the ocean side shorelines. Wave heights of 13 feet and 19 feet are estimated for the 2-year and 50-year waves, and are shown on Table II-6. The wave period for these waves are estimated to be 13 seconds based on the wave data in Table II-5.

Waves in the lagoon are generated by local winds. The 2-year and 50-year fastest mile wind speeds are used to estimate the corresponding wave heights and wave periods. The wind speeds are 34 mph for the 2-year wind speed and 47 mph for the 50-year wind, as shown in Table II-3. These wind speeds are converted to 10-minute averaged wind speeds, and then are further converted to wind stress factors, which are used in the wave calculations. The 2-year and 50-year wind stress factors are 39 mph and 56 mph. These conversions were made using methodology described in the Shore Protection Manual (US Army Corps of Engineers, 1984).

Wave generation for a given wind speed is dependent on the water depth and the fetch length. An average water depth of 140 feet was used for a calculation of wind waves in the lagoon. The fetch length is the longest straight line across the lagoon for which the respective Study Area is exposed. The fetch length for Study Areas 1 and 2 is 21 n.m. and for Study Areas 3 and 4 is 6 n.m. The wave height and period in the lagoon are calculated using the following equations:

$$\frac{gH_s}{U_A^2} = 0.283 \tanh \left[0.530 \left(\frac{gd}{U_A^2} \right)^{3/4} \right] \tanh \left[\frac{0.00565 \left(\frac{gF}{U_A^2} \right)^{1/2}}{\tanh \left[0.530 \left(\frac{gd}{U_A^2} \right)^{3/4} \right]} \right]$$

$$\frac{gT}{U_A} = 7.54 \tanh \left[0.833 \left(\frac{gd}{U_A^2} \right)^{3/8} \right] \tanh \left[\frac{0.0379 \left(\frac{gF}{U_A^2} \right)^{1/3}}{\tanh \left[0.833 \left(\frac{gd}{U_A^2} \right)^{3/8} \right]} \right]$$

where, H_s = significant wave height (feet)
 T = wave period (sec.)
 U_A = wind stress factor (ft/sec)
 d = water depth (feet)
 g = acceleration of gravity (ft/sec²)

The wave conditions for the 2-year and 50-year events are presented in Table II-10.

2. Typhoon Waves

The worst case storm waves are calculated by using the scenario typhoon parameters defined previously. The deepwater typhoon wave conditions on the ocean side of the atoll are calculated from the following equations:

$$H_s = 16.5 e^{\frac{R \Delta P}{100}} \left(1 + \frac{0.208 a V_F}{\sqrt{U_R}} \right)$$

$$T = 8.6 e^{\frac{R \Delta P}{200}} \left(1 + \frac{0.104 a V_F}{\sqrt{U_R}} \right)$$

- where, H_s = deep water significant wave height (feet)
 T = significant wave period (sec)
 R = radius of maximum wind (n.m.)
 P = pressure reduction (inches of mercury)
 V_F = forward speed of the typhoon (knots)
 U_R = maximum sustained wind speed at R (knots)
 a = a coefficient = 1.0

Typhoon wave heights on the lagoon side of the atoll are calculated using the same methodology used for the 2-year and 50-year events. A maximum sustained wind speed of 75 knots is converted to a wind stress factor of 122 knots. The calculated ocean side and lagoon side typhoon wave conditions are shown in Table II-10. The wave heights shown are significant wave height, or average of the highest one-third of all waves. This is the statistical wave height generally used for design of rubblemound shore protection structures. Storm waves are irregular, and often higher, less frequent wave heights are used when a more conservative design wave is required. The highest 10 percent wave heights and highest one percent heights are approximately 1.3 and 1.7 times the significant wave heights, respectively.

Annex 2: Calculating Still Water Level Rise.

1. *Astronomical Tide*

To take account of astronomical tides, a tide level of +2.6 feet above MSL, equal to mean high water is considered appropriate for shore protection design due to its frequency of occurrence.

2. *Storm Surge*

The storm surge is a combination of the pressure setup and the wind setup. The water level rise due to reduction of atmospheric pressure associated with a storm is determined by:

$$S_p = 1.14 \Delta P$$

where S_p is pressure setup, and P is pressure reduction from the normal atmospheric pressure in inches of mercury. Based on predicted atmospheric pressures in Table II-8, the 2-year pressure setup is 0.3 feet, and 50-year pressure setup is 0.4 feet. For the scenario typhoon P is 1.5 and the calculated rise is 1.7 feet. It is assumed that these pressure reductions occur together with the associated wave and wind events.

The rise in water level along a shoreline due to wind blowing over the water surface can be estimated by:

$$S_u = 540 KU^2 \Delta x/d$$

where, S_u = wind setup increments in feet
 $K = 3.0 \times 10^{-6}$
 U = wind speed in knots
 Δx = increment of horizontal distance in n.m.
 d = average water depth in feet over Δx .

Wind setup on lagoon side shores are calculated over the fetch distance used to calculate lagoon design wave heights. Wind setup on the ocean side is considered negligible because deep water extends right up to the shoreline. The storm surge is a combination of the pressure setup and the wind setup.

3. *Wave Setup*

Wave setup is the change in the mean water level caused by momentum flux changes in a train of waves of changing amplitude. The excess momentum flux due to waves is termed "radiation stress." Wave setup was calculated by numerically solving the following horizontal momentum equation:

$$\frac{dS_x}{dx} + \rho g (h+\eta) \frac{d\eta}{dx} = 0$$

where, η = wave setup
 x = horizontal distance perpendicular to shore
 h = water depth excluding wave setup
 ρ = density of sea water
 g = acceleration of gravity
 S_x = the radiation stress component along the x-axis.

The radiation stress component, S_x , is determined using the following equation:

$$S_x = E (2n - 0.5)$$

where, n = the ratio of the wave group velocity to the phase velocity = $[1 + 2kh/\sinh(2kh)]/2$
 E = the mean wave energy per unit area = $\rho g \sigma^2$
 σ = the standard deviation of sea surface elevations

An empirical relationship between wave height and the standard deviation of sea-surface elevations (Nakazaki, 1985) is used to decide changes in wave energy according to nearshore wave nonlinearity. The relationship agrees well with a family of curves presented in the Shore Protection Manual (US Army Corps of Engineers, 1984) that are based on stream-function theory. Wave setups are calculated for selected bottom profiles at each Study Area for the 2-year, 50-year and typhoon wave conditions, using three ASLR values of 0, 1 and 3.3 feet. For simplicity the wave refraction coefficient is assumed to be unity.

4. Total Still Water Level Rise

The total water levels rise along Study Area shorelines are summarized for each ASLR value in Tables II-11 to II-16. Study Area 4 is not a continuous coastline, but rather a group of islets. Water pushed up into this area can flow between the islets, thereby reducing setup. The water level rises for Study Area 4 therefore include wave setup reductions to account for this effect. A linear water level reduction is applied over a horizontal distance from the initial wave breaking point to the lagoon side shoreline. The initial wave breaking point is the point of maximum setup, while the lagoon side shoreline has 0 setup.

Annex 3: Study Area Shoreline Inventory

1. Study Area 1

Shoreline Conditions and Characteristics

Photo no.	Profile no.	Description	Evidence of Shoreline Damage
1	-	A jetty at boat channel.	In good condition.
2	-	20-30 foot wide beach with gravel and cobble. Beach slope of 30%. Riprap revetment along 3300- foot road section seems to exist under gravel.	Tree root exposure and wave overtopping.
3 & 4	-	1-5 ton quarystone revetment without crest. Top of the revetment is 9 feet MSL.	Significantly moved armor stones, damaged filter cloth exposure and loss of earth behind the revetment.
5	-	A pile of old cars and heavy metal equipment.	None
6	-	A 6-foot high, 150- foot long vertical wall, toppled.	Overturned vertical wall and eroded fill material along the wall.
7	-	Randomly placed stones over beach slope, with stones 1- 4 feet in diameter.	Scattered stones and erosion scarp 1-2 feet high at top of beach.
8	-	Flat narrow beach of coarse sand, gravel and cobbles.	Exposed tree roots and toppled trees.
9	-	Shore of reef rock and short seawalls.	Erosion at toe of seawalls.
10	-	Shore of reef rock, gravel and cobble with a few shore seawalls.	Damaged seawalls.
11	-	150-foot long, 6-foot high gabion wall with a filter cloth at land filled section.	Earth erosion behind the wall caused by waves overtopping.
12	-	Storm tossed berm of sand, gravel and cobbles.	Tree root exposure.
13	-	About 300-foot long, 6-foot high curved face concrete wall, and casually placed 2-5 ton boulders.	Sign of rebar corrosion and unstable boulders.
14	-	Sand beach piled by storm waves against building walls.	Narrow, steep beach with sand piled against building walls.
15	-	Beach of reef rock, gravel, cobbles with scattered sand.	Tree root exposure.
16	-	80-foot damaged concrete rubble wall.	Tomb stones fallen on beach slope and exposed tree roots.
17	-	8-foot high, 200-foot long concrete vertical wall.	In good condition.
18	-	Vertical seawall 4-8 feet high and 700-foot long.	In good condition.
19	-	A berm with gravel and cobbles.	Tree root exposure.
20	-	Seawalls and narrow beach.	Destroyed seawalls.
21	-	6-foot high, 200 foot long gabion wall, and stones randomly piles on beach slope.	Stones moved and scattered on the reef.
22	-	Reef rock, cobble beach.	Tree root exposure.
23	-	Reef rock, cobble beach with thinly scattered sand.	No evidence of damage.
24	-	Low and flat sandy beach.	Tree root exposure.
25	-	Reef flat rock with thin coarse sand layer, and seawalls protecting individual properties.	Tree root exposure.

Photo no.	Profile no.	Description	Evidence of Shoreline Damage
28 & 29	-	Very narrow coarse sand beach, and seawalls protecting individual properties.	Tree root exposure.
30 & 31	-	Very narrow gravel beach and about 60 feet long quarystone revetment.	Tree root exposure.
32 & 33	-	Gravel and cobble beach.	Shoreline retreat from old shoreline position, which is indicated by concrete armor units. Erosion scarp 1-2 feet high.
34	-	Individual property seawalls.	Shoreline retreat at unprotected sections between seawalls.
35 & 36	-	6-foot high, 200-foot wall of sandbags and gabions at a new landfill area.	Concrete floor undermined and damaged.
37 & 38	-	Low 2-4 ton coral stone revetment.	Missing armor stones and loss of fill material.
39 & 40	-	Seawalls and very narrow coarse sand and gravel beach.	Unprotected shoreline retreat between seawalls.
41 & 42	-	150-foot long sandy beach.	3-5 inch high erosion scarp.
43 & 44	-	Seawall and segmental sandy beaches.	Tree root exposure.
45 & 46	-	30-foot wide, 400-foot long fine sand beach with scattered gravel.	Erosion scarp up to 1 foot high.
47 & 48	-	Both ends of a 500-foot long seawall.	Toppled trees, erosion at ends and behind the wall. Leaning wall and crack lines on the wall.
49	-	2,000-foot gravel and coarse sand shoreline along the park.	2-3 foot high erosion scarp and tree root along exposure.
50	-	200-foot long riprap.	1-foot erosion scarp behind the riprap. Heavily moved stones.
51 & 52	-	Old cars dumped for shore protection.	Loss of earth fill.
53	-	250-foot long dock with deck elevation of about 6 feet (msl).	Broken fenders.
54 & 55	-	1,000-foot long dock with deck elevation of 9-foot high (msl) dock.	Broken fenders and heavily damaged curbs.
56	-	Narrow gravel beach.	Tree root exposure.
57	-	Narrow beach with gravel and cobbles.	Toppled trees.
58	-	100-foot long, 4-5 feet wide jetty with 1-4 ton quarystone next to boat ramp.	Broken jetty.
59 & 60	-	Stones and trees dumped for shore protection at a land fill area.	Loss of earth.
61 & 62	-	1-3 ton stone revetment without crest at boat channel.	Some missing stones and earth loss.

2. Study Area 2

1	-	50-foot wide beach with fine to medium grain sand. Beach slope 1/10.	Tree root exposure.
2	1	50-foot wide beach with fine to medium grain sand. Beach slope of 1/10.	Tree root exposure.
3	-	30-foot wide beach with gravel and cobbles. Beach slope of 1/5.	Tree root exposure.

Photo no.	Profile no.	Description	Evidence of Shoreline Damage
5 & 6	3	Over 100-foot wide beach with fine to medium sand. Beach slope of 1/10.	Erosion scarp 2 feet high. Tree root exposure.
7	4	50-foot wide beach with fine to medium sand. Beach slope of 1/10.	Tree root exposure.
8	5	50-foot wide beach with fine to medium sand. Beach slope of 1/10.	Tree root exposure.

3. Study Area 3

1	6	0.5 ton rock revetment with crest on lagoon side of airport shoreline.	Revetment in good condition.
2, 3 & 4	-	On ocean side runway, 1-4 ton rock revetment with 8-foot high crest and 1 on 2 slope.	Armor stones moved from original position and earth behind the revetment eroded by waves overtopped.
5	-	West end of runway ocean side. 1-4 ton rock revetment with crest.	Revetment in good condition.
6	-	Riprap on lagoon side along causeway with 1 on 2 slope and 7-foot crest elevation (msl).	Riprap settled in a stable slope. No shoreline erosion.
7	-	Riprap revetment on ocean side along causeway with 1 on 2 slope and 7.5-foot crest elevation (msl).	Riprap revetment settled in a stable slope. No shoreline erosion.
8	7	30-40 foot wide sandy beach on lagoon side of island, with fine to medium grain sand and beach slope of 1 on 5.	Erosion scarp 1-2 feet high with tree root exposure.
9	-	Thin layer of gravel over flat reef rock on ocean side of island.	Tree root exposure.
10	8	50-70 foot wide sandy beach on lagoon side of island, with fine to medium sand and beach slope of 1 on 10.	Beach scarp of 2-3 feet high and toppled trees.
11	-	20-30 foot wide beach on ocean side of island, with gravel and cobbles.	Toppled trees and tree root exposure.

4. *Shoreline Profile data*

Profile 1		Profile 2		Profile 3		Profile 4	
Dist. (feet)	Elev. (feet)	Dist. (feet)	Elev. (feet)	Dist. (feet)	Elev. (feet)	Dist. (feet)	Elev. (feet)
0	0	0	0	0	0	0	0
35	3.1	25	2.4	25	2.1	40	4.1
60	5.9	45	7.3	50	5.1	50	5.1
70	7.3	60	10.5	70	5.0	65	5.5
105	9.6	70	11.3	85	5.3	90	5.5
145	9.6	85	10.9	95	7.3		
160	10.2			175	8.3		
205	10.1						
235	10.8						

Profile 5		Profile 6		Profile 7		Profile 8	
Dist. (feet)	Elev. (feet)	Dist. (feet)	Elev. (feet)	Dist. (feet)	Elev. (feet)	Dist. (feet)	Elev. (feet)
0	0	0	0	0	0	0	0
50	3.8	15	1.4	35	1.5	50	6.2
60	4.8	30	1.0	60	5.5	60	8.4
70	5.1	40	7.9	65	7.0	75	9.0
200	8.9	45	5.2	120	5.0	100	9.9
		50	4.6				

Note: Elevations are above mean sea level.

Annex 4: Land Area and Population Density by Island (1988)

Atoll/Island	Land Area (sq mi)	Population Density (people/sq mi)		
		1973	1980	1988
Ailinglaplap	5.67	194.0	244.3	302.0
Ailuk	2.07	164.2	199.2	236.0
Arno	5.00	224.0	297.4	332.0
Aur	2.17	138.2	204.6	202.0
Bikini	2.32	32.3	0.0	4.0
Ebon	2.22	333.3	349.5	334.0
Enewetak	2.26	0.0	239.8	316.0
Jabat	0.22	318.2	327.3	509.0
Jaluit	4.38	211.2	331.1	390.0
Kili	0.36	1,000.0	1,358.3	1,672.0
Kwajalein	6.33	864.0	1,046.4	2,357.0
Lae	0.56	275.0	423.2	570.0
Lib	0.36	272.2	272.2	319.0
Likiep	3.96	102.5	121.5	122.0
Majuro	3.75	2,744.0	3,144.3	5,244.0
Maleolap	3.75	114.0	162.0	210.0
Mejit	3.79	376.0	451.4	618.0
Mili	6.15	87.5	124.1	139.0
Nomorik	1.07	402.8	576.6	761.0
Namu	2.42	203.7	270.2	331.0
Rongelap	3.07	53.7	76.5	--
Ujae	0.72	290.3	429.2	622.0
Ujelang	0.67	510.4	0.0	--
Utirik	0.94	230.9	357.4	435.0
Wotho	1.67	36.5	50.4	54.0
Wotje	3.16	134.5	169.3	204.0

Annex 5: Calculating Erosion

Bruun (1962) devised a rule governing shoreline erosion. The rule states that a beach that has attained equilibrium with coastal processes will respond to a rise in sea level by losing sand from the upper part of the beach profile and gaining it in the nearshore area until a new equilibrium is established. Thus, the coastline will retreat (1) as the direct result of the sea level rise, and (2) as a result of the beach erosion.

The Bruun rule of erosion concerns a long-term budget of onshore/offshore movement of sandy material. The rule is based on the assumption of a closed sand balance system between the beach and nearshore area and the offshore bottom profile. The difficulty lies in clear definitions of boundaries in relation to the composition of the materials of which the shores are built. Depending on the sand grain size, the boundary depth may extend to shallower or deeper water. The ultimate limit for movement characterized by threshold water motion velocities is in the order of 3.5 times the design wave height (Bruun, 1986).

The balance between eroded and deposited sediment is given by a following relationship:

$$X(e + d) = ab$$

- where,
- a = sea level rise
 - b = sediment deposit width (horizontal distance between the shoreline and a point where the water depth is d)
 - d = water depth = 3.5 H (H = design wave height)
 - e = shore elevation above MSL.
 - X = shoreline erosion

On the ocean side, we assume that the eroded sediment deposits only over the reef without losing it offshore and thus b is equal to the reef width. This is likely conservative, and underestimates sand loss. The reef elevation is equal to mean low water level, a water depth of 1.8 feet. On the lagoon side, b is determined according to the 50-year design wave height, from Section II.

Annex 6: Calculating Wave Runup and Innundation

Wave runup is computed by adding wave runup elevation to total stillwater rise (see Figure). An experimental wave runup relationship (Mase, 1989) is used to estimate wave runup on the shoreline in the Study Area. The relationship is the following:

$$\frac{R_s}{H_o} = a \left(\frac{\tan\theta}{\sqrt{H_o/L_o}} \right)^b$$

for $\frac{1}{30} \leq \tan\theta \leq \frac{1}{5}$ and $0.007 \leq \frac{H_o}{L_o}$

and where,

- R_s = significant wave runup
- H_o = equivalent deepwater significant wave height
- L_o = deepwater wave length
- $\tan\theta$ = shoreline slope
- a = coefficient = 1.38
- b = coefficient = 0.70

The formula determines significant wave runup heights of random waves on gentle, smooth and impermeable slopes. The significant wave runup is the average of the highest one-third of all runup, and to represents the inundation that could be expected to occur. However, some wave runup will exceed the significant wave runup, R_s ; the excess runups over R_s are in order of 70, 35, and 23 % for the maximum runup, the top 2-percent average runup, and the top 10-percent average runup, respectively. This occasional greater runup may be a threat to populated areas.

The relationship expressed above is based on experiments using simple plane slopes. Saville's method of composite slopes as presented in the Shore Protection Manual is used to approximate the single runup slope needed for computations involving irregular shoreline profiles, which invariably exists. The wave runup model used in this study is a combination of the runup equation proposed by Mase and Saville's method of composite slopes.

Runup is decreased by roughness on the slope and by slope permeability. The choice of roughness factors to be applied to wave runup on natural and man-made shorelines is difficult because of their complex and variable nature. For this study a roughness factor of 0.85 is used.

Annex 7: Shore and Flooding Protection:

Structure and Design Considerations

1. General Design Considerations

- Selection of structure

Revetments:

A revetment is a facing of erosion-resistant material whose primary purpose is to protect a shoreline from direct erosion by waves. It is one of the surest time-proven shore protection measures. The most common method of revetment construction is to place an armor layer of stone or concrete units over an underlayer and bedding layer. The armor stones are sized according to the design breaking wave height. The underlayer and bedding layer are designed to distribute the weight of the armor layer and to prevent loss of shoreline material through voids in the revetment. Simpler, less costly revetment designs using riprap, concrete blocks or concrete rubble can be used in low wave height environments.

Generally, the slope of the revetment should not be steeper than 1 vertical to 1.5 horizontal. Toe protection can be provided by placing the toe on solid substrate where possible (e.g., reef rock that extends along the shoreline), by constructing the foundation as much as practicable below the maximum depth of anticipated scour, or by extending the toe seaward to provide excess stone to fill the possible scour trough. Properly designed rock revetments are durable, flexible, and highly resistant to wave damage. If toe scour should occur, the structure can settle and readjust without major failure. The revetment can still function effectively even if damaged. The rough and porous surface and flatter slope absorb more wave energy than smooth vertical walls, thus reducing wave reflection, runup and overtopping.

Seawalls:

A seawall is a vertical or sloping reinforced concrete or grouted masonry wall used to protect the land from wave damage, with use as a retaining wall a secondary consideration. A seawall may be either a gravity or pile-supported structure, with stepped, vertical or recurved seaward face. A seawall, if properly designed and constructed, is a proven, long lasting, low maintenance shore protection method requiring limited horizontal space along the shoreline.

The near vertical seaward face of seawalls cause problems. Wave energy is deflected both upward and downward. The down ward component can cause severe scour at the base of the wall, particularly in shallow waters, and adequate toe protection is necessary. Ideally the wall should be constructed on solid, non-erodible substrata. Undermining of the toe is one most common causes of seawall failure. Seawalls are inflexible structures and failure of one section can often initiate failure of the entire wall. Because they dissipate little wave energy, smooth, vertical seawalls are also more easily overtopped by waves than sloping irregular walls. In addition, the near-perfectly reflected waves from the vertical wall carry sand seaward, causing beach erosion in front of the structure.

Bulkhead:

A bulkhead is a vertical wall constructed of steel or concrete sheet piles driven into the ground and stabilized by tie backs. The primary purpose of a bulkhead is to retain landfill, with the secondary purpose of protection against wave damage. Bulkheads are often used in sheltered waters or in harbors. The smooth vertical face of a bulkhead does not absorb wave energy and is easily overtopped by waves and spray. They are also subject to toe scour. Steel sheetpiles are generally used for wharves and docks because of their ability to absorb vessel docking forces without cracking. Steel sheetpiles, however, rapidly deteriorate due to corrosion in the saltwater environment. The estimated steel sheetpile life is 15 to 20 years, even when initially covered with a bitumastic coating.

The steel sheetpile has the advantage of being able to be driven into hard substrate, and their joints are tight that prevents the loss of fine material from behind the bulkhead. Prestressed concrete sheetpile provides durable, long lasting protection, but they cannot be driven into a hard bottom area with buried rubble. Even when driven into soft substrate, a gap between the joints often occurs, permitting the erosion of fines from the fill material behind them. Bulkheads are not appropriate for shore protection, and their use should be limited to retaining structures in the port docking areas.

○ Structure height

Revetment and seawall crest elevations are designed to be high enough to prevent significant wave overtopping, which causes scour to the landward side of the structure and to reduce inland flooding. Ideally revetments and seawalls can be built high enough so that no water can overtop the crest of the structure, despite the water level rise and severity of wave attack. In some cases, however, it is not feasible and economically justifiable to construct a non-overtopping structure.

A vertical height to which an incident wave runs up over the structure slope determines the required structure height. Runup depends on the structure shape and roughness, the water depth at the structure toe, the bottom slope seaward of the structure, and the incident wave characteristics. Methodology used in runup calculations is described in the Shore Protection Manual (U.S. Army Corps of Engineers, 1984). The method is based primarily on laboratory model tests for runup on smooth impermeable slopes. Rough and porous slopes reduce the runup, as shown by the following ratio (r) between runup on a rough permeable slope and a smooth impermeable slope:

	r
Smooth, impermeable slope	1.0
Grass	0.9
Fitted Blocks	0.85 - 0.9
Riprap	0.65 - 0.8
Rock or Concrete Armor Units	0.5

○ Toe and flank protection

It is important to ensure that the foundation of any structure placed on the shoreline is adequate to protect against failure due to scour and undermining of the toe by wave action. This is particularly significant for seawalls, where the downward component of reflected wave energy can cause severe scour at the base of the wall. Ideally the shore protection should be constructed on solid, non-erodible substrata. When shore protection is constructed on erodible material, scour at the toe of the structure may form a trough. The dimensions of the trough are governed by the type of structure face, the nature of wave attack, and the erosion resistance of the foundation material. Seaward of a rubble mound revetment scour may undermine the toe stone, causing stones to sink to a lower, more stable position. The resultant settlement of stone on the seaward face may be dealt with by overbuilding the cross section to allow for settlement. Another method is to provide excess stone at the toe to fill the anticipated scour trough.

The toe of a vertical structure may be protected similarly against scour by using stone. An impermeable cutoff wall at the base also may be used to protect a seawall from undermining by scour. "As a general guide, the maximum depth of a scour trough below the natural bed is about equal to the height of the maximum unbroken wave that can be supported by the original depth of water at the toe of the structure (SPM, 1984)."

A revetment or seawall protects only the land and improvements immediately behind it. Where erosion is expected to continue at ends of the structure, wing (return) walls or tie-ins to adjacent land features must be provided to prevent flanking.

- Availability of construction materials

The cost and choice of alternative shore protection designs for Majuro Atoll is dependent on the availability of construction material. The first choice for revetment material is limestone, quarried directly out of the surrounding reef flat. Revetments can also be constructed with cast concrete armor units. Coral aggregate and sand for use in the concrete mix is more readily available and can be obtained directly from the lagoon or old quarry sites.

- Design wave height at shore

When deepwater waves travel into increasingly shallower water, wave shoaling occurs, with the wave height increasing as the wave speed decreases. The waves travel toward shore until the water depth becomes shallow enough to initiate wave breaking. The large deepwater waves initially break some distance offshore, at the edge of the reef flat, and then reform and continue shoreward as smaller waves. The waves may break and reform several times before finally reaching shore.

A computer model has been used to calculate the design wave heights at shore based on the deepwater design waves, which are defined in Section II. The model includes wave shoaling, wave setup, and wave energy dissipation effects due to bottom friction and wave breaking. The design wave heights calculated for the Study Area are shown in Table IV-1. Shore protection structures are designed based on the design waves at shore.

2. *Revetment Design*

- General

A rubble mound revetment is generally composed of a bedding/filter layer of gravel, spalls and graded quarry-run stone covered by one or more under layers of larger stone and an armor layer of large quarystone or concrete armor units. The armor layer maintains its position under wave action through its weight and interlocking of the individual units. The units are sized according to the design wave height and the stability characteristics of the armor units being used. Quarystone or concrete armor revetments are generally used when the design wave height exceeds about five feet, and can be designed for virtually any extreme wave attack.

For design wave heights less than five feet, less costly revetment designs can be used. Riprap revetments are constructed of a gradation of sizes between upper and lower limits instead of the underlayer and armor layers. Other low wave height revetment designs include flexible or rigid concrete blocks, and the use of concrete rubble from the demolition of pavement and buildings. A detailed summary of revetment types is contained in U.S. Army Corps of Engineers (1985).

The following alternative revetment designs are considered reasonable for the Study Area, considering the design wave conditions, the nature of the existing shorelines, and the availability of construction materials. The design of typical sections for each alternative follows the methodology in the Shore Protection Manual (U.S. Army Corps of Engineers, 1984) and Design of Coastal Revetments, Seawalls and Bulkheads (U.S. Army Corps of Engineers, 1985).

○ Quarystone or concrete armor revetment

A properly designed and constructed rubble mound revetment provides good protection under severe wave attack, and is generally requires little or no maintenance. Because of the limited quantities of available quarried reef rock armor stone, concrete armor units may have to be used in the future. The typical revetment designs discussed in this report include quarystone, concrete cubes and a single layer of concrete tribars as the armor layer.

Armor Unit Weight:

The required armor unit weight is given by:

$$W = \frac{W_r H^3}{K_D (S_r - 1)^3 \cot \theta}$$

where, W = weight in pounds of an individual armor unit

W_r = unit weight of armor unit (use 140 lbs/ft³)

H = design wave height

S_r = specific gravity of armor unit (use 2.2)

θ = structure slope

K_D = armor unit stability coefficient:

quarry stone, two layers random placed = 2

concrete cubes, two layers randomly placed = 2

tribar, one layer uniform placed = 12

A range of ± 25 percent of the calculated required weight is acceptable for quarystone revetment armor.

Underlayer Weight:

The underlayer stone beneath the armor units should be about one-tenth the weight of the armor units ($W/10$) for quarystone or concrete cube armor, and about one-fifth ($W/5$) the weight of the single layer tribar armor units.

Filter Layer:

A Filter layer of granular material (gravel, quarry-run, or spalls) is required to prevent erosion and leaching of fine, sandy shoreline material from between the voids in the armor and underlayer stone. A geotextile (fabric) filter may be used instead of a stone filter.

Layer Thickness:

The thickness of the armor layer and underlayer is determined by:

$$r = nk_{\Delta} (W/w_r)^{0.33}$$

where, r = the average layer thickness in feet

n = the number of stone or concrete units comprising the layer

W = the total weight of the individual stone or concrete units in pounds

w_r = the unit weight in pounds per cubic foot

k_{Δ} = the layer coefficient

An armor layer thickness of $2n$ is generally recommended for quarystone under breaking wave conditions.

Number of Armor Units:

The number of individual stone or concrete armor units for a given surface area (N_r) can be determined by:

$$N_r = A n k_{\Delta} (1-P/100) (w_r/W)^{0.67}$$

where, A = the surface area
P = the cover layer porosity

Values of k_{Δ} and P for quarrystone, concrete cubes and tribars are as follows:

	k_{Δ}	P(%)
Quarrystone	1.00	37
Concrete Cube	1.00	37
Tribars (1 layer)	1.13	47

○ Graded riprap revetment

Graded riprap armor layers are acceptable for lower design wave heights. A general rule for graded riprap is that the design wave height should be less than 5 feet. This can be an economical design alternative if the riprap design gradation limits match the quarry-yield gradation.

Armor Layer Weight:

For graded riprap armor stone the rock weight is determined by:

$$W_{50} = w_r H^3 / [K_{RR} (Sr - 1)^3 \cot \theta]$$

The symbols are the same as previously defined. The stability coefficient, K_{RR} , for graded angular quarrystone riprap is 2.2. W_{50} is the weight of the 50 percentile size in gradation; the maximum weight is $4(W_{50})$ and the minimum is $0.125(W_{50})$. Detailed guidelines for establishing gradation limits can be found in the previously referenced design manuals.

Layer Thickness:

The minimum layer thickness for graded riprap should be **one foot** or:

$$r_{\min} = 2.0 (W_{50}/w_r)^{0.33}$$

whichever is greater. Greater layer thickness will tend to increase the reserved strength of the riprap revetment against wave attack greater than the design wave. As with larger quarrystone revetments, a stone or geotextile filter must be used under the riprap cover layer to prevent erosion of fine shoreline material from between voids in the armor.

○ Concrete block revetment

Where armor stone for revetments is not available, cast concrete blocks can be used for both the revetment armor and underlayer. Concrete blocks used on Johnston Atoll are 3 to 5-foot square at the base, 2 to 3 feet high with tapered sides, and weigh 1 to 4 tons. The underlayer blocks are 12-inch cubes, placed over a bedding and geotextile filter fabric. The concrete block revetments have been placed on a slope of 1 vertical to 3 or 4 horizontal. The performance of this revetment design at Johnston Atoll shows that the concrete block revetments are applicable in low to moderate wave height environment (i.e., less than about 3 to 5 feet).

○ Concrete rubble revetment

General guidelines for concrete rubble include:

1. Use only in low wave energy environments (i.e., design wave height less than about 3 feet), or where failure during an extreme event can be tolerated.
2. Provide a filter layer as with quarrystone or riprap. Neglect of a proper filter layer is a common cause of failure.
3. Use a thick armor of placed rubble (approximately 3 layers) instead of a single layer dumped on a slope. Each piece is shaped so that the longest dimension is no greater than three times the shortest to improve its resistance to wave attack.
4. The flatter the slope is, the more stable the rubble will be. The slope should not exceed 1 vertical on 2 horizontal.

○ Armor overlay

An existing damaged or undersized stone revetment can be upgraded using a layer of larger quarrystone or concrete armor units. The armor stone would be sized according to the design wave heights. Model tests have shown that the stability of overlays is about equal to a standard design. It is, however, only about one-half the reserve strength if the design wave height is exceeded.

Typical revetment cross-sections are shown on Figures Annex 7-1 and Annex 7-2.

3. Seawall Design

A seawall is generally a massive structure designed for high wave energy locations and to protect high value coastal property. Concrete pile-supported seawalls have been extensively used at Johnston Atoll. Typically these seawall designs consist of steel sheetpiling capped with a concrete face up to the existing ground elevation. Vertical crest sections are used as wave screens above the sloping face to reduce wave overtopping and splash over. A 10 to 15-foot wide, hard-surfaced apron has often been constructed behind the seawalls to prevent scour and loss of material from behind the walls due to overtopping waves. Regularly spaced drains are provided to collect and return overtopping water back to sea.

Masonry gravity walls are commonly used for shore protection. They are constructed of cast-in-place reinforced concrete or of individual rocks grouted in place. A gravity wall is stabilized by its own weight. Resistance to toppling seaward by the retained soil is accomplished by providing a broad base and sloping tie back face so that the resultant force of the backfill pressure is directed downward through the wall. Weep holes are provided at regular interval for drainage.

Seawalls provide an alternative to rubble mound revetments at Majuro Atoll, particularly for high risk areas or where stone is not available. Typical seawall cross-section are shown on Figure Annex 7-3.

Figure Annex 7-1

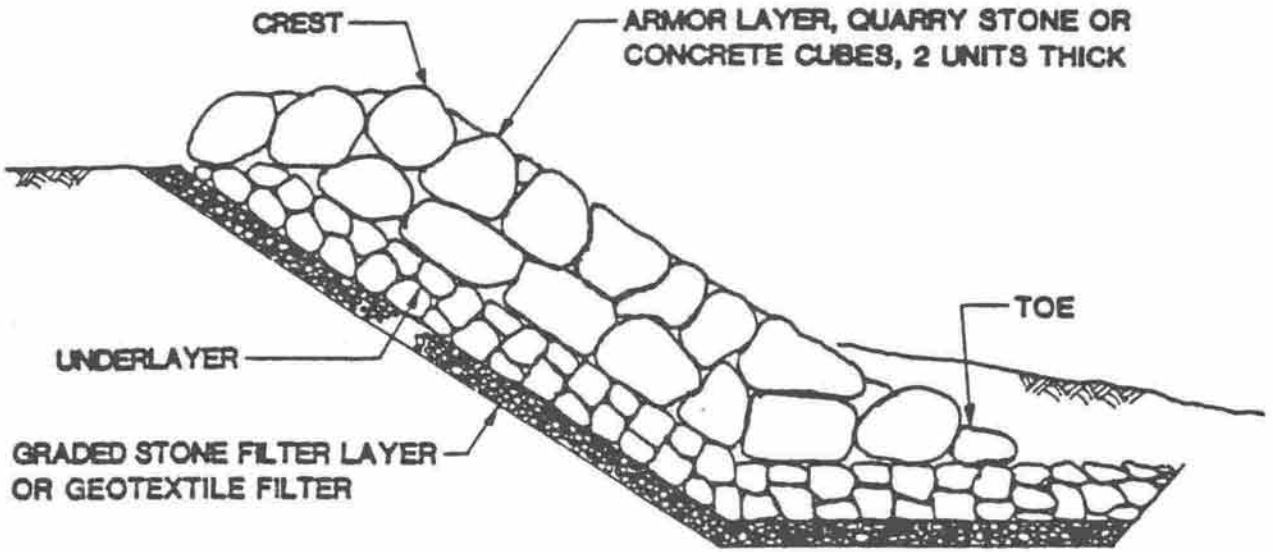

NOTE: UNDERLAYER AND FILTER BENEATH THE TOE NOT REQUIRED WHEN ARMOR RESTS ON REEF ROCK

QUARRY STONE OR CONCRETE CUBE ARMOR

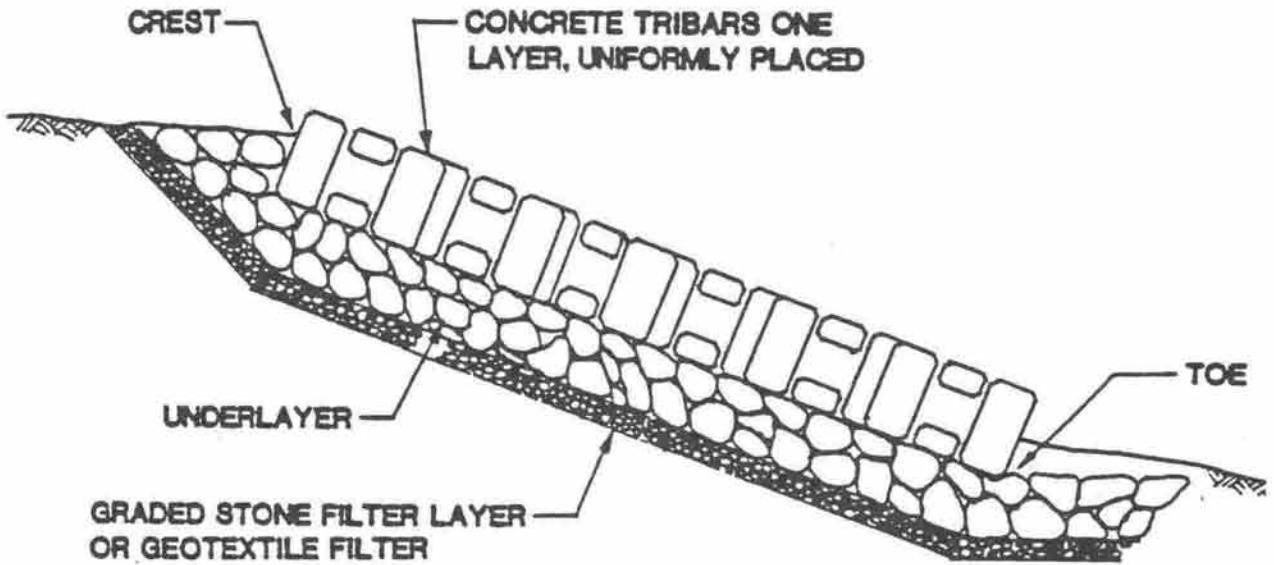

NOTE: UNDERLAYER AND FILTER BENEATH THE TOE NOT REQUIRED WHEN ARMOR RESTS ON REEF ROCK

CONCRETE TRIBAR ARMOR

TYPICAL RUBBLE MOUND REVETMENT CROSS SECTION FOR HIGH LEVEL OF PROTECTION

Figure Annex 7-2

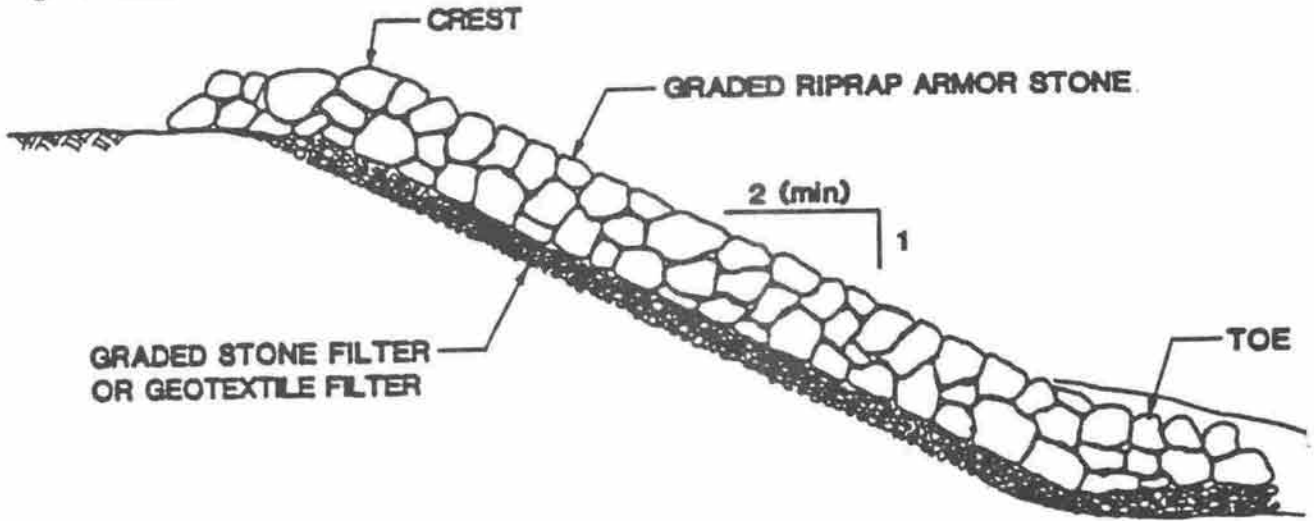

RIPRAP REVETMENT (WAVE HTS < 5 FT)

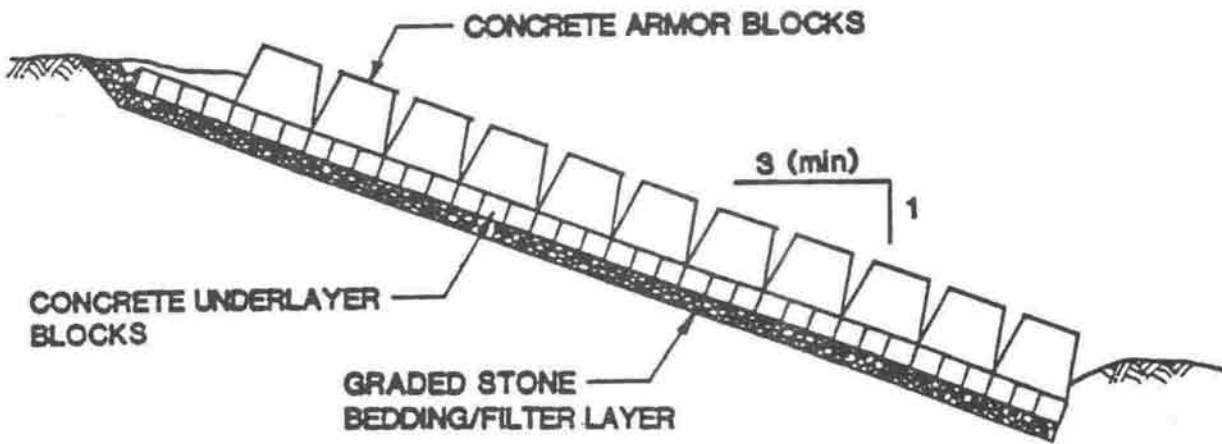

CONCRETE BLOCK REVETMENT (WAVE HTS < 3-5 FT)

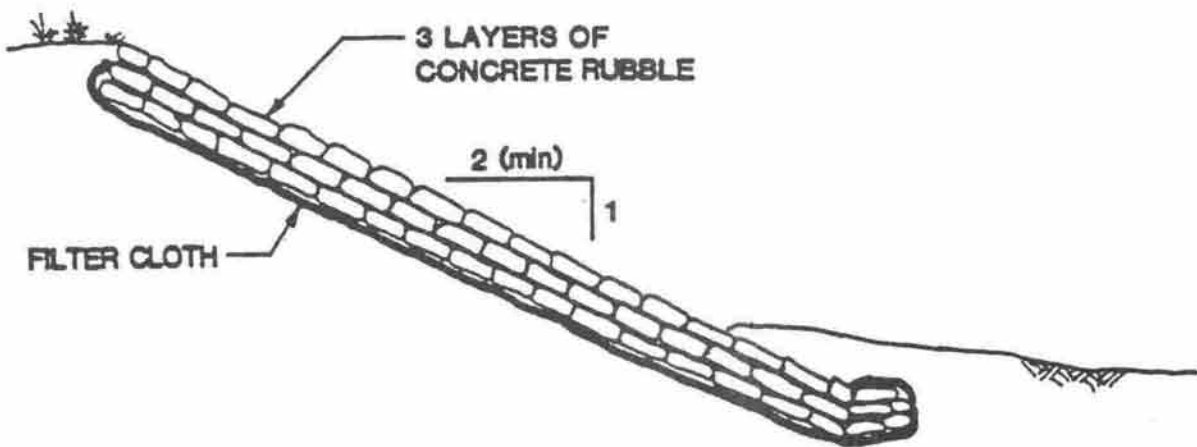

CONCRETE RUBBLE REVETMENT (WAVE HTS < 3 FT)

TYPICAL REVETMENT CROSS-SECTION FOR LOW TO MODERATE LEVEL OF PROTECTION

Figure Annex 7-3

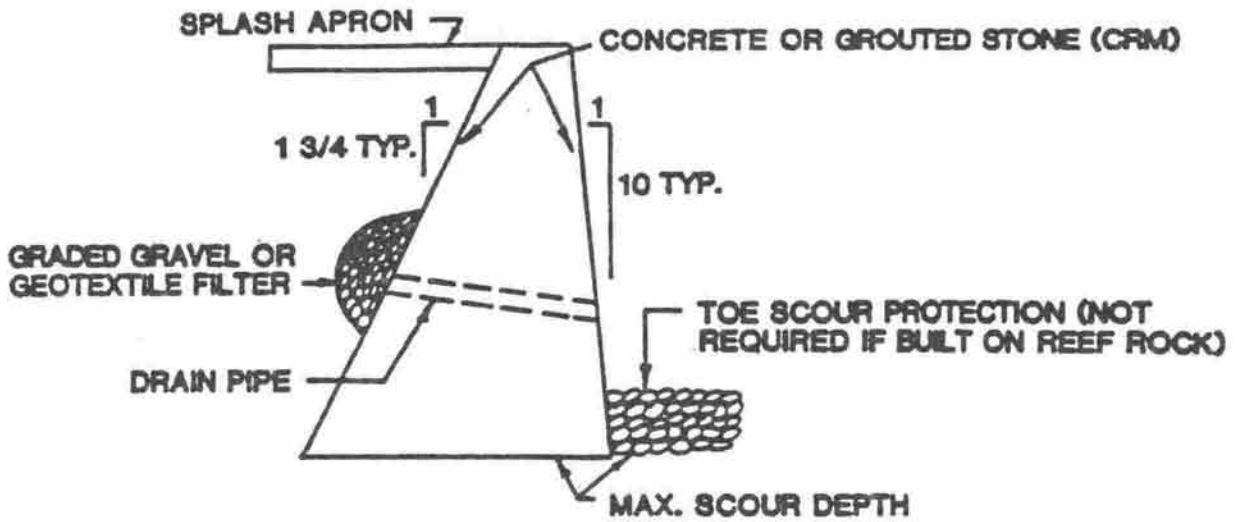

CONCRETE OR GROUTED MASONRY (CRM) GRAVITY SEAWALL

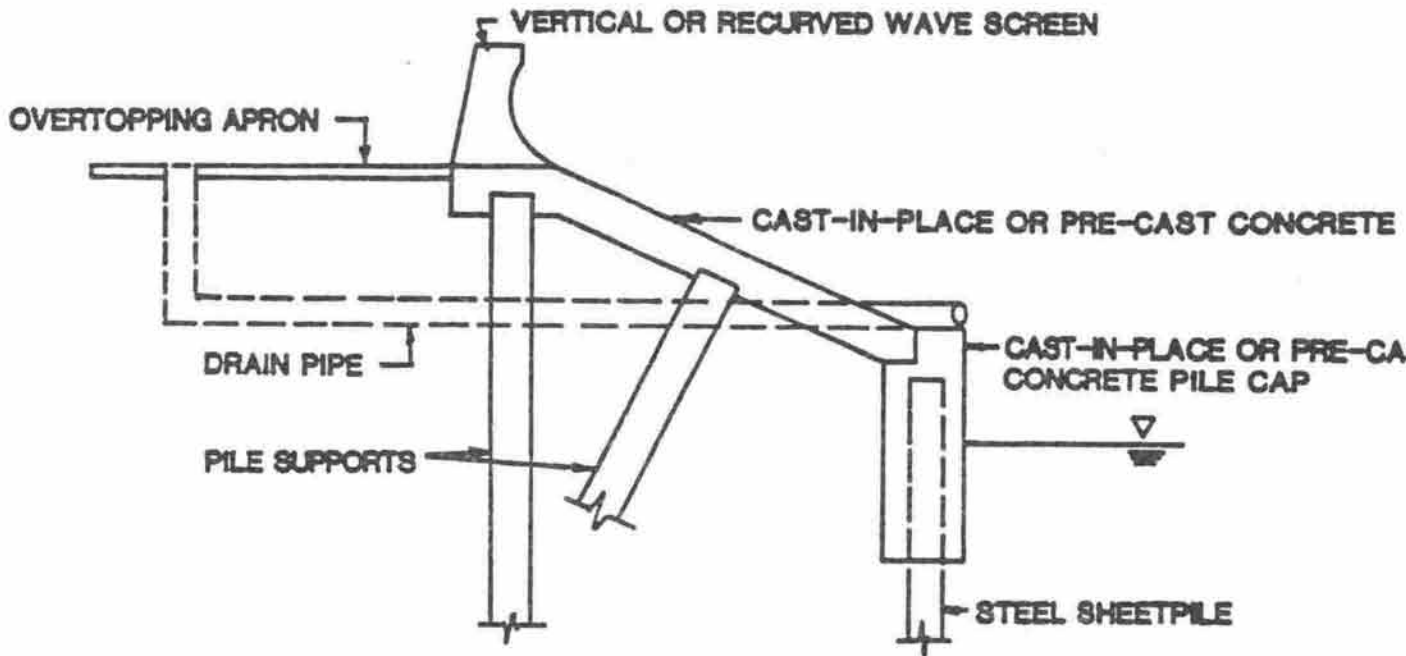

SLOPING PILE-SUPPORTED CONCRETE SEAWALL

TYPICAL SEAWALL CROSS SECTIONS

○ Coastal Flood Protection

Where wave runup exceeds the crest elevation of the foreshore land, wave overtopping and flooding of the backshore area occurs. Protection against flooding damage by overtopping waves can be accomplished by; (1) constructing adequate shore protection with a non-overtopping crest elevation for the desired design conditions; (2) constructing a wall or berm above the existing shoreline or shore protection crest to prevent overtopping during infrequent but severe storm wave attack, or (3) providing a scour-resistant surface behind the shoreline crest and grading the backshore for proper drainage during overtopping conditions.

Where shore protection is required it is generally preferable to design structures high enough to preclude overtopping. Sometimes, however, prohibitive costs or other considerations may result in lower shore protection structure crest elevations than needed to prevent overtopping during extreme conditions. Overtopping wave walls (screens) can be constructed as gravity walls or pile-supported walls, using concrete-rubble masonry, cast-in-place concrete or precast concrete elements. The SPM (1984) contains detailed methodology for calculating the wave forces and the moments exerted by broken waves on a wall located shoreward of the design stillwater line. These walls usually can prevent severe overtopping by "green" water. However, considerable splash over is still likely to occur, particularly with strong onshore winds.

During overtopping situations damage to the backshore immediately behind a shore protection structure can be reduced or eliminated by constructing a scour resistant surface of concrete, asphalt or stone. Coupled with a drainage system the scour protection can prevent the damage that could lead to significant damage to the structure itself. The drainage control is also an effective means for reducing damage and flooding of the backshore area during overtopping conditions. Properly graded slopes and drainage channels can reduce the inundation limits and hasten the dewatering of flooded areas.



