

Potential Alternatives for Key Technologies to Improve the Accuracy and the Lead-Time of Flood Forecasting in the Mekong River

Kazuhiko FUKAMI, M.Levent KAVVAS and Riko OKI

- 1) International Centre for Water Hazard and Risk Management (ICHARM), Public Works Research Institute, Japan
- 2) University of California at Davis, USA
- 3) Japan Aerospace Exploration Agency (JAXA), Japan



Flood disaster mitigation through flood forecasting and warning

1. Monitoring of meteorological & hydrological conditions
2. Flood forecasting
 - ✓ Correlational approach
 - ✓ Rainfall forecast & runoff analysis
3. Analysis of forecasts and judgement of hazardous risk
4. Dissemination of warning
5. Crisis management
(flood fighting, evacuation, etc.)



Flood disaster mitigation through flood forecasting and warning

(Typical situations in developing countries)

1. **Monitoring of meteorological & hydrological conditions**
 - ×Low density of gauging stations, low sustainability of maintenance of observatories, lack of historical hydrologic database, etc.
2. **Flood forecasting**
 - ×Lack of real-time hydrologic data, therefore difficult to construct and run forecasting & warning system
3. **Analysis of forecasts and judgement of hazardous risk**
 - ×Lack of historical hydrologic & statistical data of flood events and damages, therefore difficult to judge hazardous risk compared with real-time information and/or simulations, etc.
4. **Dissemination of warning**
 - ×Lack of disaster-management community and communication network, incompatibility of flood information with local society and needs, etc.
5. **Crisis management (flood fighting, evacuation, etc.**
 - ×Improper governance, insufficient institutional cooperation, etc.



Technical issues for flood forecasting in poorly-gauged or ungauged basins

1. How to acquire quasi-real-time hydrologic monitoring data (rainfall, water level and/or flood discharge)?
2. In the case of the use of precipitation-runoff modeling,
 - How to make rainfall forecast?
 - How to prepare the datasets to build a flood forecasting model? (tuning of model parameters & their verifications)
3. How to identify the degree of flood hazard risk without any real observational data on flood situations?

Current research activities and future subjects at PWRI/ICHARM in relation to flood forecasting

1. Development of satellite-based global real-time rainfall map for flood forecasting and warning on a river basin scale (with JAXA and CREST/GSMaP group)
2. Development of rainfall forecasting system for ungauged basins (with UCD)
3. Development of a common basis for quick & efficient implementations of flood forecasting and warning systems even in poorly-gauged basins (with private sectors)
4. Development of a guideline for flood warning dissemination to meet local flood-plain needs in different natural/social/monitoring
5. Development of a guideline for integrated flood management combined with other structural & non structural measures

[1]

Global rainfall estimation through satellite data

Cooperative research
between PWRI/ICHARM and JAXA (in plan)

Examples of global products of satellite-derived precipitation

Product name	3B42RT	CMORPH			
Builder	NASA/GSFC	NOAA/CPC			
Coverage	50N ~ 50S	60N ~ 60S			
Spatial resol.	0.25°	8km	0.25°	0.25°	0.5°
Temporal resolution	3 hours	30 minutes	3 hours	1 day	3hours
Delay of data delivery	10 hours	15 hours			
Timing of data updating	Every 3 hours (UTC)	Every 30 min. (UTC)	Every 3 hours (UTC)	Every one day (UTC)	Every 3 hours (UTC)
Coordinate system	WGS				
Data archive	Dec. 1997 ~	Recent 4 days	Dec. 2002 ~	Jan. 2004 ~	Dec. 2002 ~
Data source	TRMM-TMI, DMSP-SSM/I, Aqua-AMSR-E, AMSU-B and IR	DMSP-SSM/I, TRMM-TMI, Aqua-AMSU-B, and IR			

Example of satellite-based rainfall product

- 3B42RT (NASA)
 - Temporal resolution: 3hr (snap shot)
 - Spatial resolution: 0.25 deg. ~ 25km

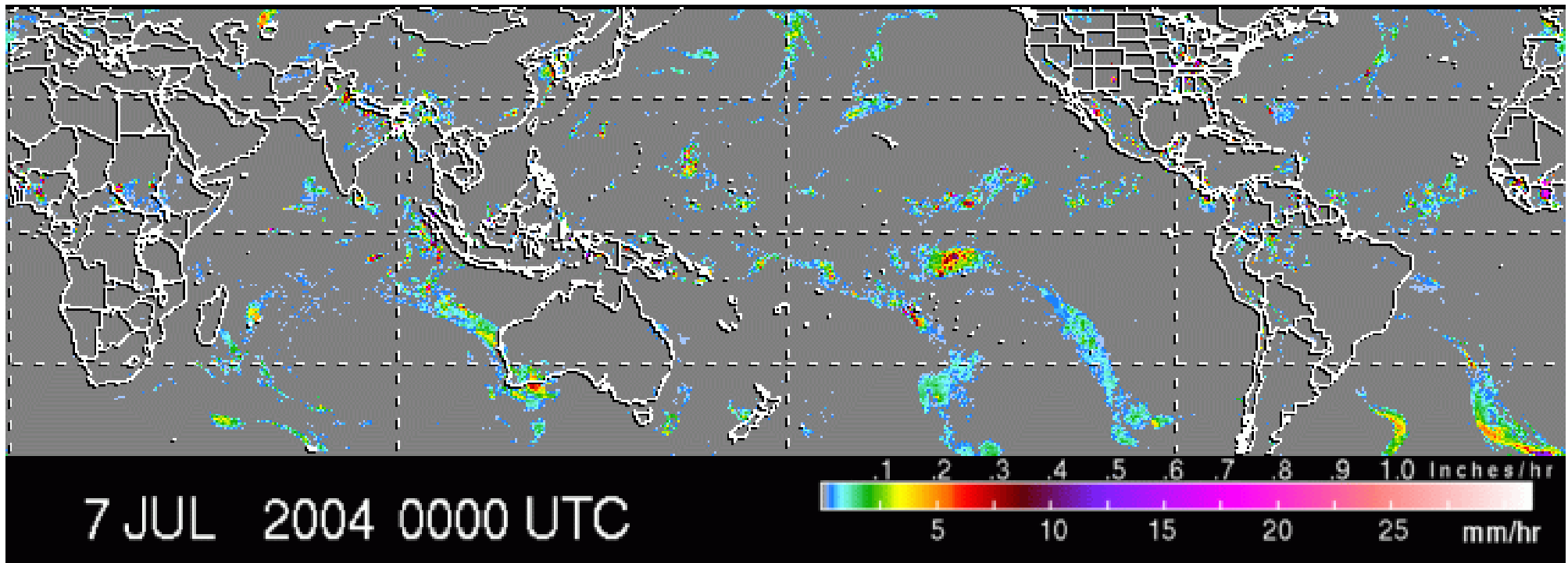

Global Flood Alert System (GFAS)

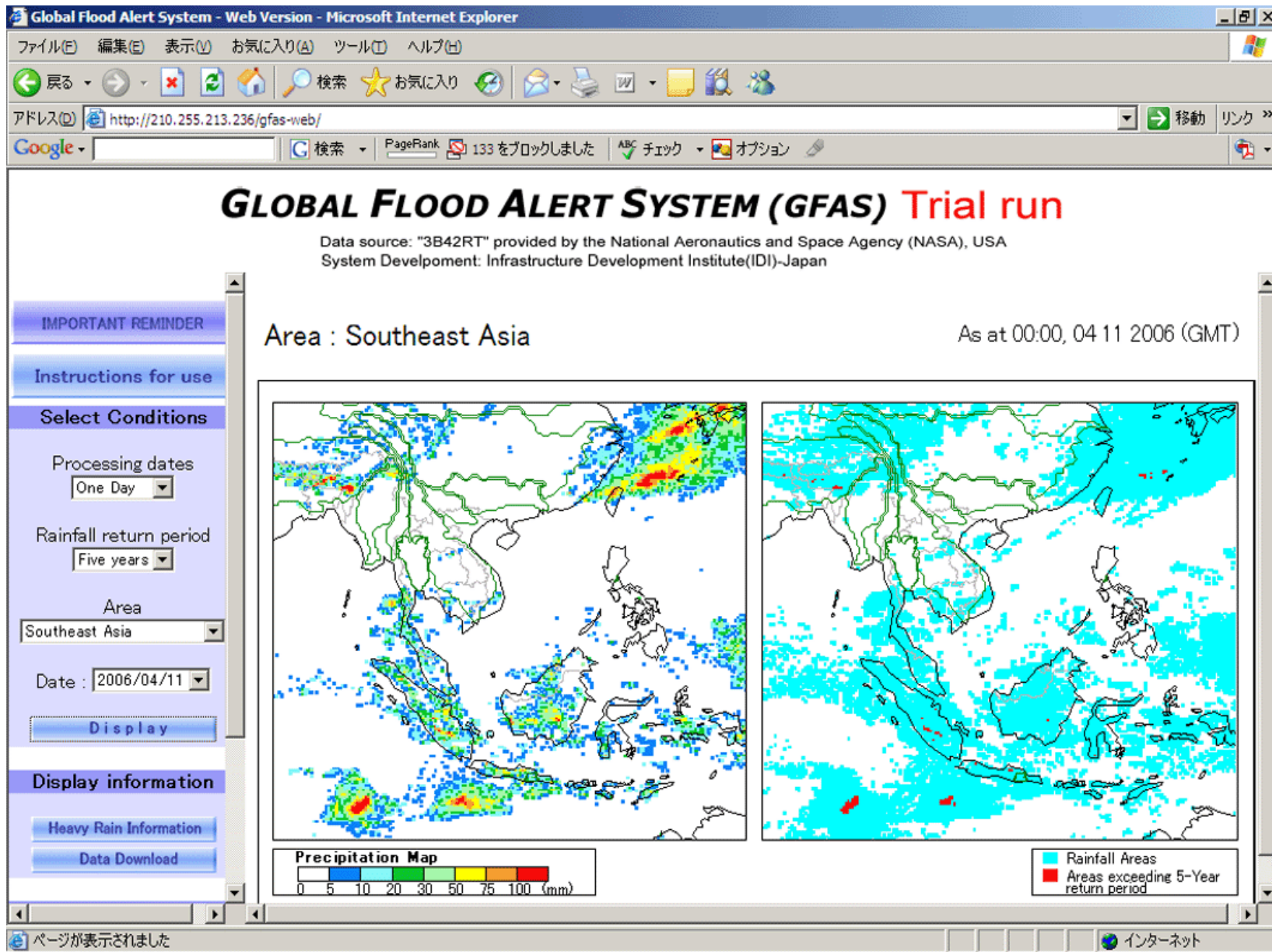

A case study at the Kitakami –Gawa River runoff calculation ($A=2,000 \sim 7,500\text{km}^2$)

Use TRMM-derived 3-hourly rainfall distribution (2.5deg.) as input

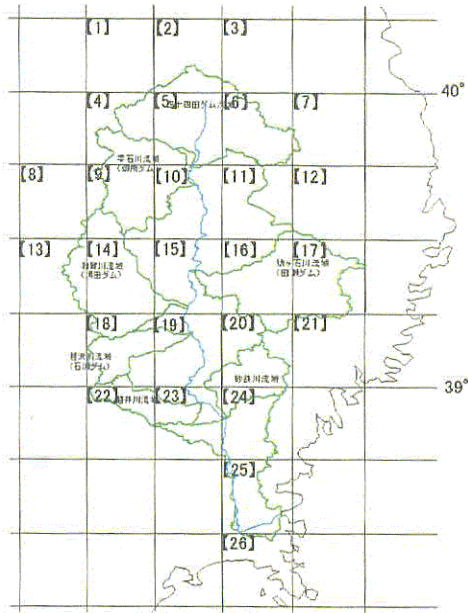

Kitakami River Basin
divided by 0.25° grid mesh

3rd biggest flood after WW2

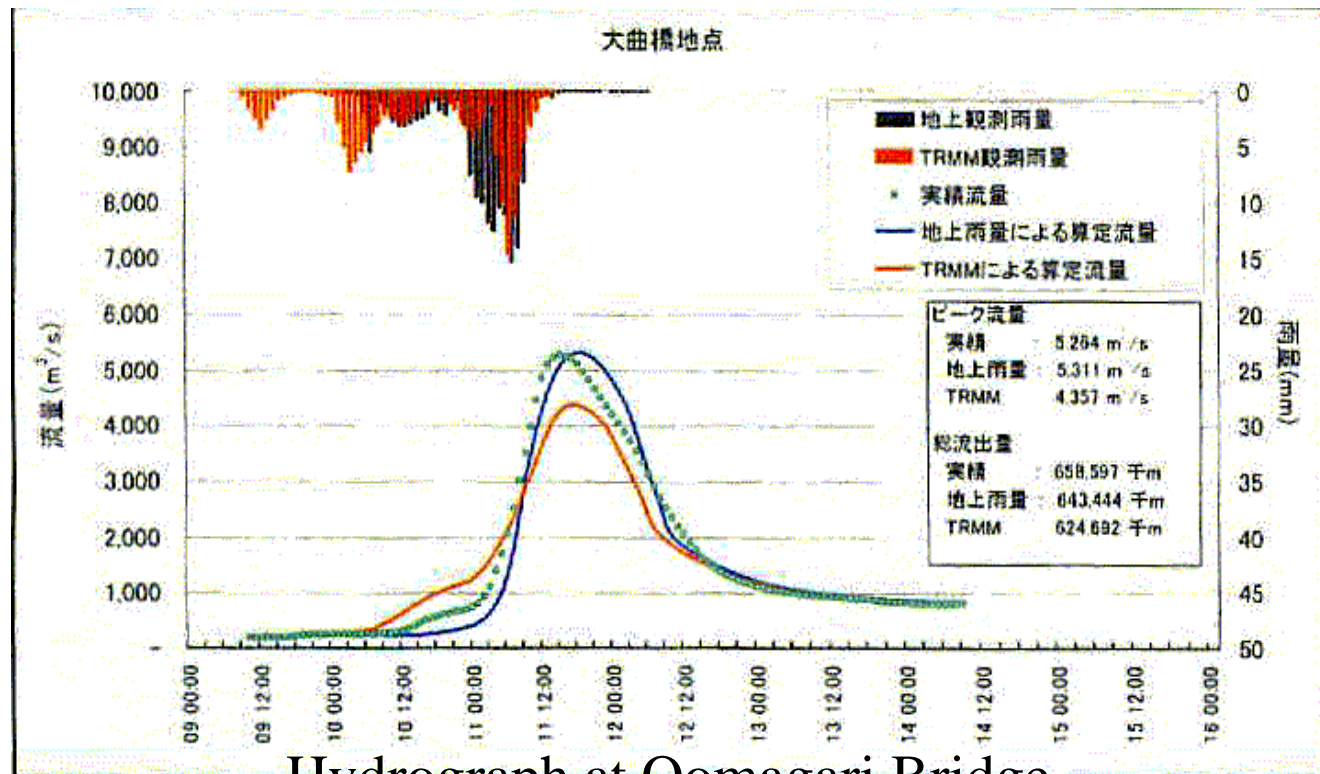
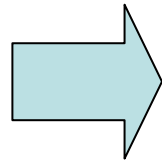

Hydrograph at Oomagari Bridge

Relative error of $Q_{\text{peak}} = 17\%$
Relative error of $Q_{\text{total}} = 5\%$

Source:

MLIT & IDI,
Japan

Outline of Global Precipitation

Measurement (GPM)

- Scheme of establishment in observing global precipitation every 3 hours with the main satellite and 8 constellation satellites
- Japan's contribution: Development of dual precipitation data and launch of H2-A Rocket

Core Satellite

Dual Frequency Radar
Multi Frequency Radiometer

- ◇ Observation of rainfall with more accurate and higher resolution
- ◇ Adjustment of data from constellation satellites

JAXA (Japan)

Dual frequency Radar, Rocket

NASA(US)

Satellite Bus, Micro-wave gauging measurement

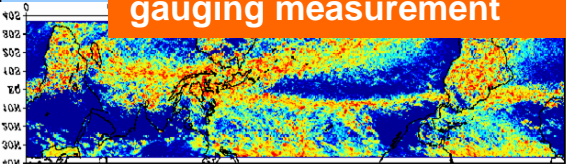

Constellation Satellites

Satellites with Micro-wave Radiometers

- ◇ More frequent Observation

Cooperation :

NOAA(US), NASA(US), ESA(EU), China, Korea and others

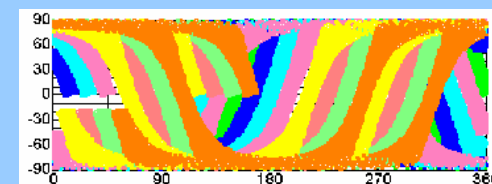

–Earth heating Phenomena

–Study of Climate Change

–Improvement of forecasting system

Global Observation every 3 hours

●IWRM

●Flood Forecasting

●Forecasting of crop productivity

JAXA-PWRI Cooperative Research (in plan)

- Title: Study on the improvement of the accuracy of satellite-derived rainfall estimation for flood forecasting and its applications under GPM
- Target:
 - Time resolution: 1hr
 - Spatial resolution: 10km
 - Improvement of rainfall estimation and forecast over land area



The Global Satellite Mapping of Precipitation (GSMaP) Project

- Development of high-resolution satellite-derived precipitation map
- Lead by Prof. Ken'ichi OKAMOTO and GSMaP team
- GSMaP is supported by the CREST program, funded by Japan Science and Technology Agency (JST)

GSMaP V4.6 TMI: Comparison of Zonal Average (Land)

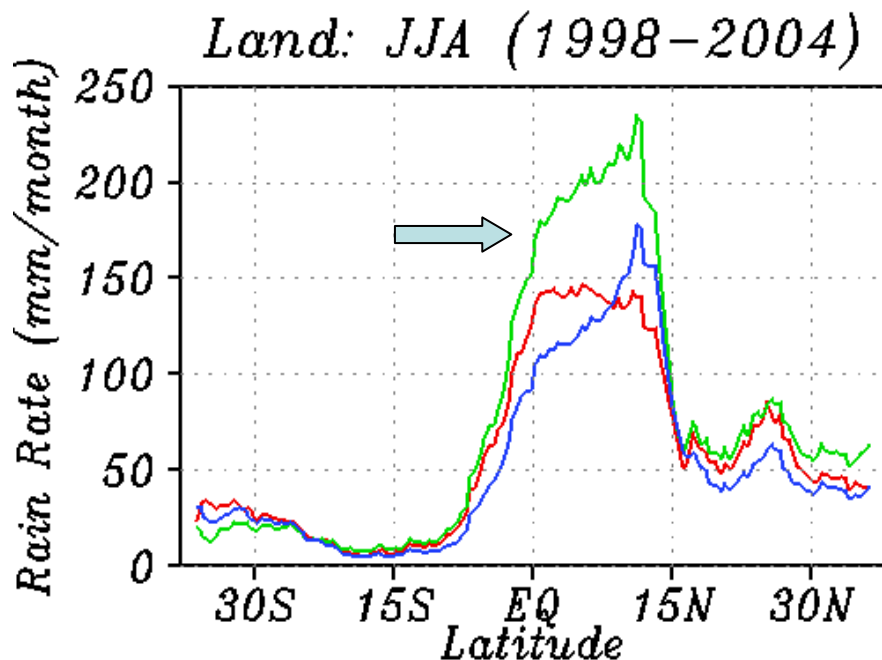
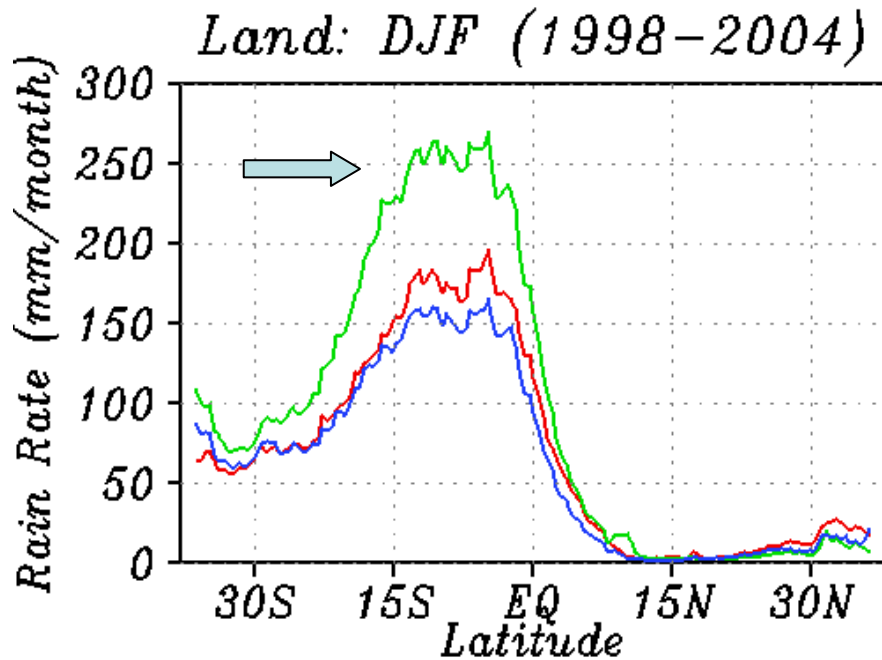

PR V6
GPROF V6 TMI
GSMaP V4.6 TMI

- GPROF overestimates rain rates over land in the tropical raining area.
- GSMaP follows the PR well, although GSMaP tends to underestimate.

Courtesy of Prof. Ken'ichi Okamoto and GSMaP team

Collaboration among JAXA, PWRI/ICHARM and GSMP team

- Expected cooperative research plan between JAXA and PWRI, in collaboration with GSMP team led by Prof. Okamoto. Current targets are;
 - to validate GSMP algorithm as an input to flood monitoring/forecasting system; and
 - to develop proto-type system for producing NRT rainfall map using GSMP algorithm that suits to flood monitoring/forecasting.
- PWRI/ICHARM will develop an Integrated Flood Analysis System (IFAS) with private sectors under the condition such high-resolution (in time and space) satellite-based rainfall products are available.

Planned Specifications of GSMap-based JAXA-PWRI/ICHARM Global Precipitation Map (draft)

Input data	Microwave data (Aqua/AMSR-E, TRMM/TMI, SSM/I), IR data(GMS-IR), GANAL, SST
Time resolution	1hr
Delivery time	less than 4 hours after satellite data acquisitions
Spatial resolution	0.1°×0.1°
Observational range	60°N ~ 60°S

Example of Proto-type of Global Precipitation Map

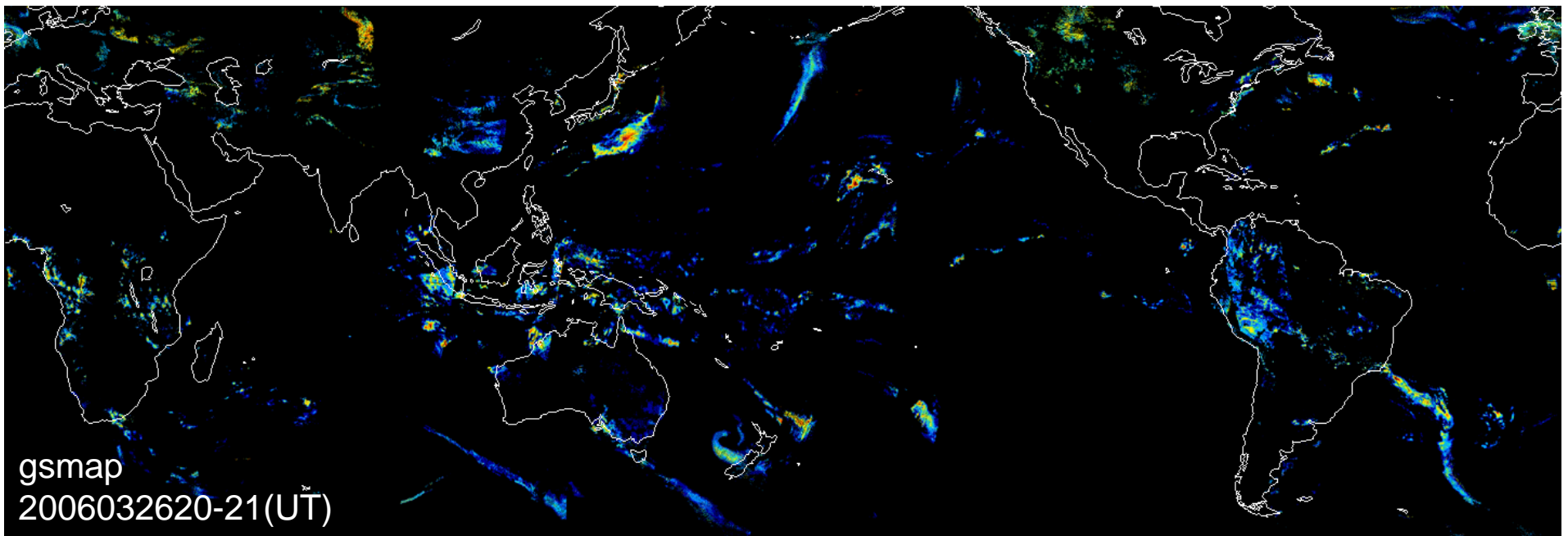
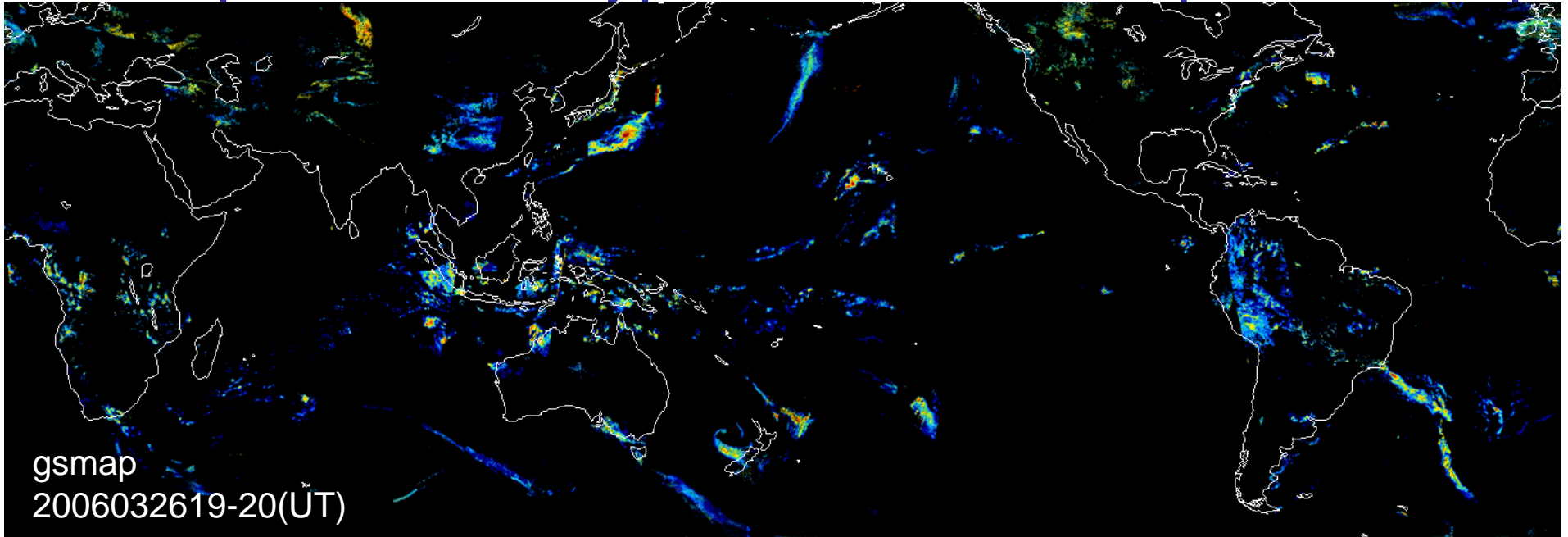

[2]

Rainfall forecasting
based on
downscaling technology through
mesoscale numerical
atmospheric model

Cooperative research
between PWRI/ICHARM
and University of California, Davis, USA

Numerical Downscaling of GCM/Reanalysis Results by Regional Climate Models

- GCM & reanalysis results form initial and boundary conditions for regional hydroclimate model
- Regional model has more refined topographic and land surface characteristics data

There are several regional-scale climate models (RegCM) used for downscaling studies.

UCD-PWRI Integrated Regional-Scale
Hydrologic/Atmospheric Model
(**IRSHAM**)

studied the impact of climate change on the
hydrologic regime of
a region (continental/country scales) at Japan,
Korea and California
in 1990's

Regional Land Surface Hydrology Model Component in UCD-PWRI IRSHAM:

- Interception
- Areally averaged evapotranspiration, sensible heat flux, and short wave/long wave radiation equations for computation of these fluxes as areally-averaged quantities at each grid area;
- Areally averaged soil water flow and soil heat flow equations
- Computes infiltration, exfiltration, soil water content profile, soil water storage, direct runoff volume, soil temperature as areally-averaged quantities at each model grid area

Land Surface Processes

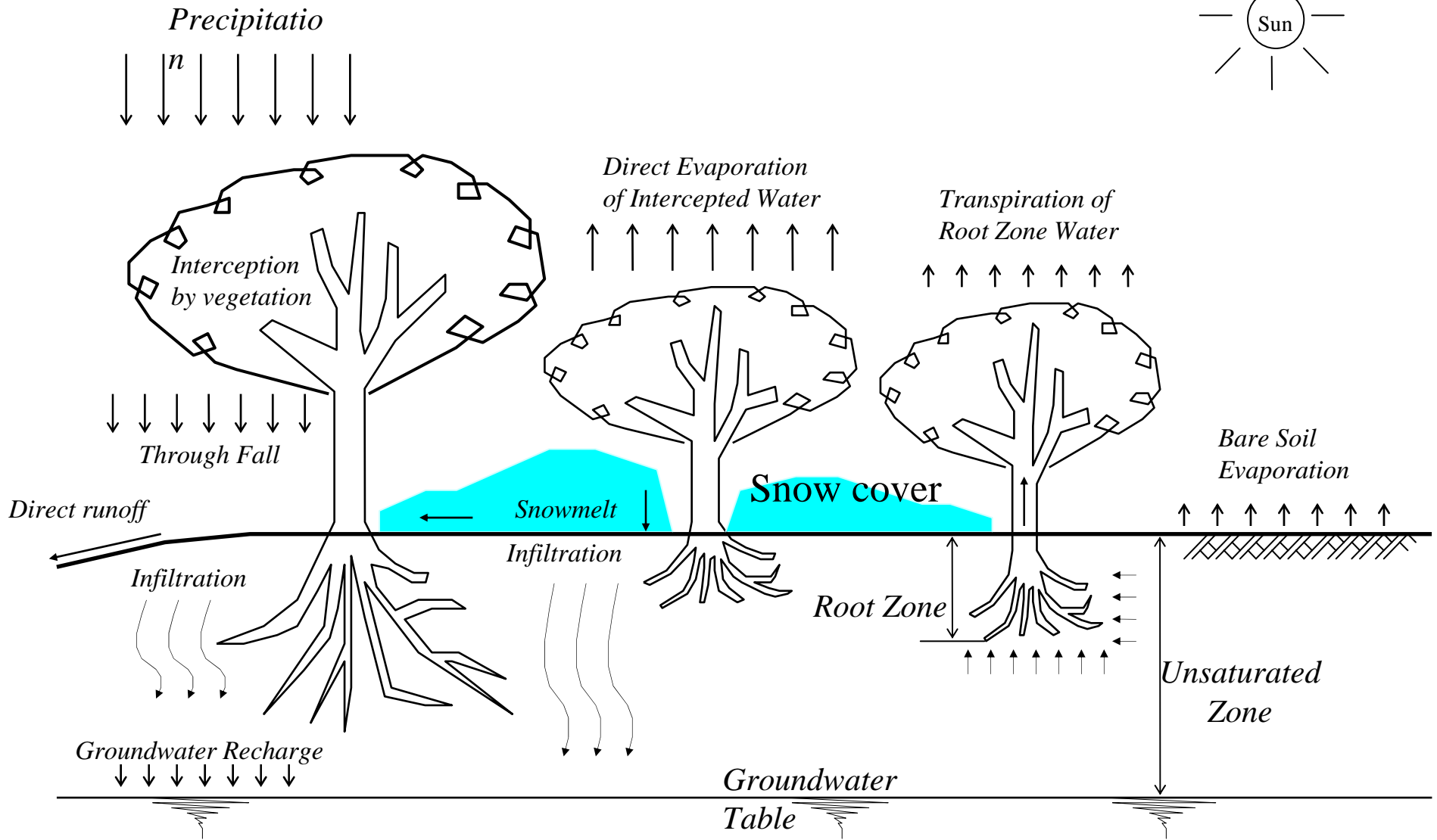
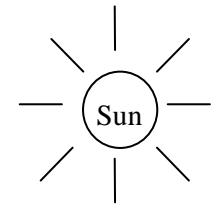

Concept of areally-averaging soil water profiles in a computational mesh in UCD-PWRI IRSHAM

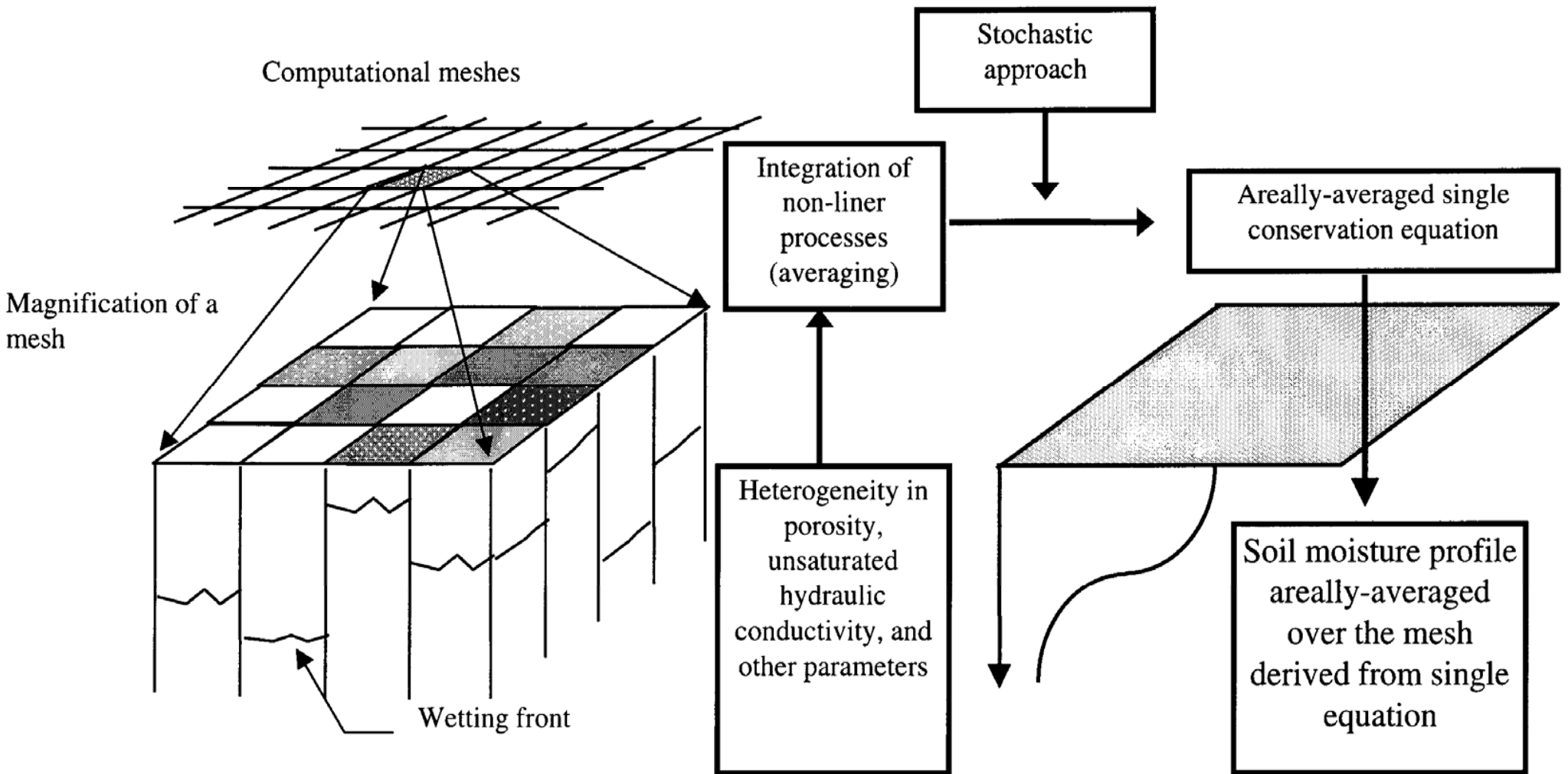

Reconstruction simulations were performed by
Regional Hydroclimate Model (RegHCM)

which is formed **from the coupling of**
NCAR/MM5 atmospheric model and

the land hydrology component of UCD-PWRI IRSHAM.

No calibration, nor optimization (MM5 modeling options at default).

Also, no filtering (nor nudging) was performed for updating.

Models' parameters were taken at default values. In the case of
landsurface parameters, models' parameters were estimated directly
from World land data sources that are available all over the World at
1km spatial resolution.

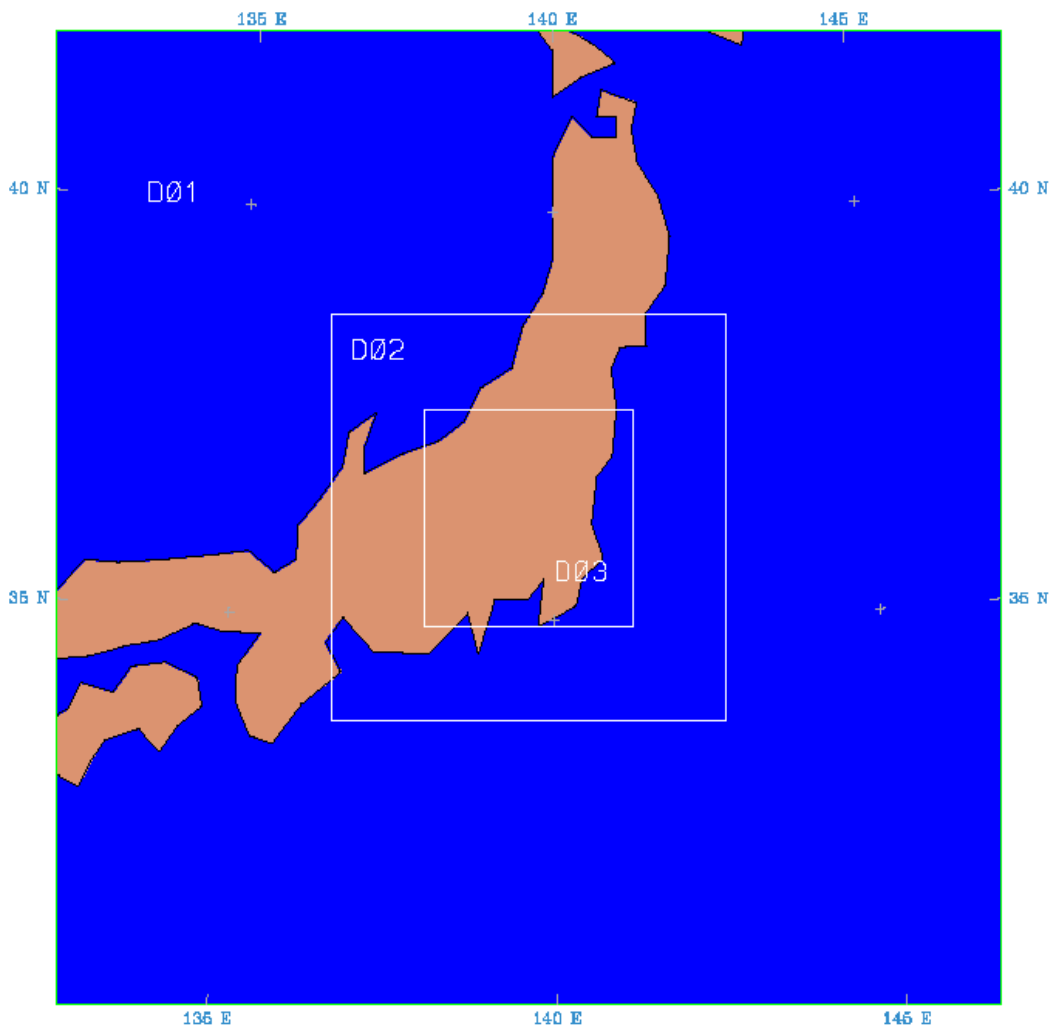

 Tone River Basin
 Ara River Basin

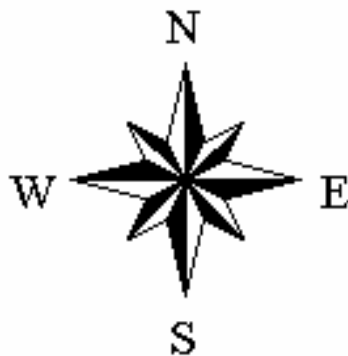

Monthly Precipitation Reconstruction for May 1996 at the Tone-Arakawa River Basins

Observed Monthly Precipitation 1996_5

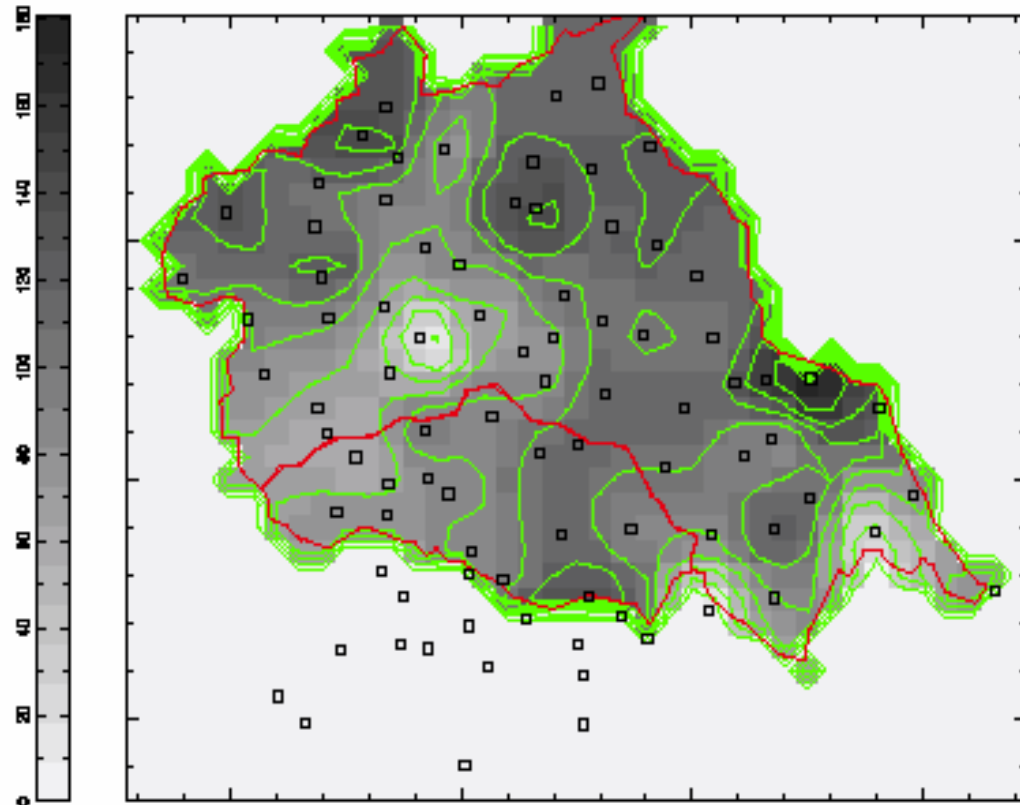

Simulated Monthly Precipitation 1996_5

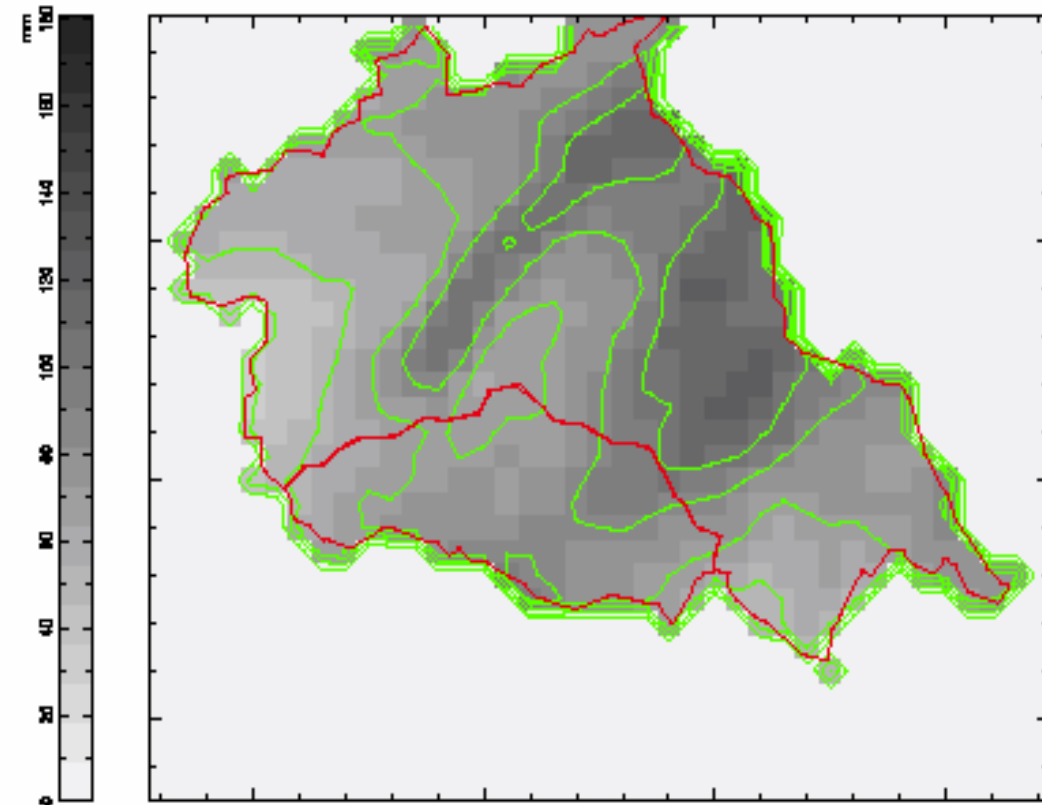

Computational domain and locations of weather stations

Upper Domain For Reconstruction

- Mekong River Basin
- HYMOS stations
- NCAR stations

Lower Domain For Reconstruction

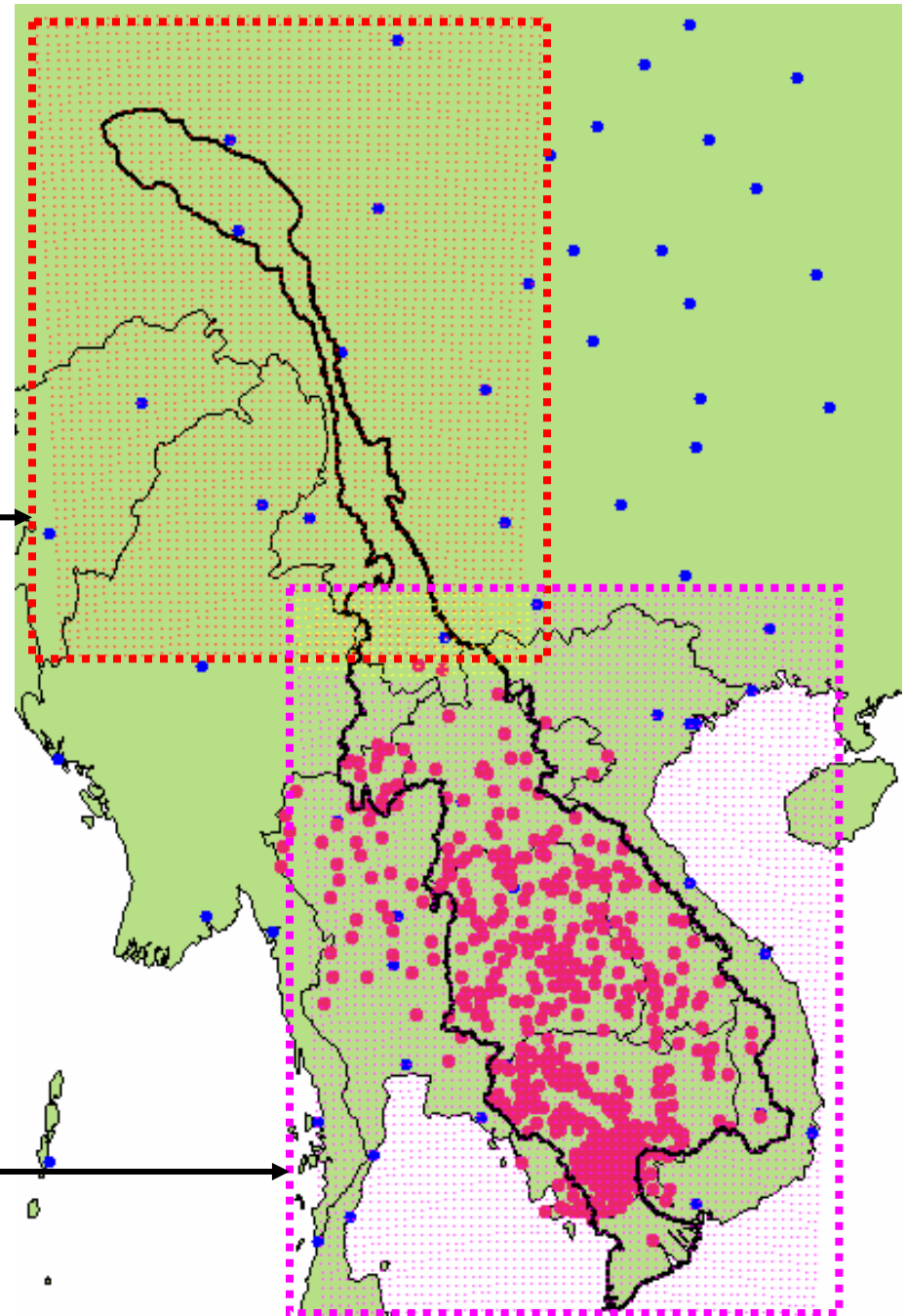

Processing of gauged precipitation data

After the data qualification process,
1304 HYMOS stations and
75 NCAR stations
 remain around Mekong River
 watershed.

**Inverse distance interpolation
 with distance (support size) limit**
 is applied to both monthly
 observed datasets in order to
 capture the local variability of
 precipitation distribution.

Since the observation periods of
 the stations are different, the no-
 data area varies for each image.

July 1995 (for example)

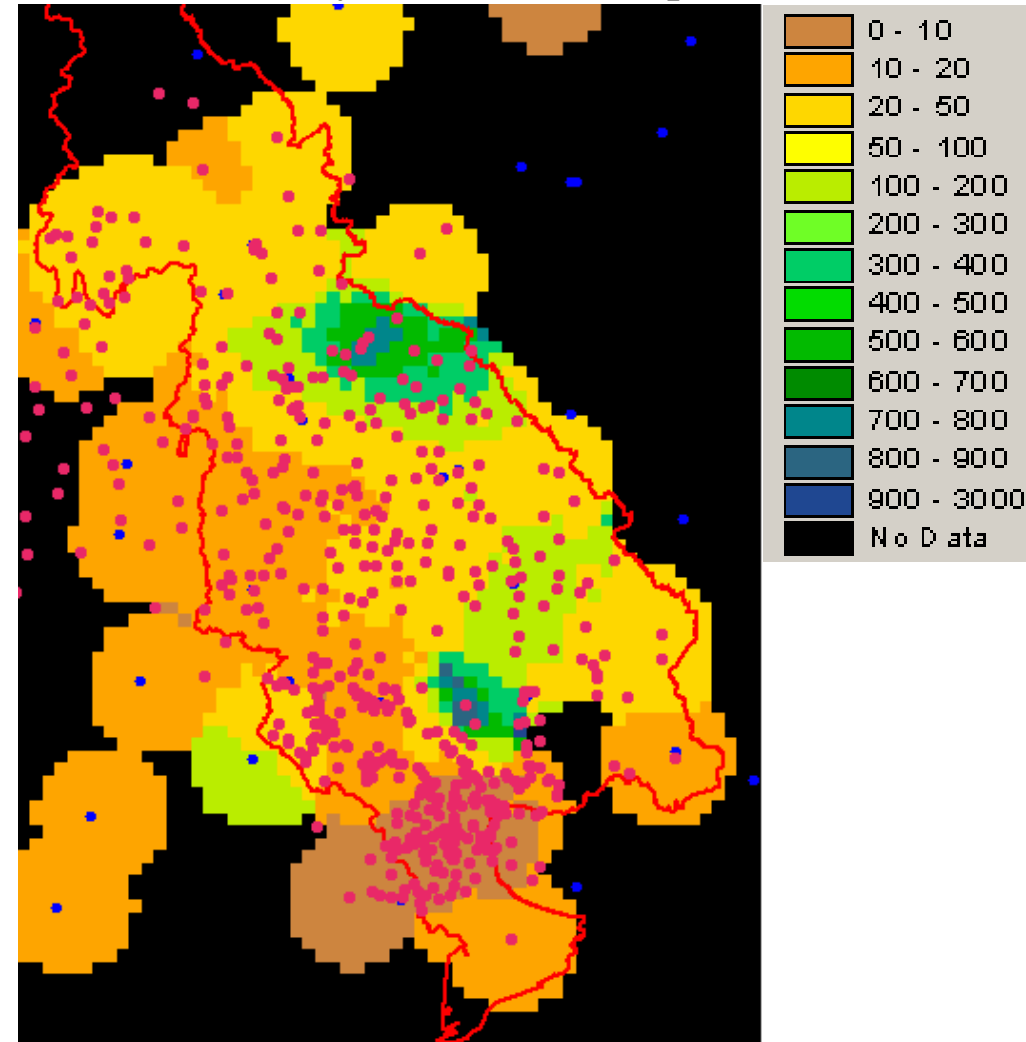

Mekong River Basin
• HYMOS stations
• NCAR stations

Area average of annual observed precipitation around Lower Mekong River Basin

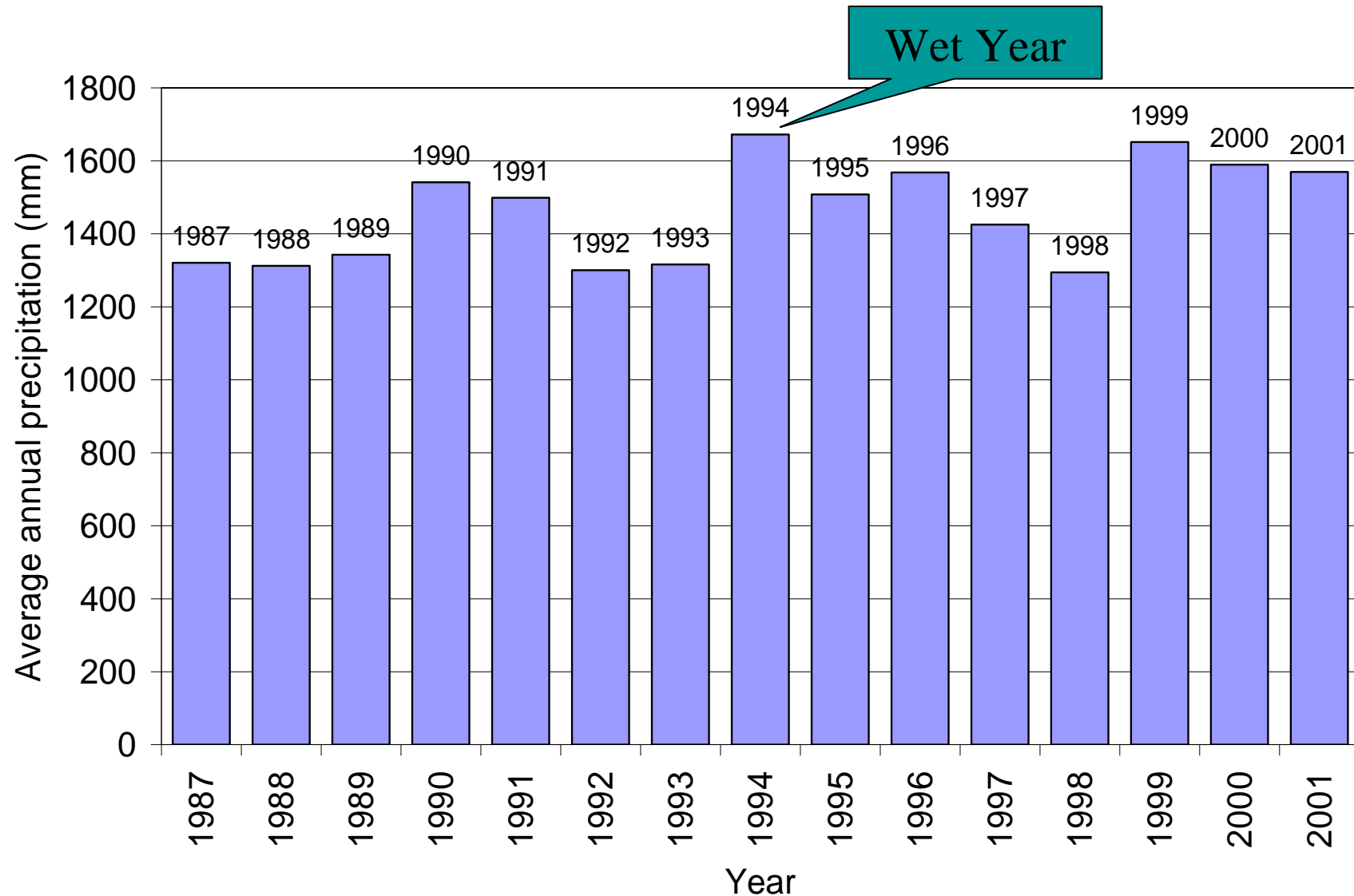

Observed and simulated monthly precipitation (mm) over the Lower Mekong River watershed in January 1994.

Interpolated surface observation

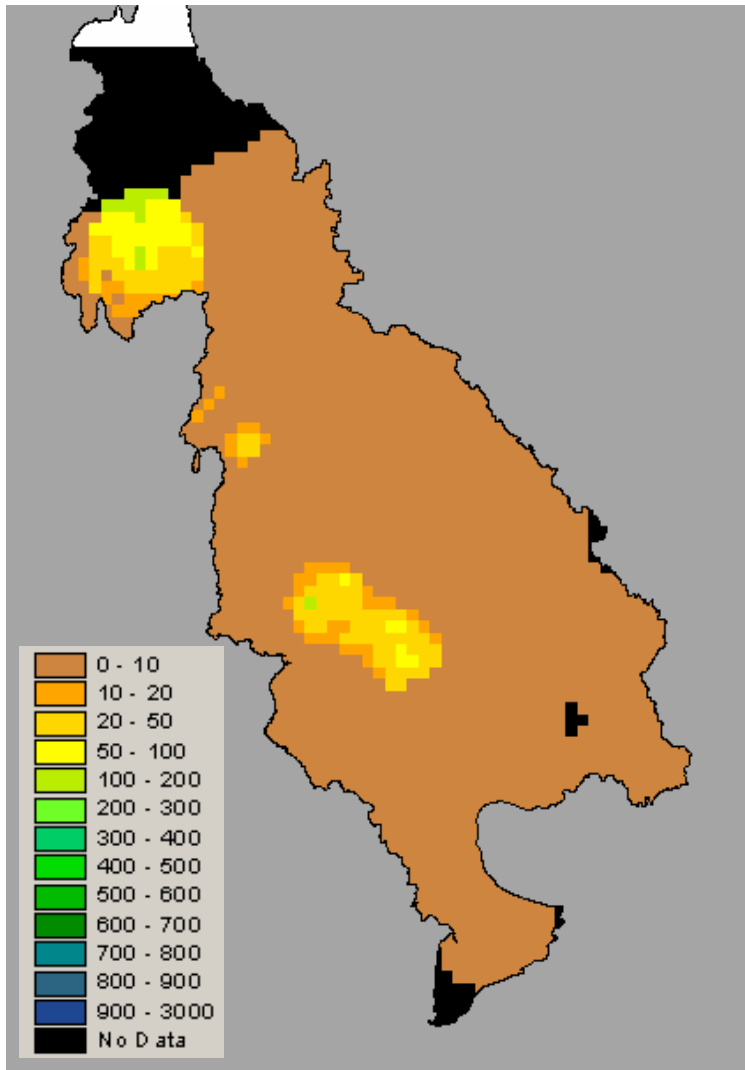

Reconstructed monthly precipitation

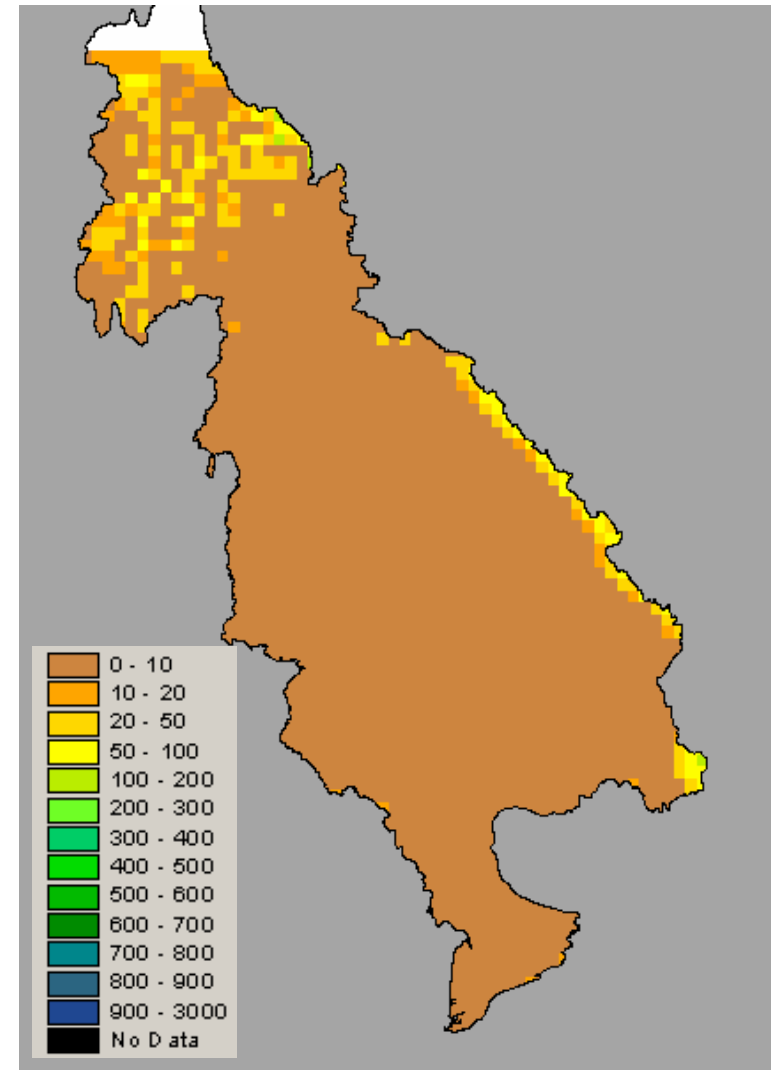

Observed and simulated monthly precipitation (mm) over the Lower Mekong River watershed in April 1994.

Interpolated surface observation

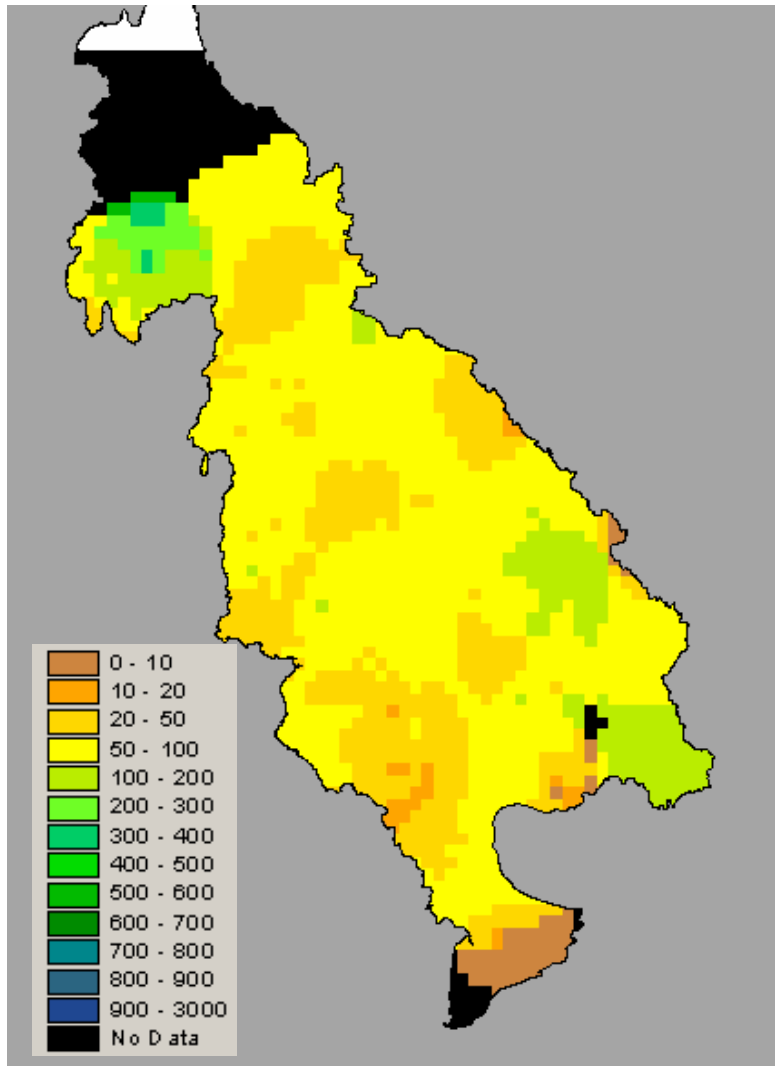

Reconstructed monthly precipitation

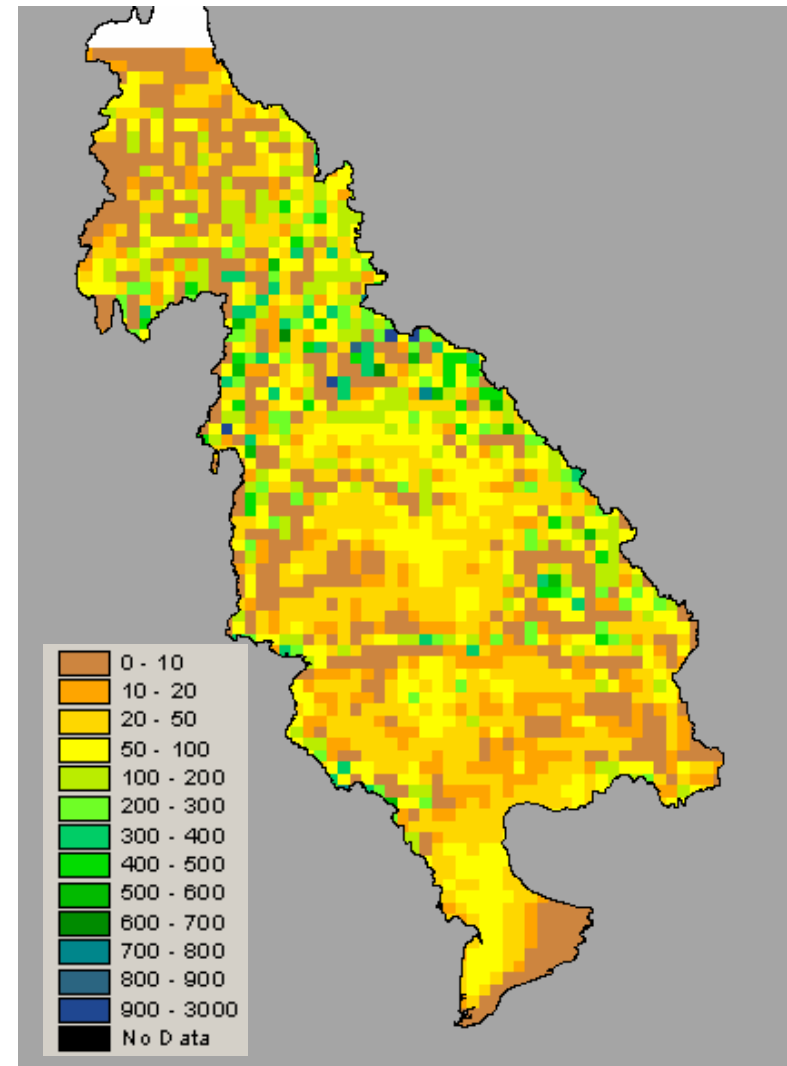

Observed and simulated monthly precipitation (mm) over the Lower Mekong River watershed in July 1994.

Interpolated surface observation

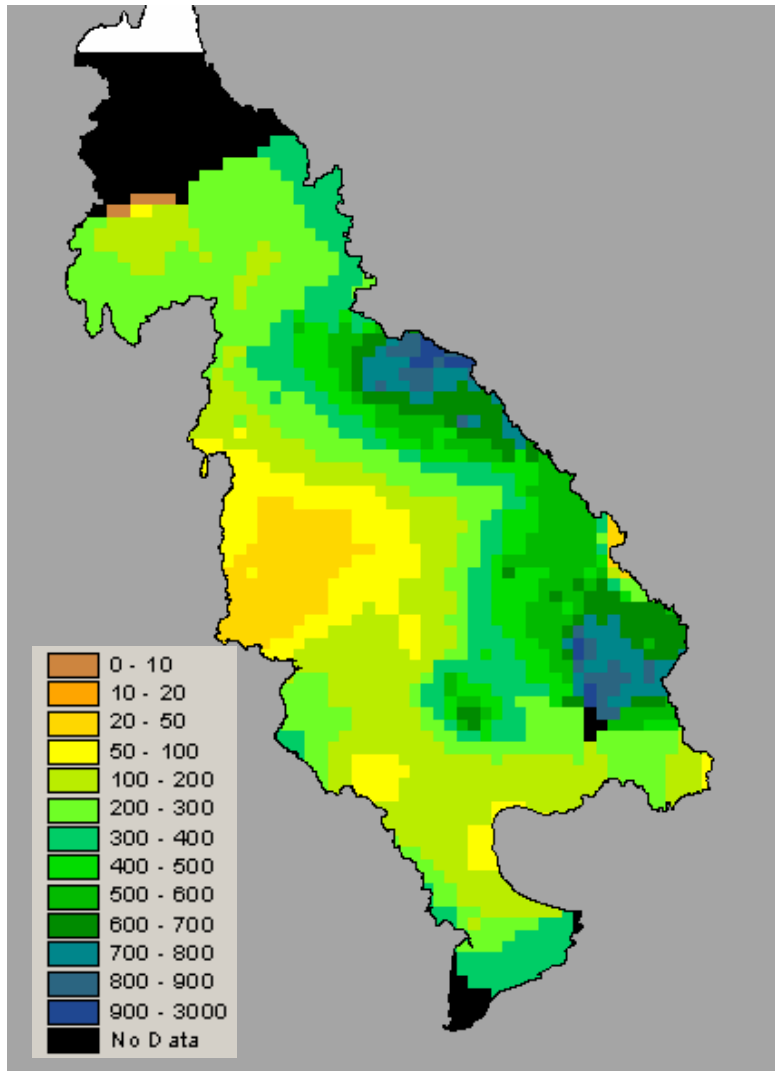

Reconstructed monthly precipitation

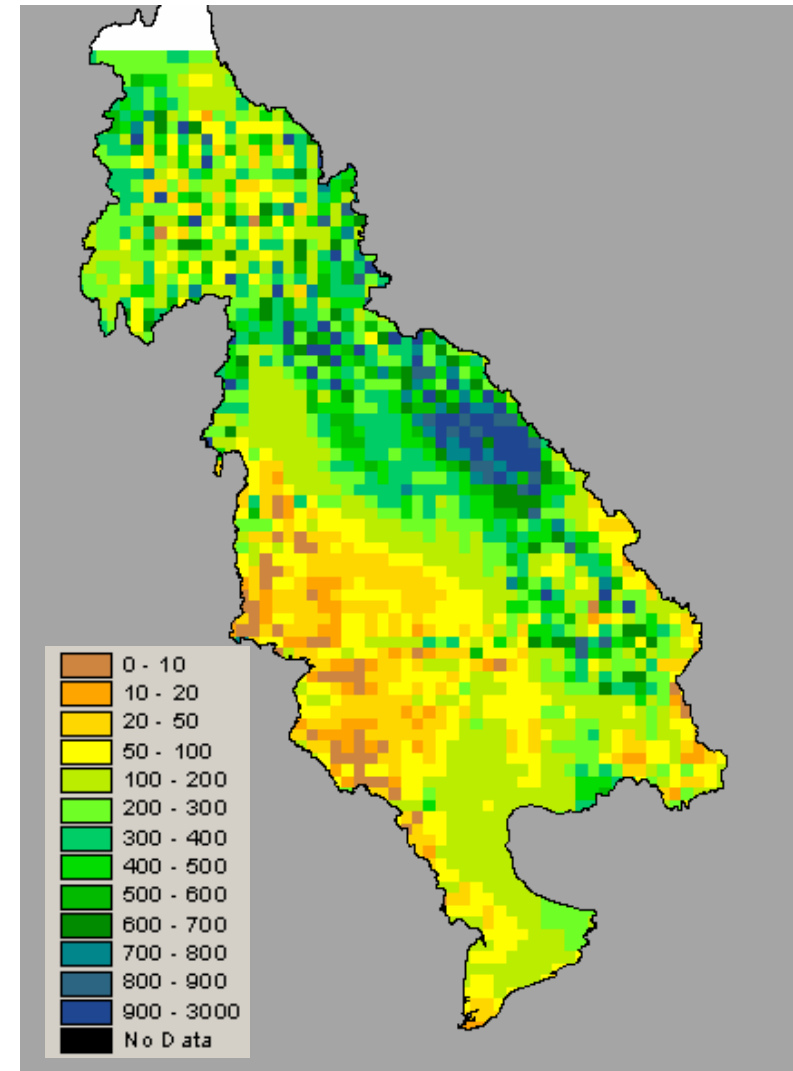

Observed and simulated monthly precipitation (mm) over the Lower Mekong River watershed in October 1994.

Interpolated surface observation

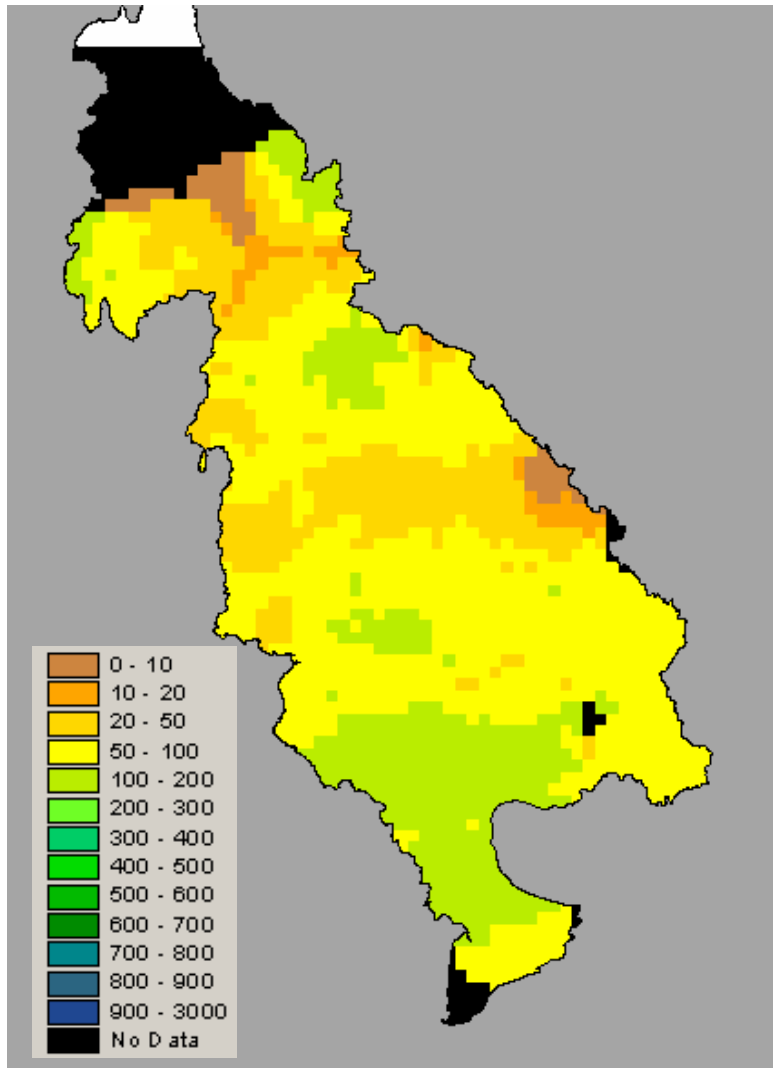

Reconstructed monthly precipitation

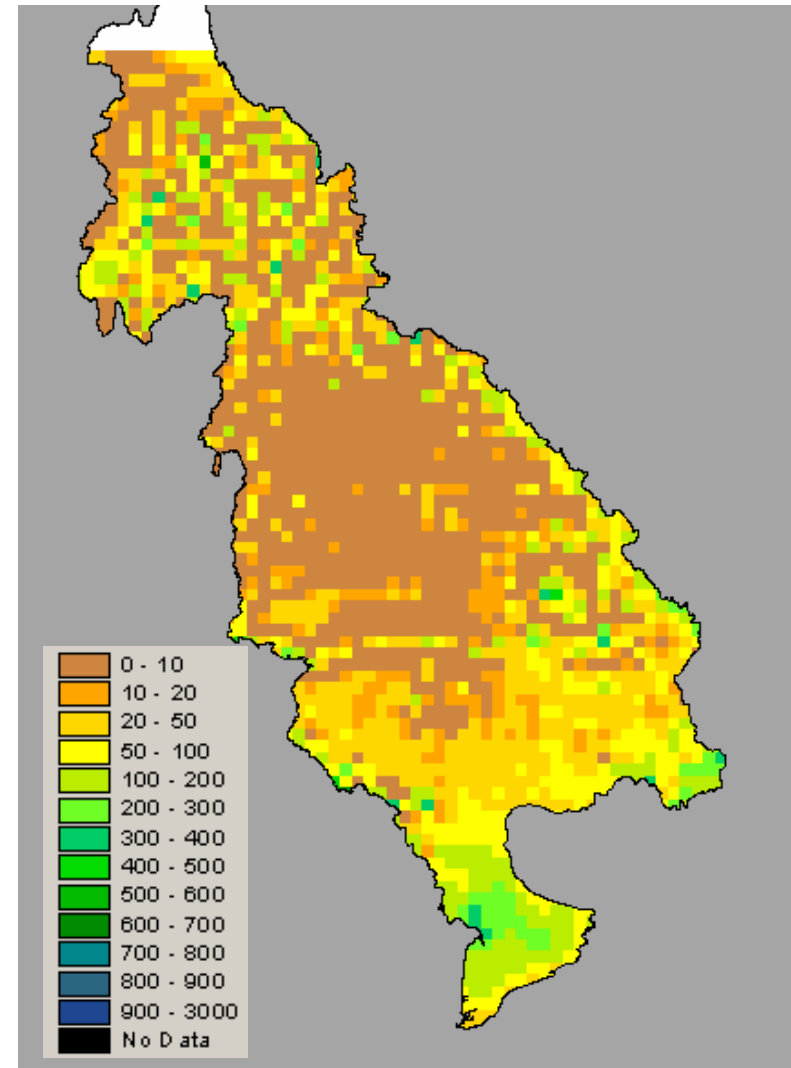

Observed and simulated monthly precipitation (mm) over the Lower Mekong River watershed in January 1996.

Interpolated surface observation

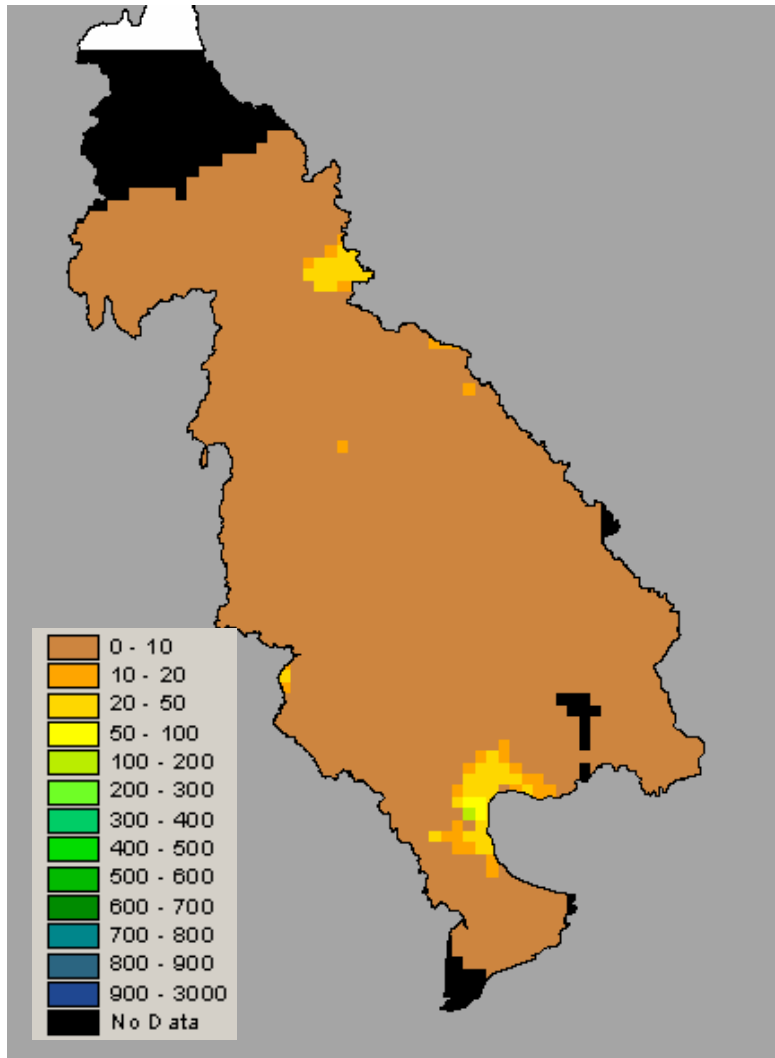

Reconstructed monthly precipitation

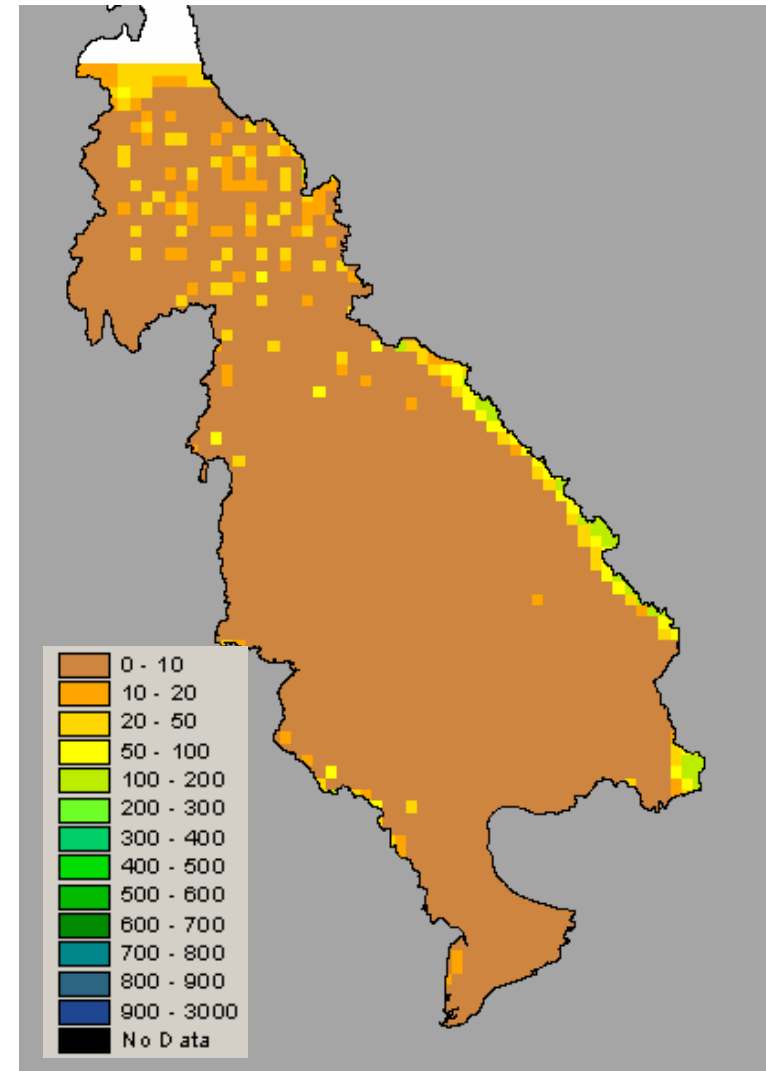

Observed and simulated monthly precipitation (mm) over the Lower Mekong River watershed in April 1996.

Interpolated surface observation

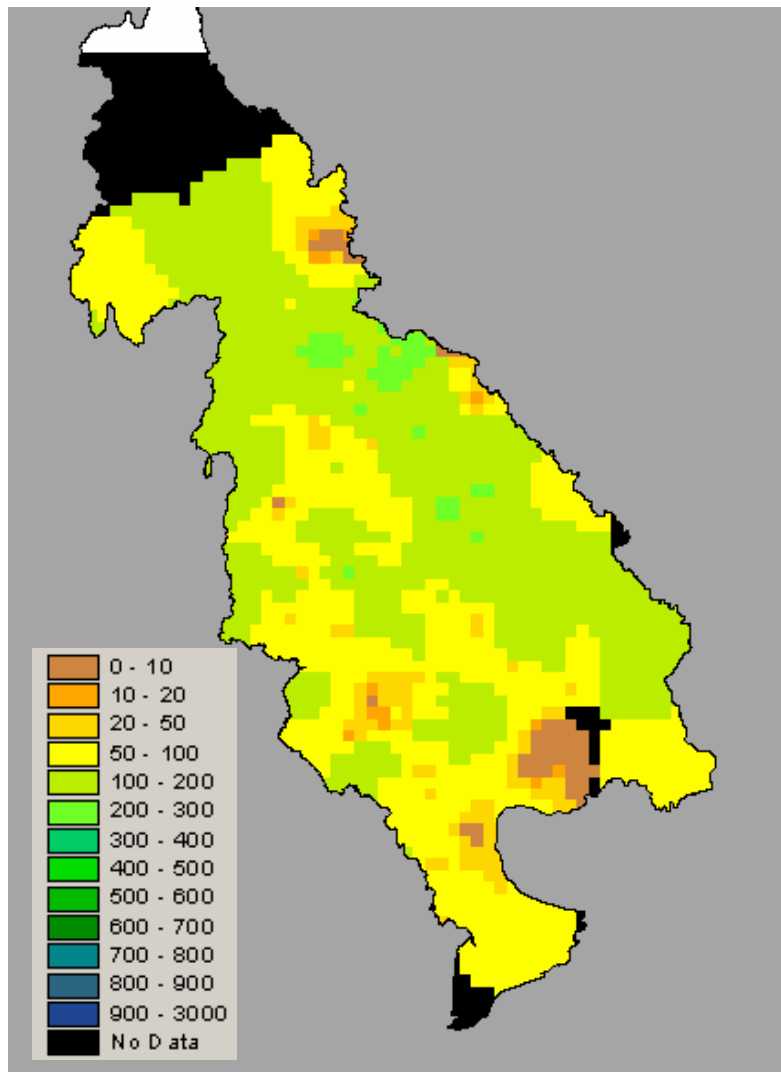

Reconstructed monthly precipitation

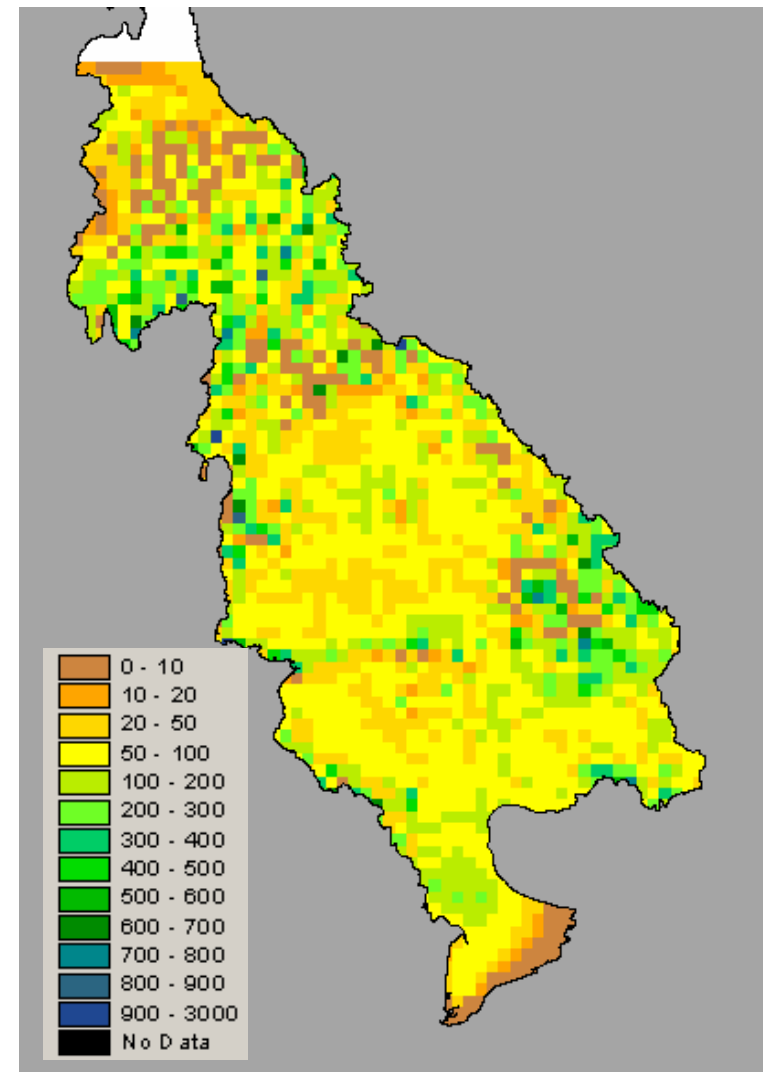

Observed and simulated monthly precipitation (mm) over the Lower Mekong River watershed in July 1996.

Interpolated surface observation

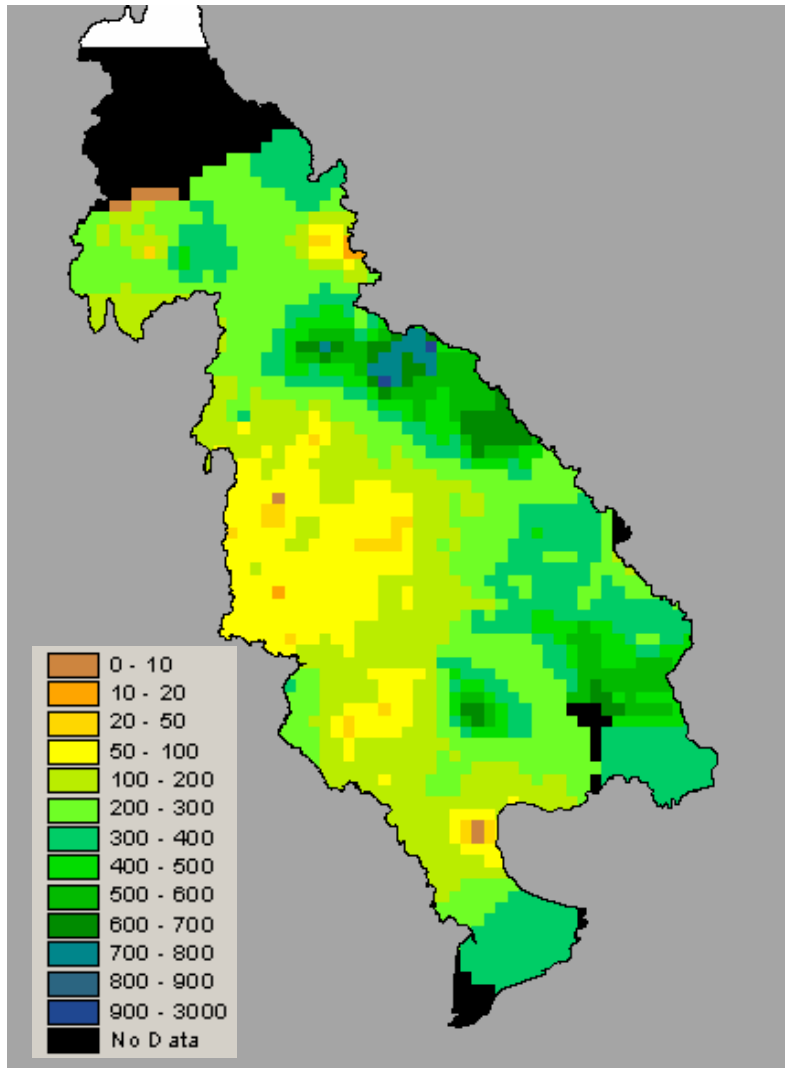

Reconstructed monthly precipitation

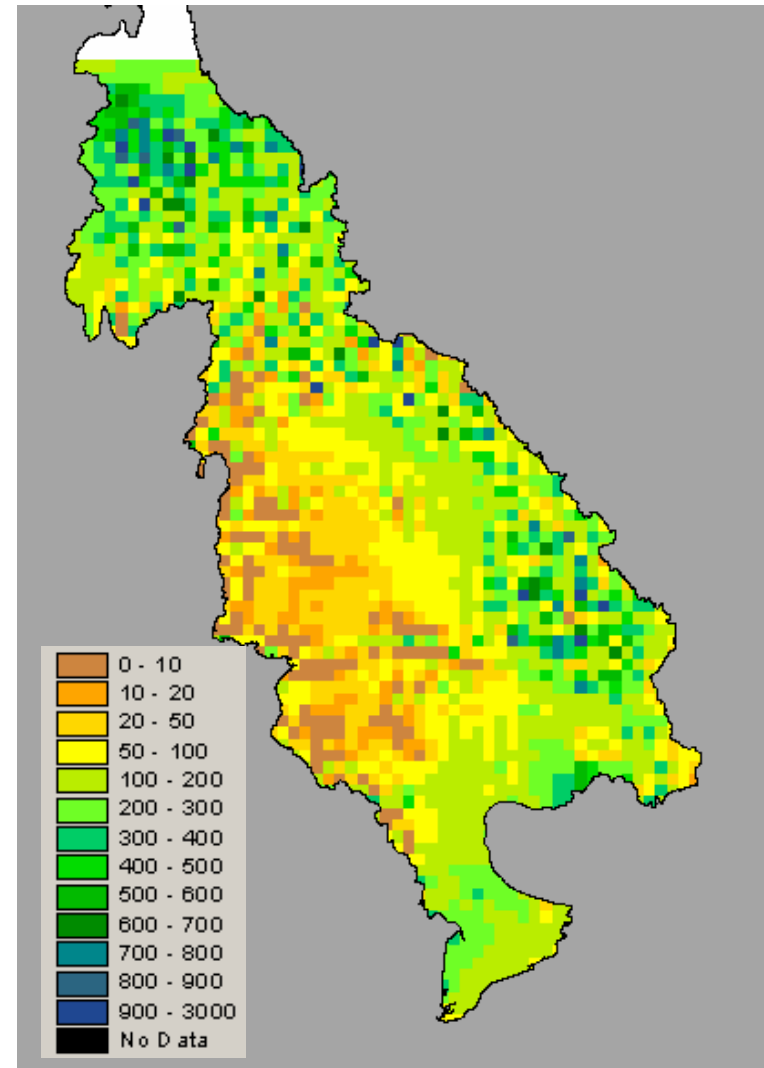

Observed and simulated monthly precipitation (mm) over the Lower Mekong River watershed in October 1996.

Interpolated surface observation

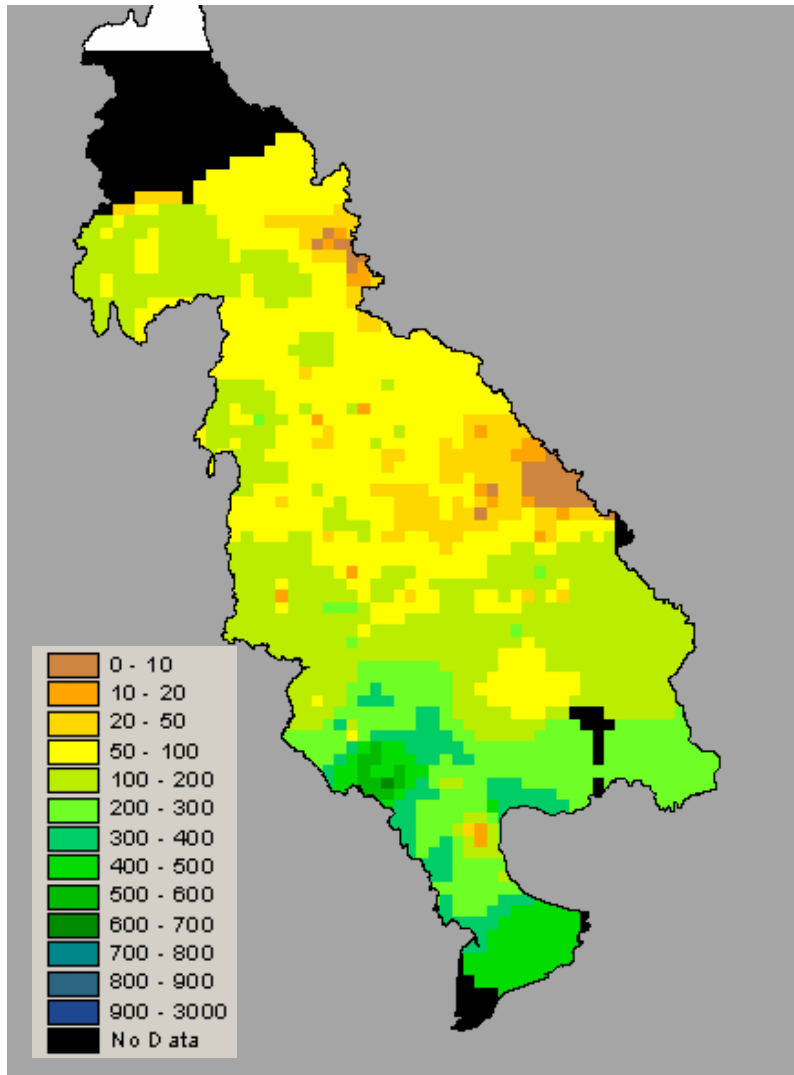

Reconstructed monthly precipitation

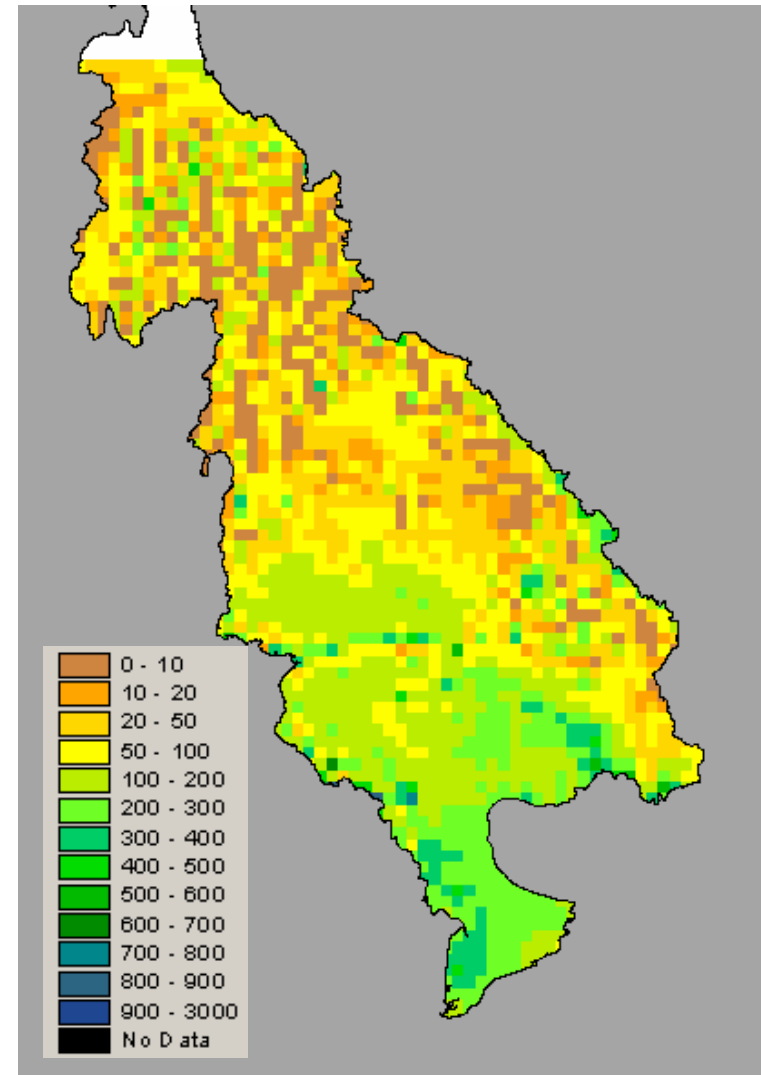

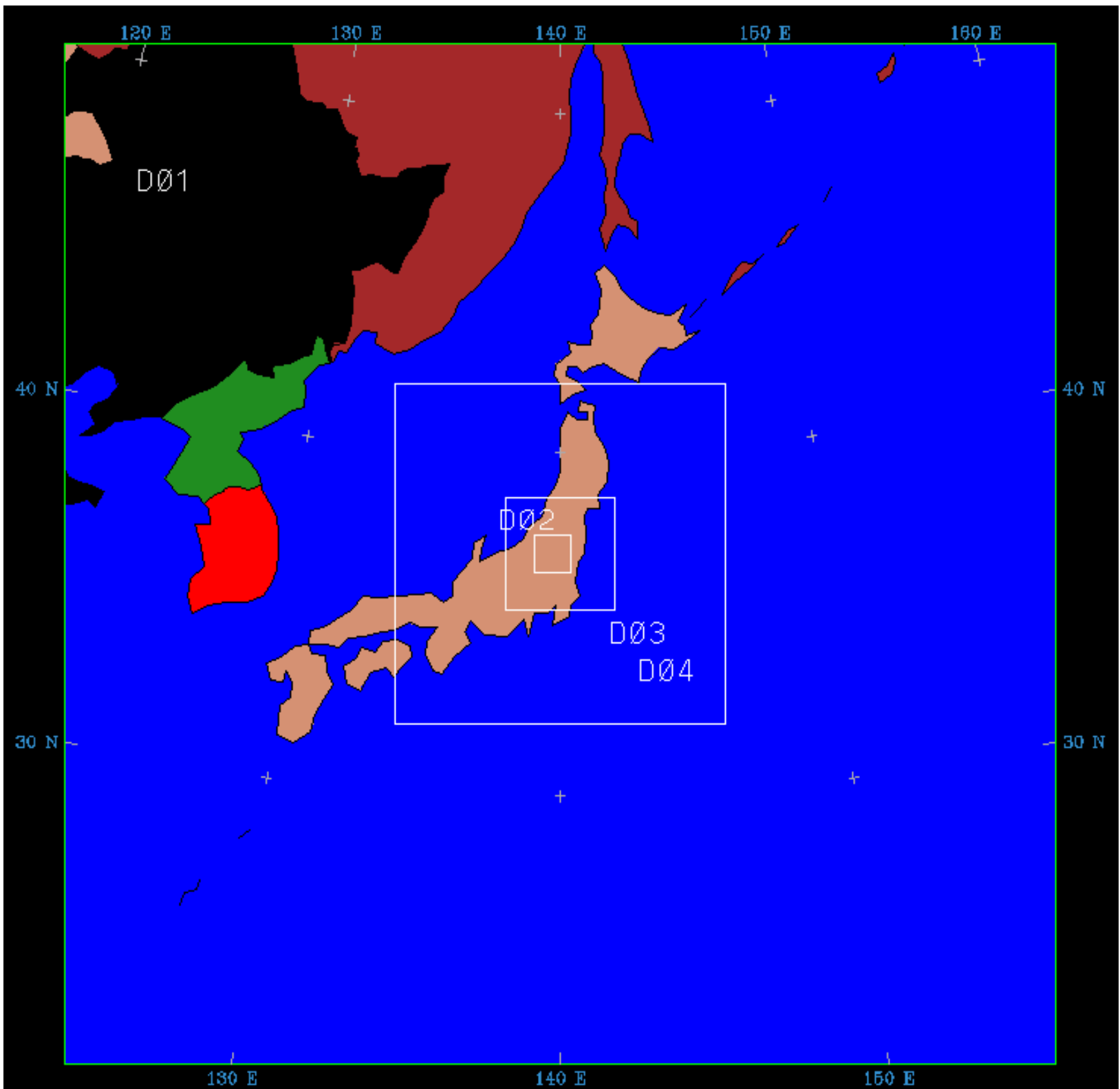

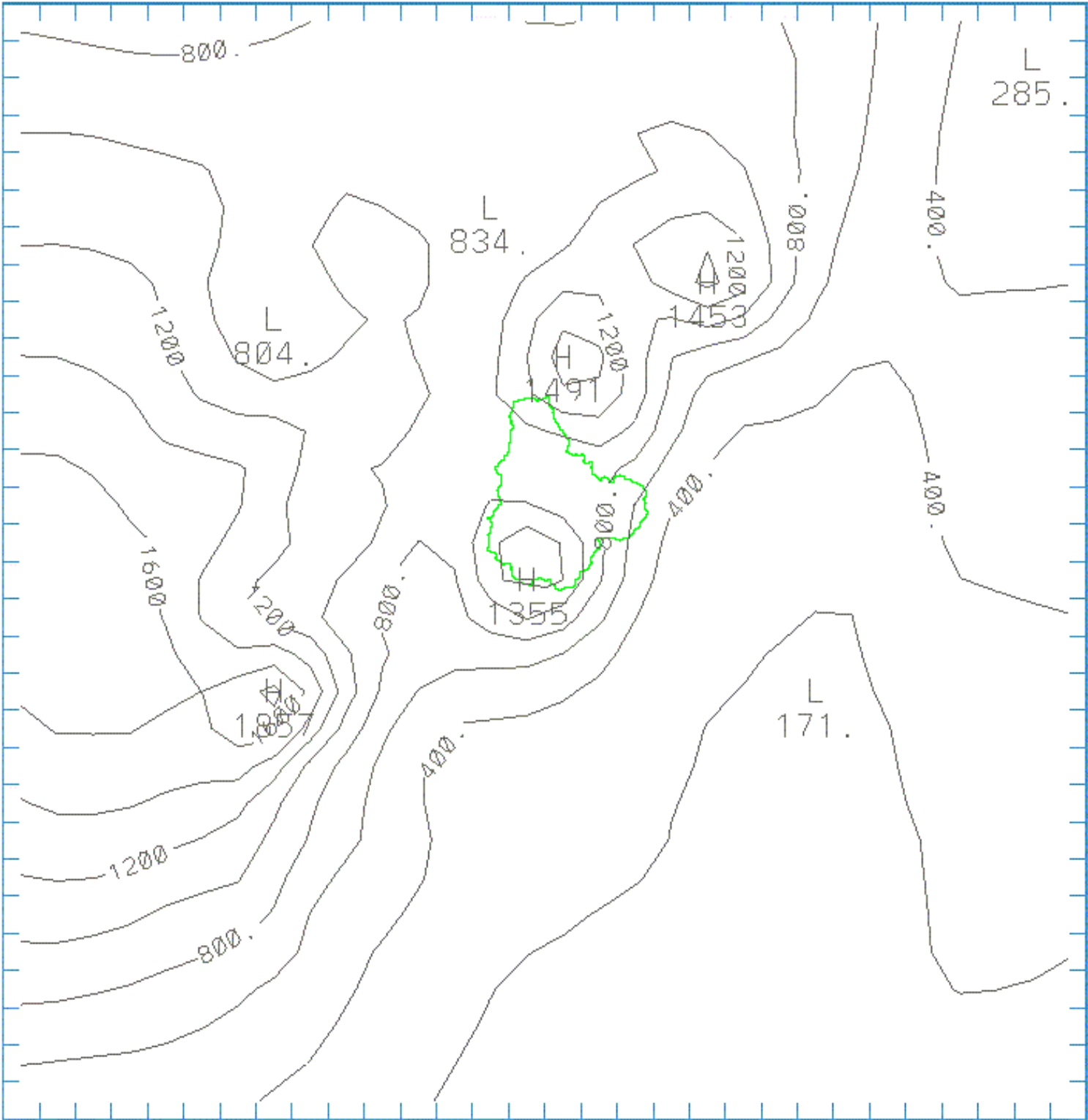

Hourly Precipitation ended at 98082713UTC (MM5 2km grid)

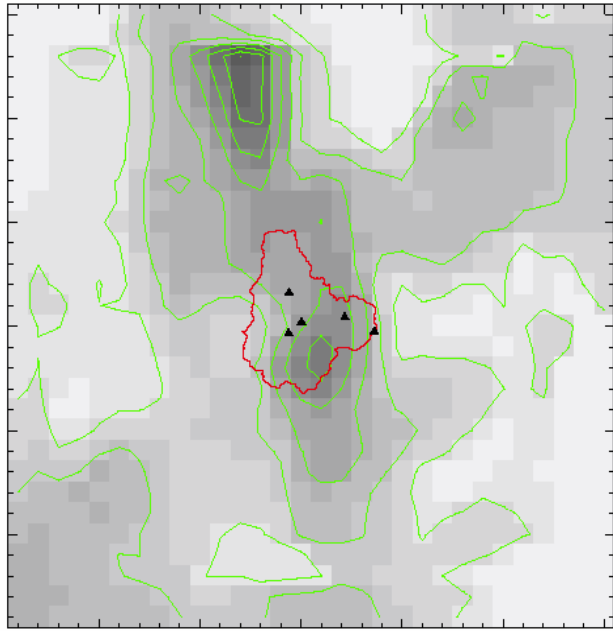

Hourly Precipitation ended at 98082714UTC (MM5 2km grid)

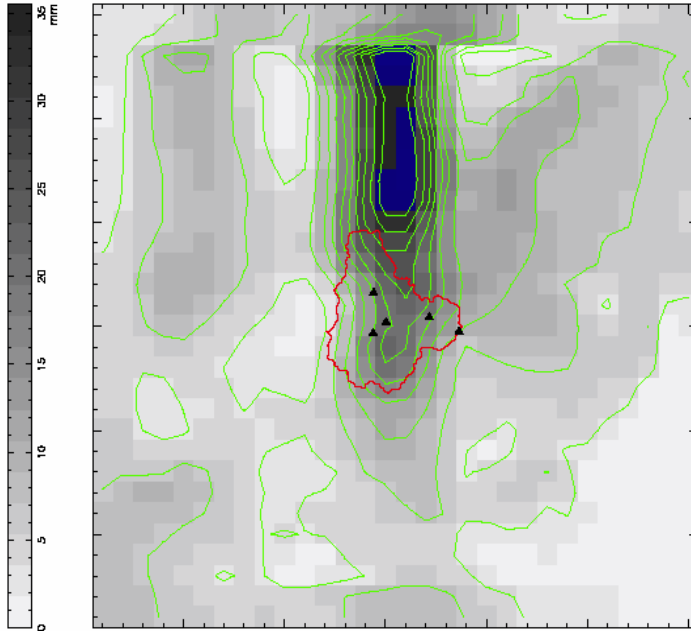

Hourly Precipitation ended at 98082715UTC (MM5 2km grid)

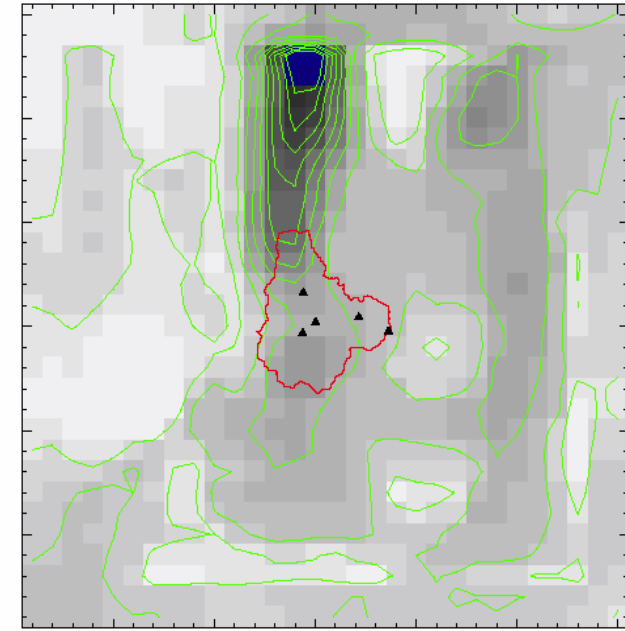

Hourly Precipitation ended at 98082716UTC (MM5 2km grid)

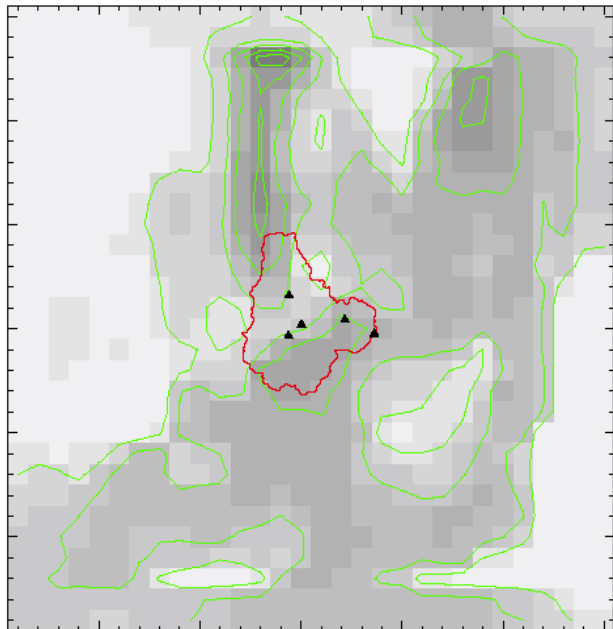

Hourly Precipitation ended at 98082717UTC (MM5 2km grid)

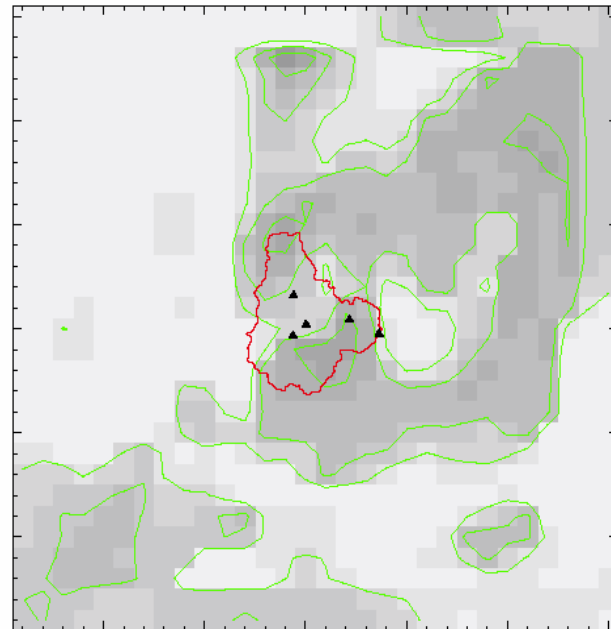

Hourly Precipitation ended at 98082718UTC (MM5 2km grid)

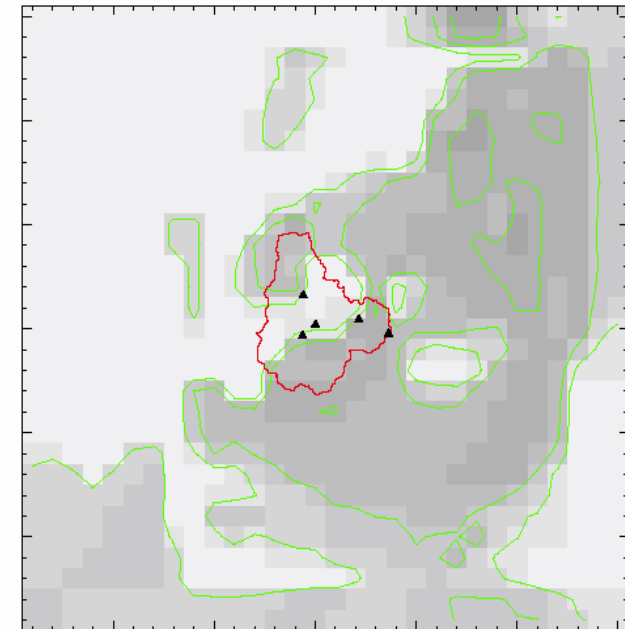

FLOOD FORECASTING BY COUPLED NUMERICAL ATMOSPHERIC AND HYDROLOGIC MODELS

**Atmospheric model MM5 with RegHCM was coupled
with WEHY model**

Precipitation forecasts of JMAM over Japan
at 20km resolution
were downscaled by MM5 to 2km resolution
as input to WEHY model

Comparison of observed runoff at the Yuunohara station versus runoff calculations based upon raingage observations and runoff forecasts based upon MM5 rainfall forecasts with WEHY model

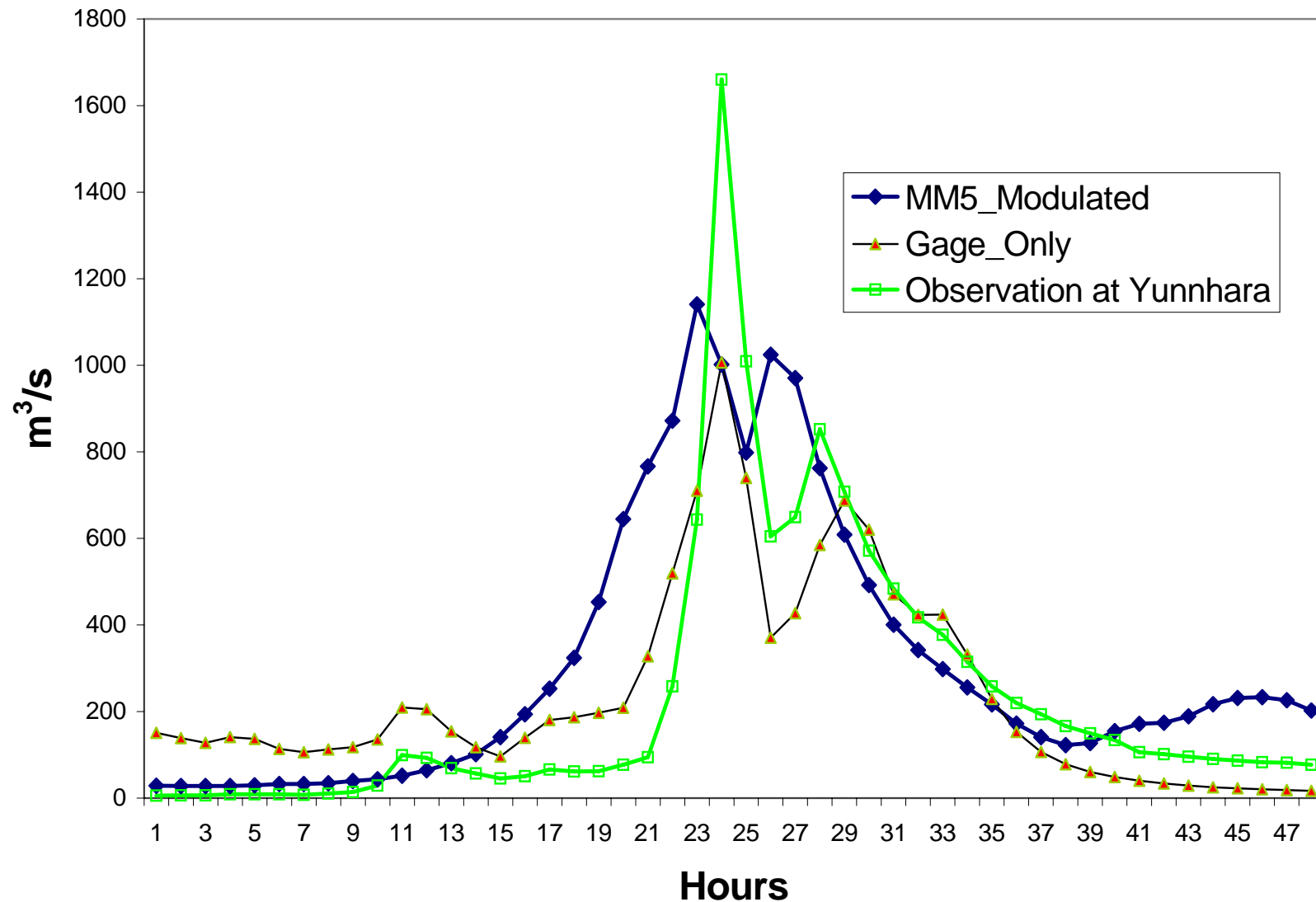

Characteristics of WEHY model

- A physically-based distributed-parameter hydrologic model
- Heterogeneity of hydrologic parameters and variables are incorporated in the basic equations, i.e. areally-averaged conservation equations
- The model parameters were estimated directly from topography, soil types, vegetation, land use/land cover data, and not from model fitting.
- Because the model incorporates explicitly the influence of land surface characteristics on the hydrologic flows and sediment/nutrient transport from a watershed, it can be used to assess quantitatively the impact of land use changes on the hydrology and environment of a watershed. Thereby, it can be utilized as an effective management tool

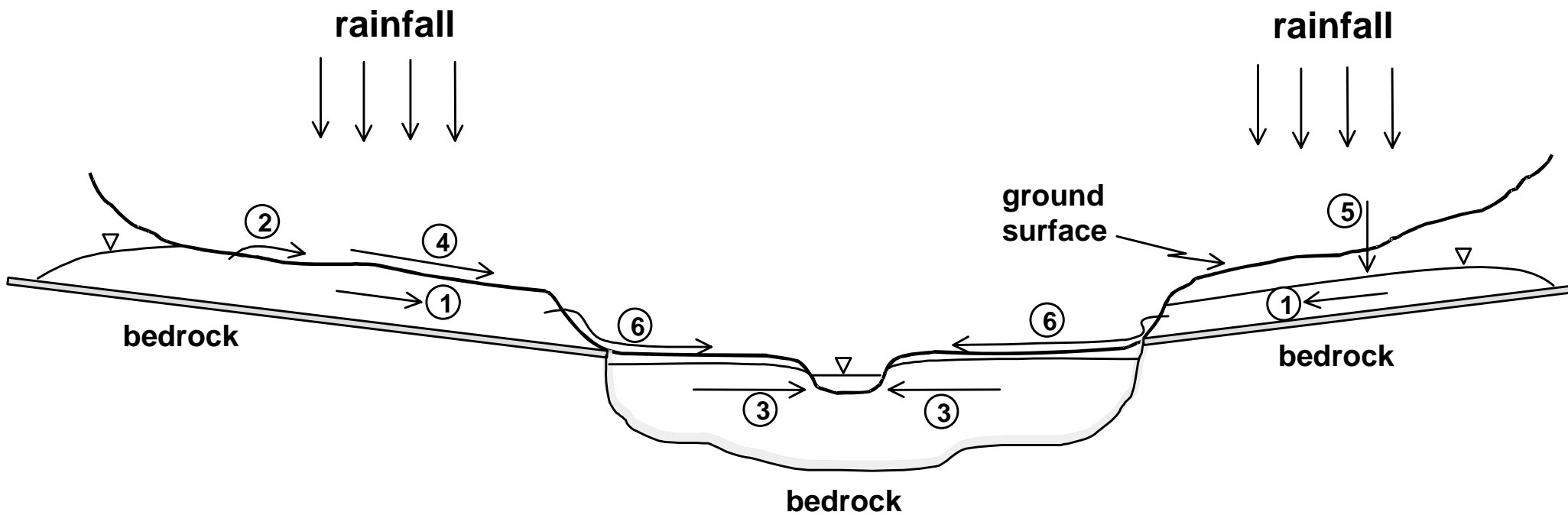

1. Subsurface stormflow,
2. Return flow,
3. Regional groundwater flow,
4. Overland flow (sheet and rill flow) caused by rainfall on variable source area,
5. Unsaturated vertical flow,
6. Seepage from subsurface stormflow.

INPUTS

Parameter values related to topography, geometry and soil characteristics

Rainfall event

Interception and evapotranspiration model + vertical unsaturated flow and infiltration model (vertical 1-Ds)

HHP11

Program for Hillslope Hydrologic Processes (Hybrid 1-Ds)

Subsurface stormflow (horizontal 1-D)

Overland flow (sheet and rill flow) (1-Ds)

Regional groundwater (2-D)

Stream network flow (1-Ds)

SNRG12

Program for Stream Network and Regional Groundwater (1-Ds and 2-D)

OUTPUT

Evapotranspiration

Runoff hydrograph

General structure of WEHY model

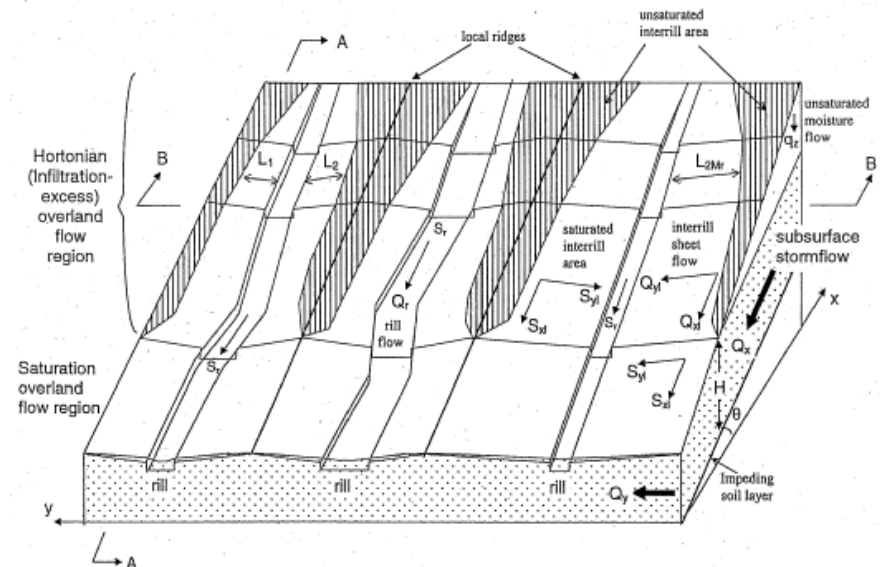
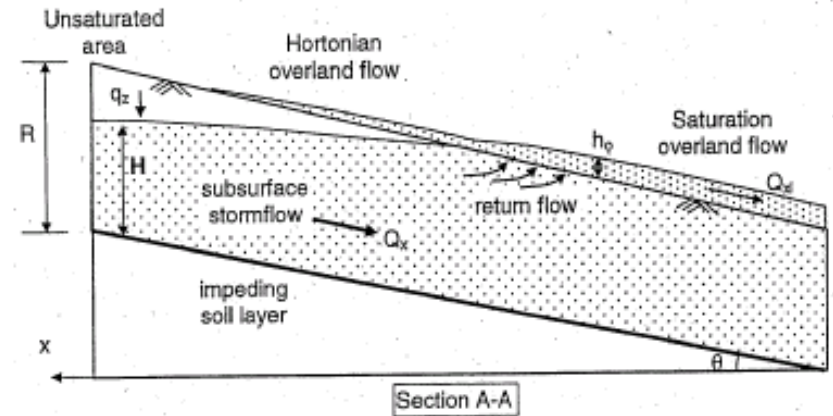

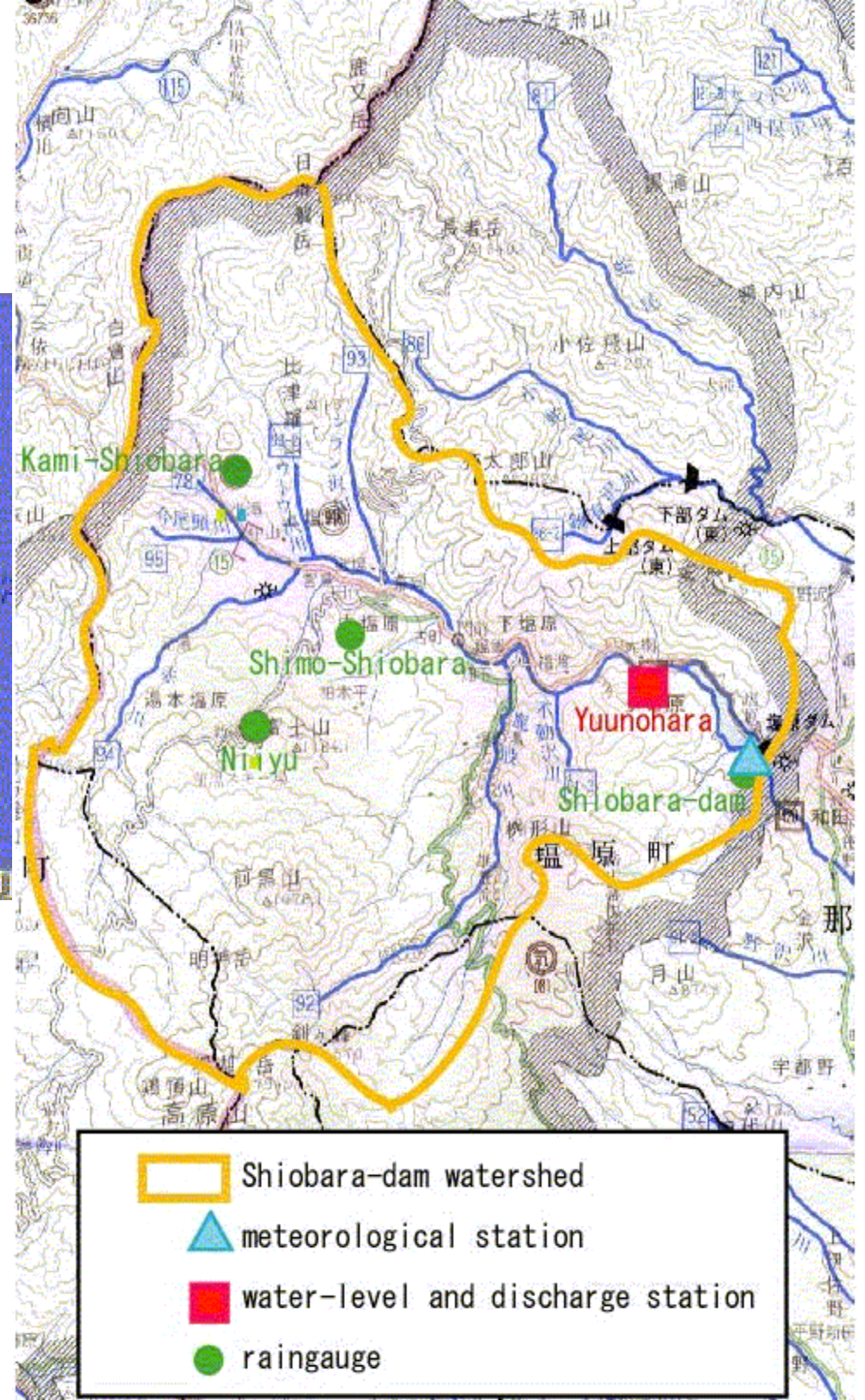
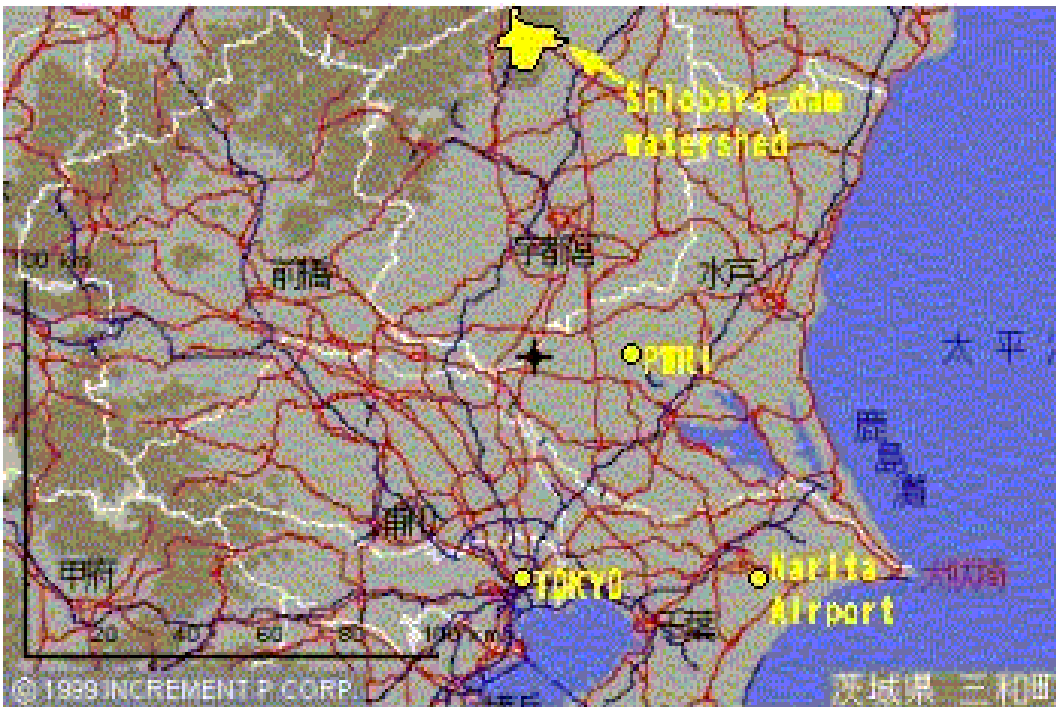

Total Drainage Area of
Shiobara Dam Basin
= 123 km²

Model computational units

Hillslope MCUs

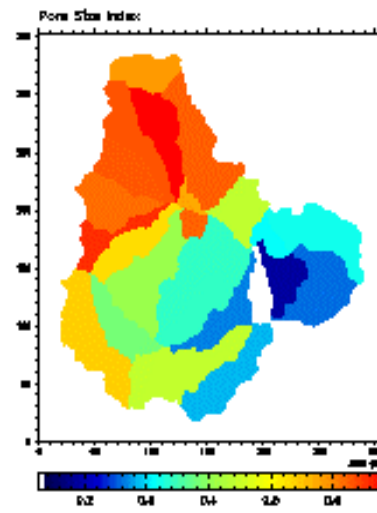
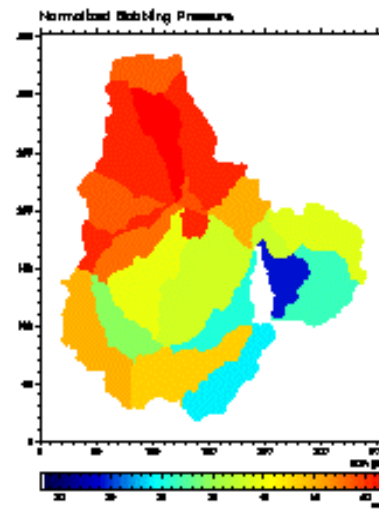
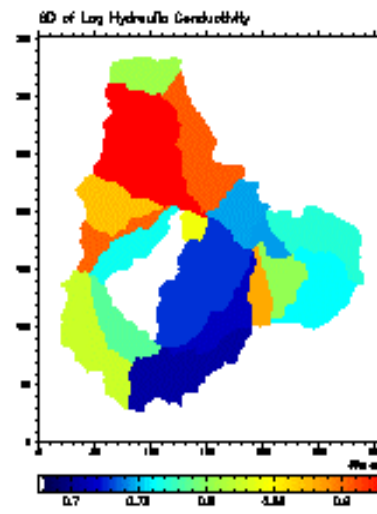
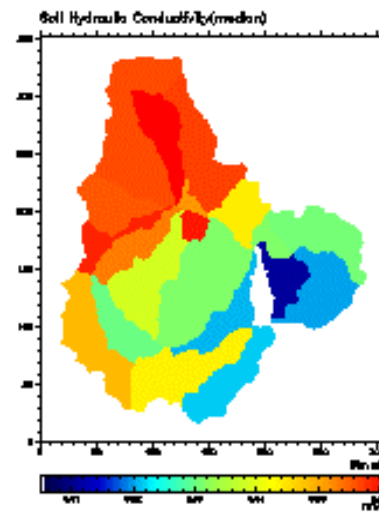
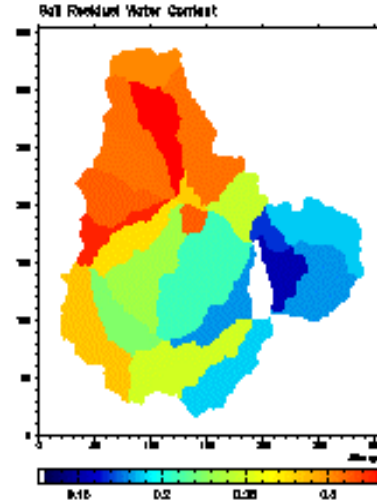
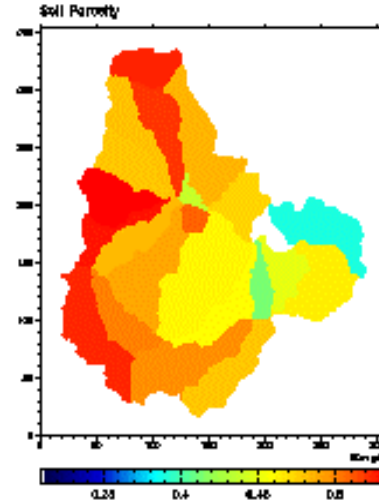
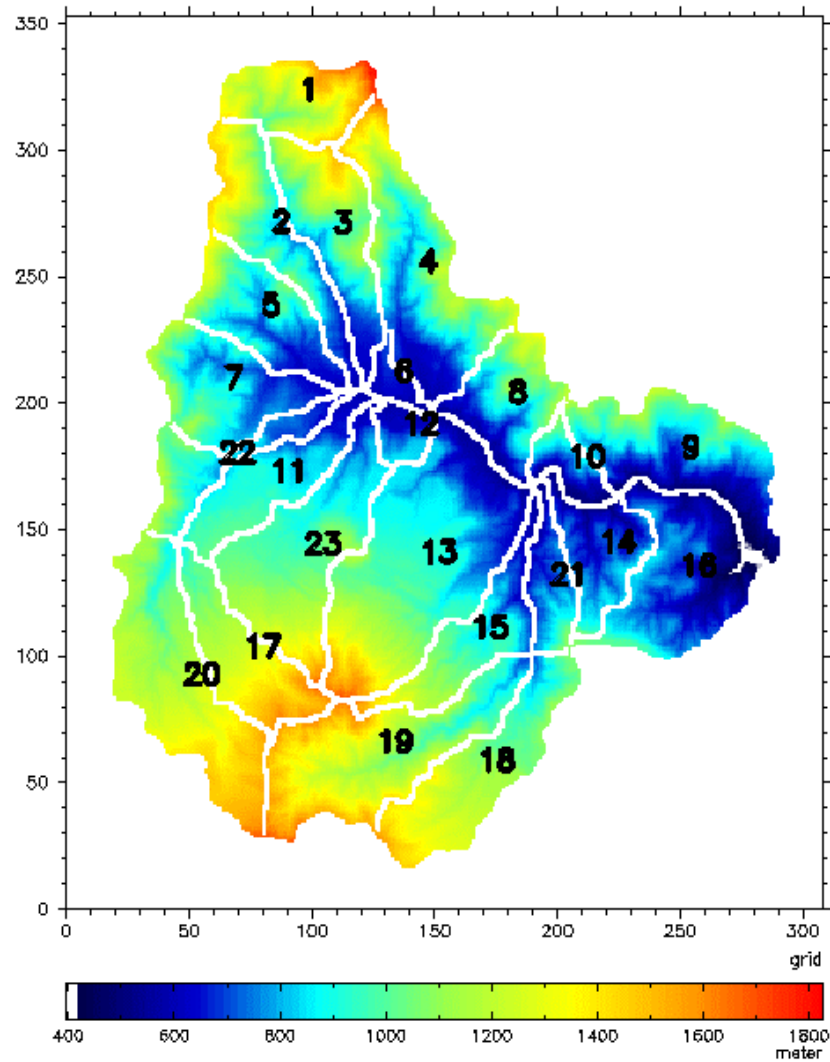

Soil
parameter
s

Estimation of Soil depth

Soil Depth

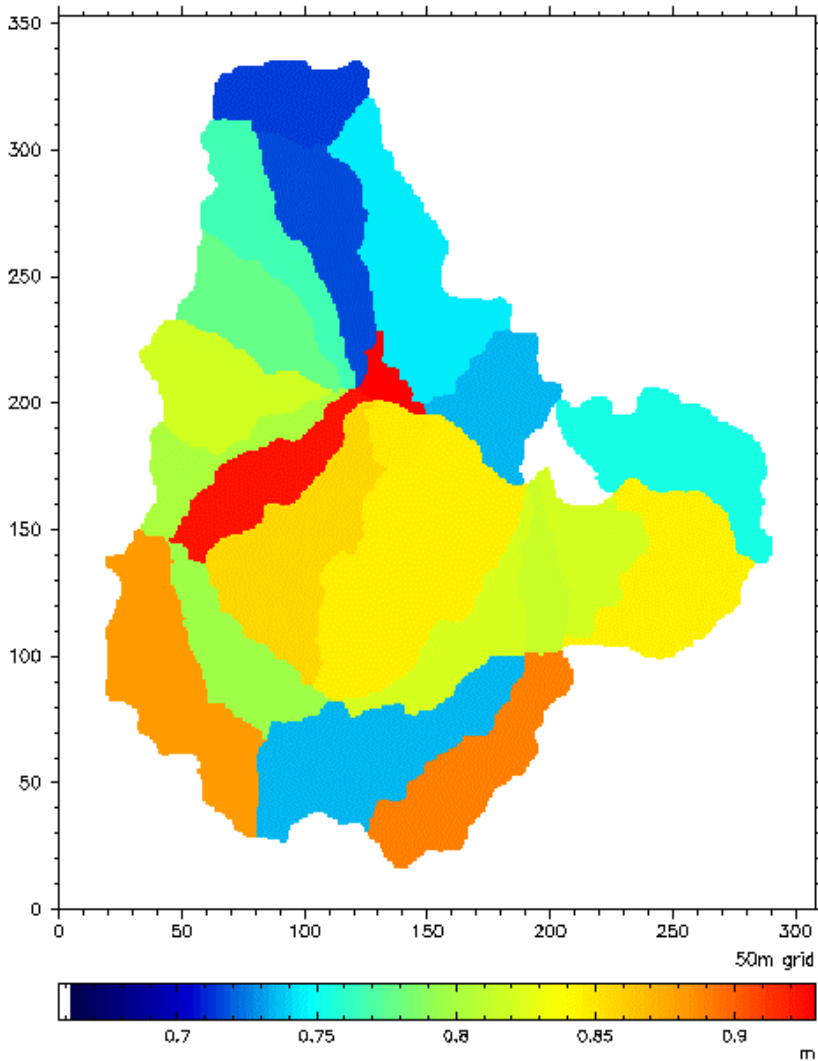

Profile section	Slope angle (degree)	Rank (point)	Conifer forest	Broad-leaf forest	Cryptomeria japonica etc.	Grass land	Field	Paddy field	Other
			+1	+2	+2	+1	+1	+2	0
Convex feature	0-8	+2	3	4	4	3	3	4	2
	8-25	+2	3	4	4	3	3	4	2
	25-	+1	2	3	3	2	2	3	1
Concave feature	0-8	+3	4	5	5	4	4	5	3
	8-25	+3	4	5	5	4	4	5	3
	25-	+2	3	4	4	3	3	4	2
Bevel	0-8	+2	3	4	4	3	3	4	2
	8-25	+1	2	3	3	2	2	3	1
	25-	0	1	2	2	1	1	2	0
Flat plane	-	+2	3	4	4	3	3	4	2

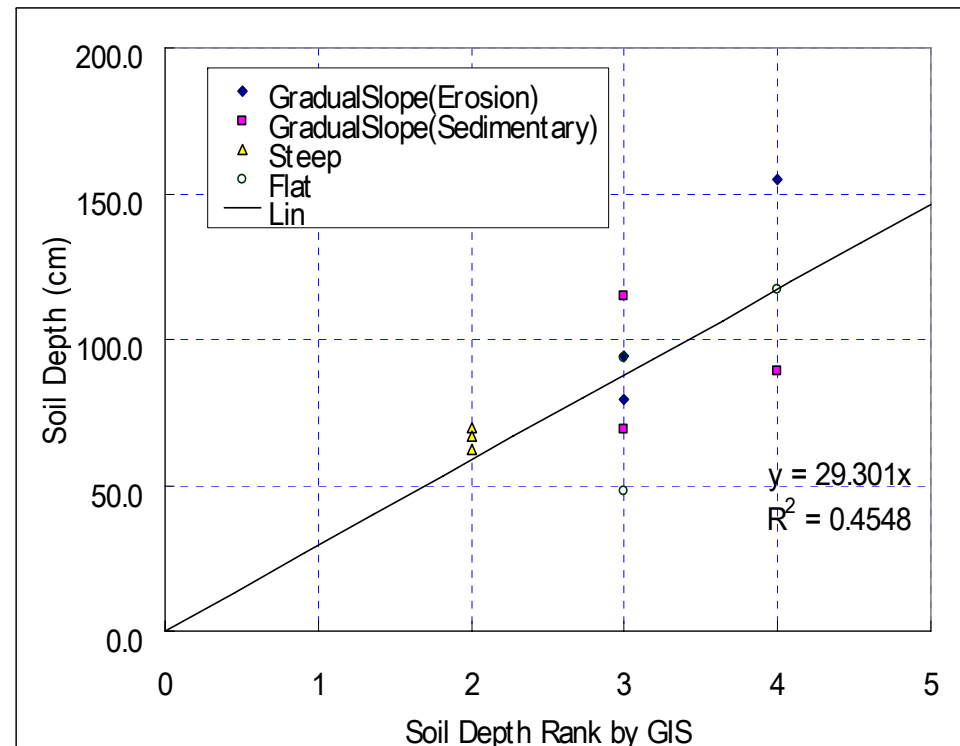

Flood runoff simulation by WEHY model

Discharge at Yuunohara

9/12/98--9/21/98

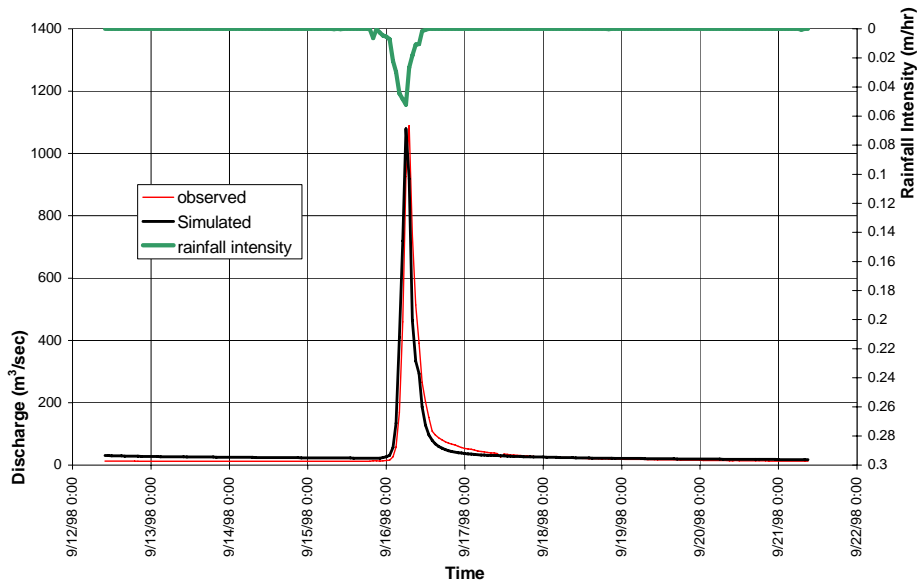

Discharge at Yuunohara

10/14/98 -- 10/21/98

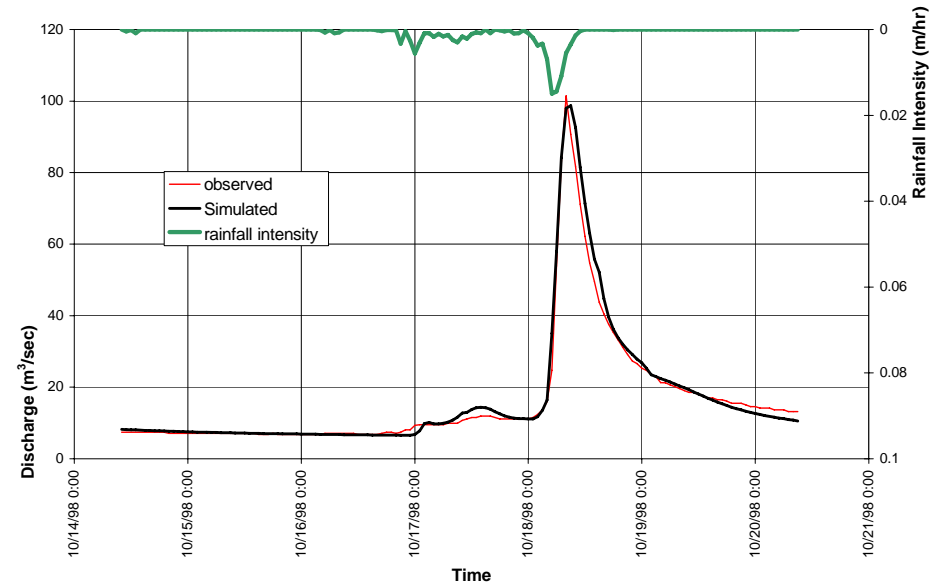

Contributions from Different Flow Processes to Discharge at Yuunohara

9/12/98--9/21/98

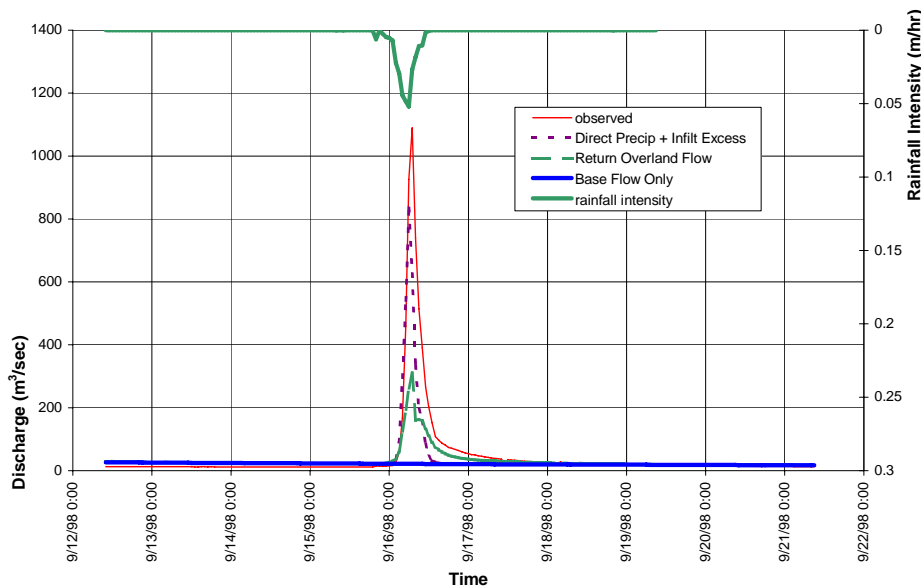

Contributions from Different Flow Processes to Discharge at Yuunohara

10/14/98 -- 10/20/98

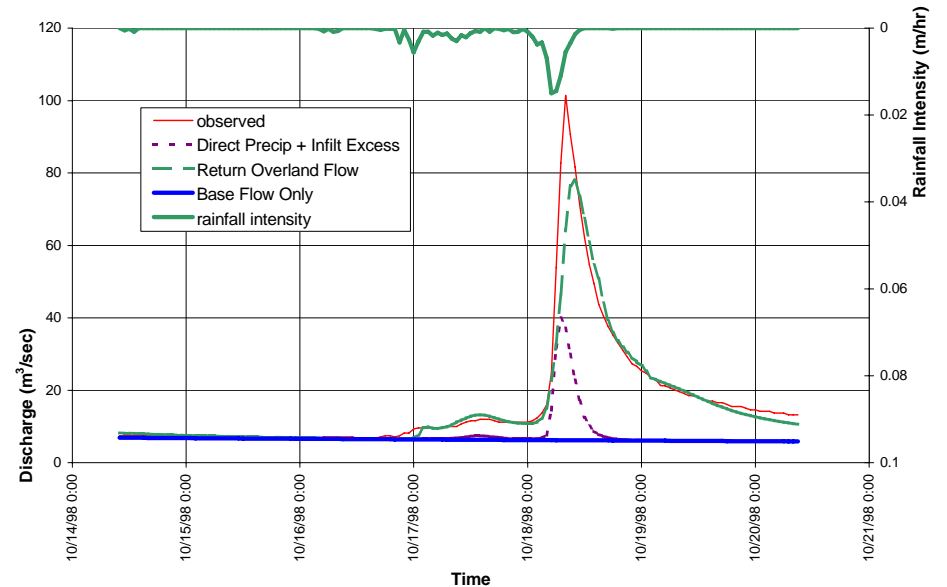

Watershed Environmental Hydrology (WEHY) Model Applications

- Not only for flood forecasting but also for.....
- Spatially distributed snow accumulation and snowmelt
- Spatially distributed Sediment Loading
- Non-point source transport of nutrients

[3]

Development of a common basis
for quick & efficient
implementations of flood
forecasting and
warning systems
even in poorly-gauged basins

Cooperative research among PWRI/ICHARM,
Infrastructure Development Institute (IDI)
& private consulting companies

A direction to overcome the technical issues for hydrologic forecasting in ungauged basins

- 1. Acquisition of real-time hydrologic information**
 - ← Satellite-derived rainfall and runoff analysis using the rainfall data
- 2. Hydrologic model parameter estimation and verification**
 - ← Application of a practical & distributed-parameter hydrologic model, which can be constructed on the basis of globally-available GIS datasets.
- 3. Identification of relative level of flood risk**
 - ← Frequency analysis of calculated flood peaks

- Development of a common basis for quick & efficient implementations of flood forecasting and warning systems even in poorly-gauged basins

=

A computer software package specifically for flood runoff analyses with GUI using satellite-based rainfall data

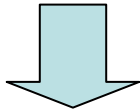

“Integrated Flood Analysis System (IFAS)”

being developed by

Joint research among PWRI/ICHARM, IDI, and nine major civil-engineering consulting companies (FY2005-2006)

Concept of IFAS

- Availability in poorly-gauged basins
 - Utilization of not only ground-based but also satellite-based rainfall data
 - A default flood runoff calculation model with globally-available GIS
- User-friendly graphical interfaces for data input, analysis & output, and light to run
- Easy & flexible maintenance and upgrade of runoff calculation models
- A default rainfall-runoff model will be prepared, but any model more suitable for each region can replace it and utilize the common interfaces.
- Minimal price for executables

PWRI Conceptual Distributed-Parameter Hydrologic Model (PDHM, Ver.2)

by Suzuki et al.(1996)

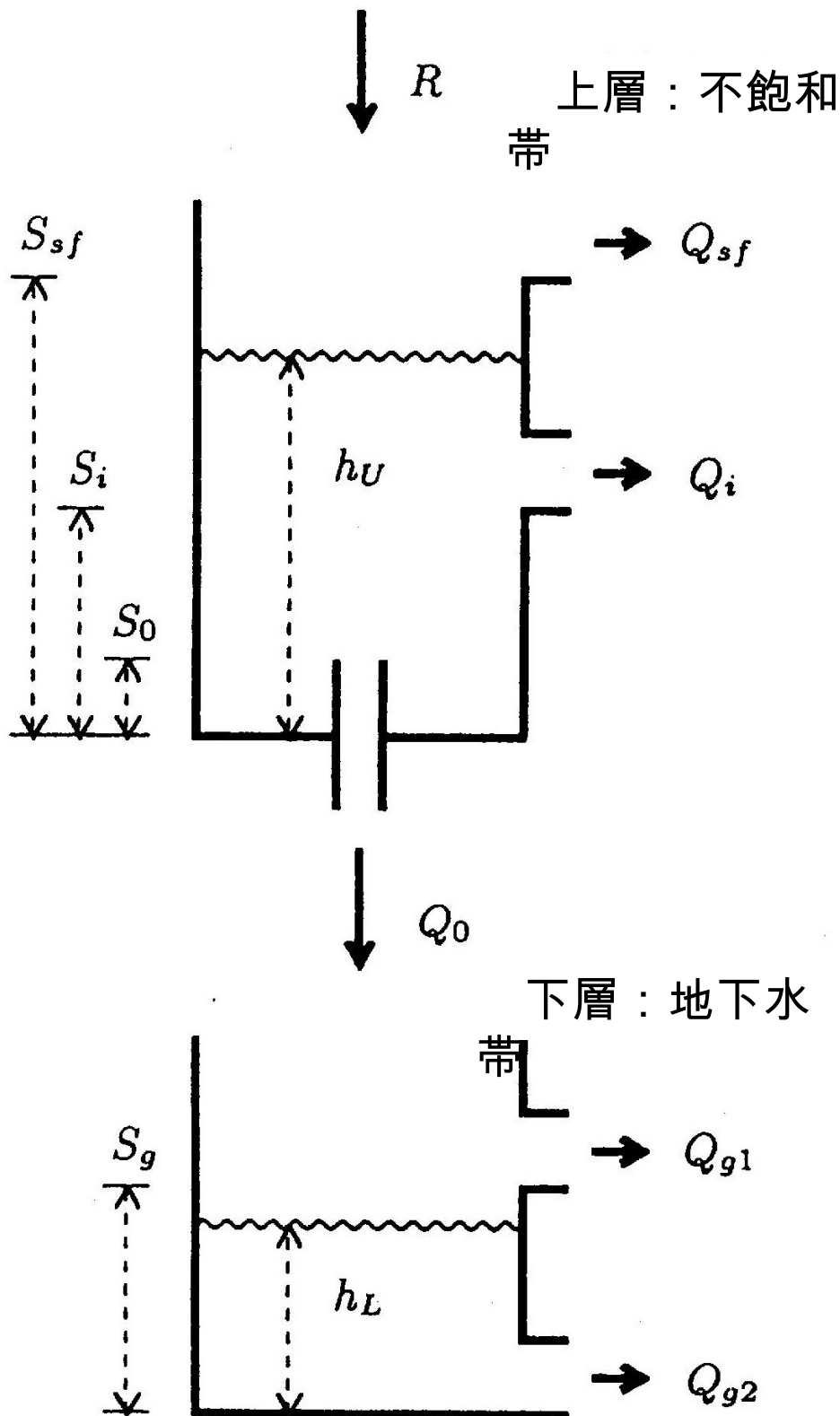

Upper layer:

Q_{sf} : surface runoff (Manning eq.)

Q_i : subsurface runoff (Darcy)

Q_0 : percolation (Darcy)

Lower layer:

Q_{g1} : Unconfined groundwater runoff

Q_{g2} : Confined groundwater runoff

River routing:

Kinematic-wave method

Global GIS for parameterization of runoff model

1. Topography: USGS-GTOPO30

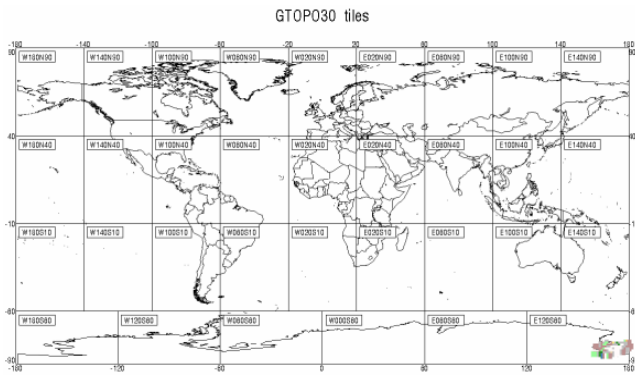

2. Land use: USGS-GLCC

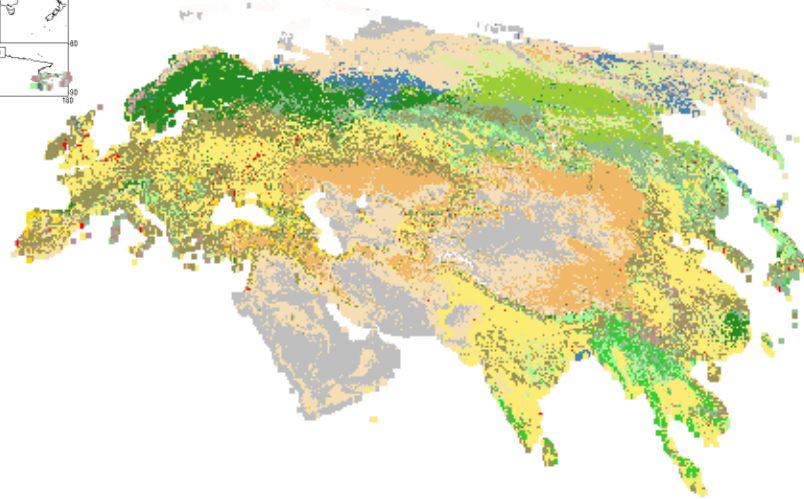

3. Soil texture: UNEP-DEWA/GRID

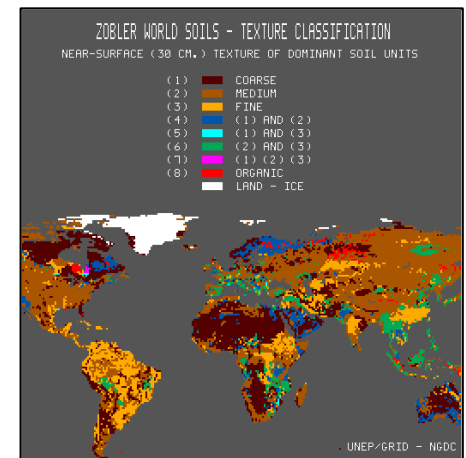

Re-test of PDHM (Ver.2)

Availability of standard parameter set and the effect of mesh size

(Shijushita Dam Watershed, Japan, $A=1,200\text{km}^2$)

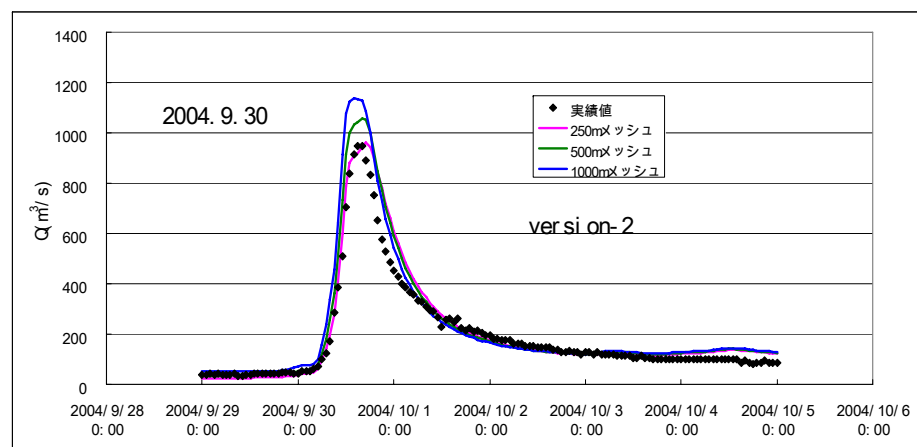
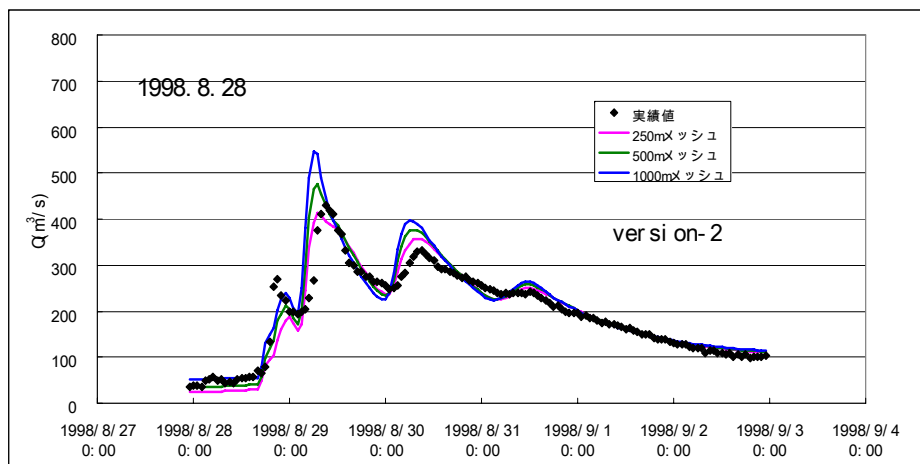
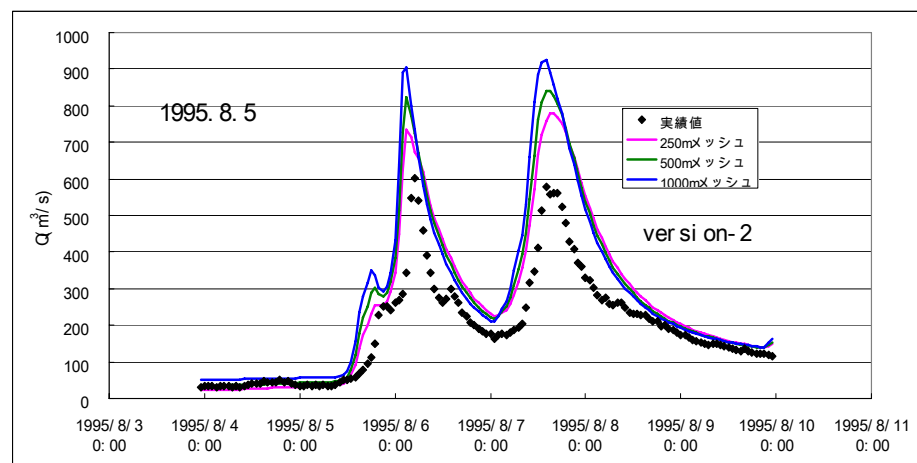
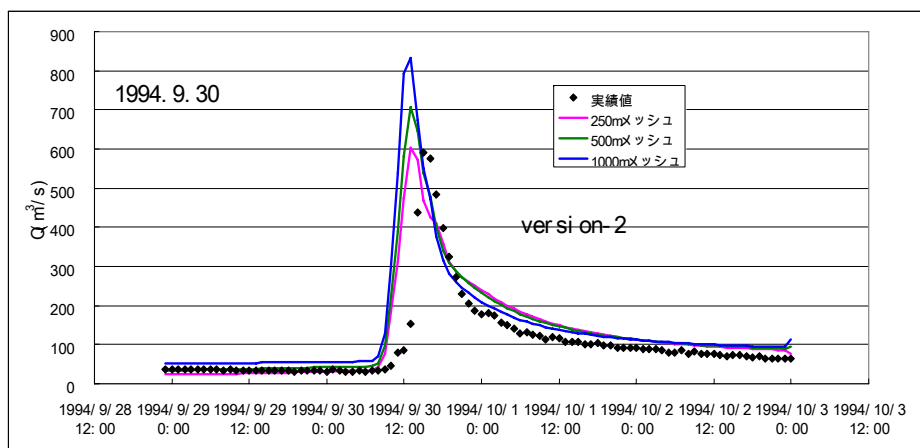

Example of tentative IFAS interface

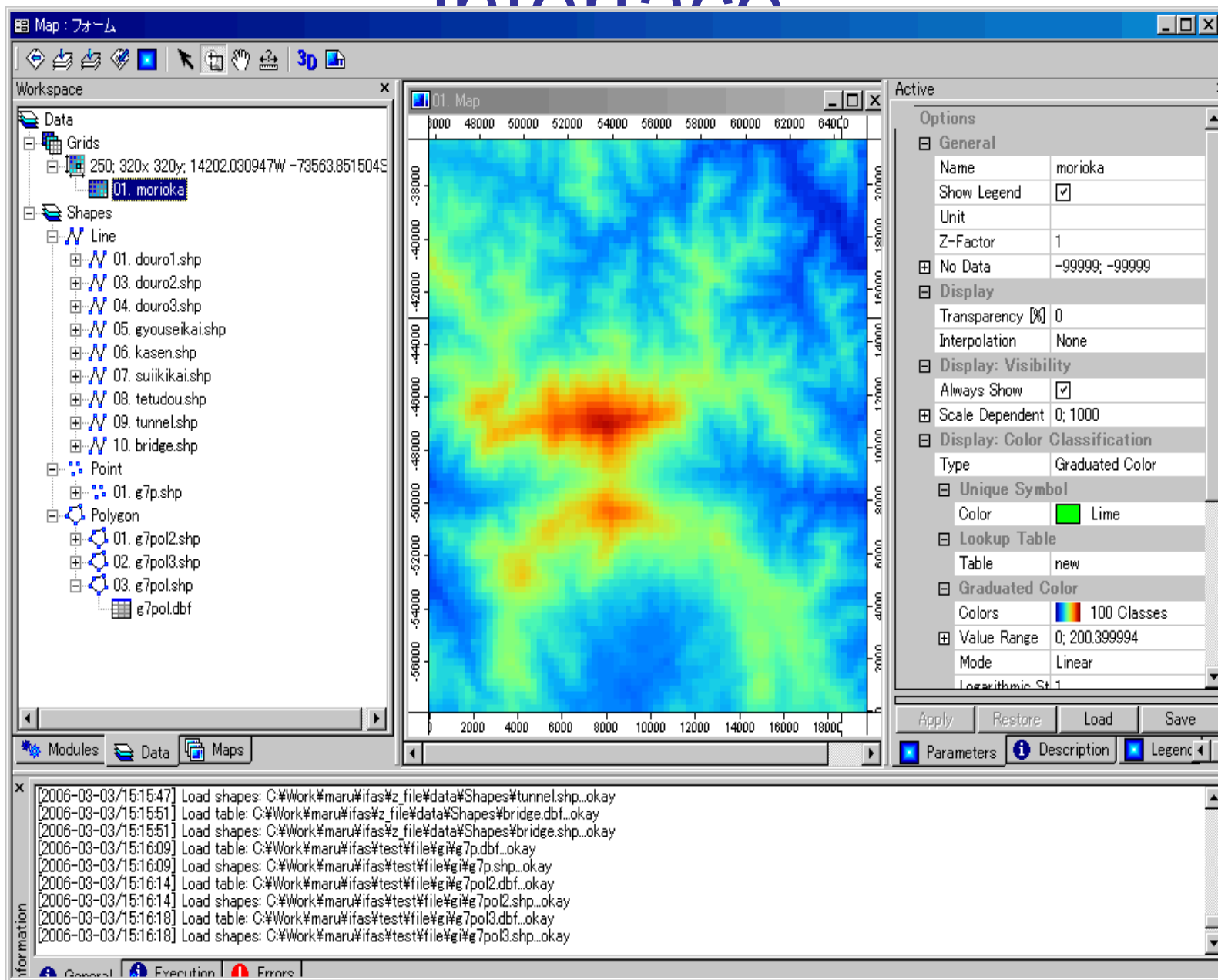

The screenshot displays the IFAS software interface with the following components:

- Map View:** A central map window titled "01. Map" showing a heatmap with a color scale from blue (low) to red (high). The x-axis ranges from 0 to 18000 and the y-axis from -56000 to -38000.
- Workspace:** A tree view on the left showing a project named "01. morioka" containing various data layers:
 - Data:** Grids (250x320x320) and "01. morioka".
 - Shapes:** A list of line shapes (01.douro1.shp to 10.bride.shp) and point shapes (01.g7p.shp).
 - Polygon:** Three polygon shapes (01.g7pol2.shp to 03.g7pol3.shp) and a database file (g7pol.dbf).
- Options Panel:** A right-hand panel for "01. morioka" with the following settings:
 - General:** Name: morioka, Show Legend: , Unit: (empty), Z-Factor: 1.
 - No Data:** -99999; -99999
 - Display:** Transparency [%]: 0, Interpolation: None.
 - Display: Visibility:** Always Show: , Scale Dependent: 0; 1000.
 - Display: Color Classification:** Type: Graduated Color.
 - Unique Symbol:** Color: Lime.
 - Lookup Table:** Table: new.
 - Graduated Color:** Colors: 100 Classes, Value Range: 0; 200.399994, Mode: Linear.
- Log Window:** A bottom window showing a series of log messages from 2006-03-03, detailing the loading of various shapefiles and tables.

Examples of IFAS applications

- Utilization as a common toolkit for quick and efficient implementations of flood forecasting and warning systems in developing countries
- Utilization as a toolkit for flood control planning and management in poorly-gauged river watersheds
- Utilization as a common toolkit for training courses on flood runoff modeling and forecasting at ICHARM, etc.
- Utilization as a base for upgrading IFNet-GFAS, “next-phase GFAS = GFAS2”, to disseminate not only extreme storm alarm but also extreme flood alarm

Current research activities and future subjects at PWRI/ICHARM in relation to flood forecasting

1. Development of satellite-based global real-time rainfall map for flood forecasting and warning on a river basin scale (with JAXA and CREST/GSMaP group)
2. Development of rainfall forecasting system for ungauged basins (with UCD)
3. Development of a common basis for quick & efficient implementations of flood forecasting and warning systems even in poorly-gauged basins (with private sectors)
4. Development of a guideline for flood warning dissemination to meet local flood-plain needs in different natural/social/monitoring
5. Development of a guideline for integrated flood management combined with other structural & non-structural measures

Thank you very much
for your attention!

