

TABLE OF CONTENTS	Page
1. OVERVIEW OF WORKSHOP AND BUDGETS RESULTS	1
2. BUDGETS FOR AUSTRALIAN ESTUARINE SYSTEMS	9
2.1 Queensland and New South Wales Tropical and Sub-tropical Systems	9
2.1.1 Tropical systems (Jardine, Annan, Daintree, Moresby)	9
- Brad Eyre, Peter Pepperell and Peter Davies	
2.1.2 Sub-tropical systems (Caboolture, Brisbane, Logan, Tweed, Brunswick, Richmond, Clarence, Bellinger, Nambucca, Macleay, Hastings, Manning)	12
- Brad Eyre and Peter Pepperell	
2.2 Hawkesbury-Nepean River, New South Wales	18
- G.P. Bickford and S.V. Smith	
2.3 Lake Illawarra, New South Wales	29
- Cathee Miller and John Morrison	
2.4 Gippsland Lakes, Victoria	39
- Ian T. Webster and Phillip W. Ford	
2.5 Port Phillip Bay, Victoria	48
- John Parslow	
2.6 Derwent River, Tasmania	55
- John Parslow	
2.7 Cockburn Sound, Western Australia	68
- A.W. Chiffings	
2.8 Swan Canning Estuary, Western Australia	74
- Linda Kalnejais, Kathryn McMahon and Malcolm Robb	
3. BUDGETS FOR NEW ZEALAND ESTUARINE SYSTEMS	91
3.1 Hauraki Gulf, North Island	91
- John Zeldis and S.V. Smith	
3.2 Manukau Harbour, North Island	98
- V. Dupra	
4. BUDGETS FOR PAPUA NEW GUINEA ESTUARINE SYSTEMS	103
4.1 Fly River	103
- B.N. Opdyke, A. Suzuki, Peter Davies and G. Brunskill	
5. REFERENCES	107

APPENDICES		112
Appendix I	The response of Australasian estuaries and coastal embayments to increased nutrient loadings and changes in hydrology - G. Harris	112
Appendix II	Australasian coastal systems overview - B.N. Opdyke, S.V. Smith, B. Eyre, D.T. Heggie, G.G. Skyring, C.J. Crossland and J. Zeldis	125
Appendix 111	Implications of spatial and temporal variation for LOICZ biogeochemical budgets - I.T. Webster, J.S. Parslow and S.V. Smith	129
Appendix IV	Budgets estimates by non-LOICZ approaches	145
	A) Richmond River estuary (New South Wales): inter-annual budgets from seasonal and event monitoring; a modified LOICZ approach - L.McKee	145
	B) Swan Canning estuary: seasonal nutrient fluxes using a steady-state mass balance model - D. Fredericks, D. Heggie and A. Longmore	155
Appendix V	Workshop Report	169
Appendix VI	List of Participants and Contributors	173
Appendix VII	Workshop Agenda	179
Appendix VIII	Terms of Reference for Workshop	180
Appendix IX	Glossary of Abbreviations	182

1. OVERVIEW OF WORKSHOP AND BUDGETS RESULTS

Key objectives of the Land-Ocean Interactions in the Coastal Zone (LOICZ core project of the International Biosphere-Geosphere Programme (IGBP) are to:

- gain a better understanding of the global cycles of the key nutrient elements carbon (C), nitrogen (N) and phosphorus (P);
- understand how the coastal zone affects material fluxes through biogeochemical processes; and
- characterise the relationship of these fluxes to environmental change, including human intervention (Pernetta and Milliman 1995).

To achieve these objectives, the LOICZ programme of activities has two major thrusts. The first is the development of horizontal and, to a lesser extent, vertical material flux models and their dynamics from continental basins through regional seas to continental oceanic margins, based on our understanding of biogeochemical processes and data for coastal ecosystems and habitats, and the human dimension. The second is the scaling of the material flux models to evaluate coastal changes at spatial scales to global levels and, eventually, across temporal scales.

It is recognised that there is a large amount of existing and recorded data and work in progress around the world on coastal habitats at a variety of scales. LOICZ is developing the scientific networks to integrate the expertise and information at these levels in order to deliver science knowledge that addresses our regional and global goals.

The Workshop on Australasian Estuarine Systems: Carbon, Nitrogen and Phosphorus Fluxes provided an important piece in the matrix of regional assessments being carried out by LOICZ. The Australasian region has in excess of 50 000 km of coastline (about 8% of the global coastline) and more than 750 estuaries and embayments, spanning about 35 degrees of latitude from the tropics to sub-temperate areas. In addition to the climatic gradient, there is a diversity of river flows (controlled and uncontrolled), human pressures and modifications in the drainage basins and coastal fringe, and a diversity of estuarine morphologies. This extensive coastal margin with its broad latitudinal range and diverse human influences backed by a recent history of sustained coastal science enterprise (hence, a rich database) provided an opportunity to:

- a) evaluate comparatively regional biogeochemical budgets in the region; and
- b) gain a picture of changes and variability in coastal biogeochemical processes in response to both natural and anthropogenic forcing functions.

The Workshop was held at the Commonwealth Scientific and Industrial Research Organisation (CSIRO) Land & Water laboratories in Canberra, Australia, on 12-14 October 1998. The objectives of the Workshop (Appendix VIII) and the activities (Appendix V) are provided in this report. Two resource persons (Prof Steve Smith and Dr Chris Crossland) worked with 19 scientists from a number of Australasian coastal

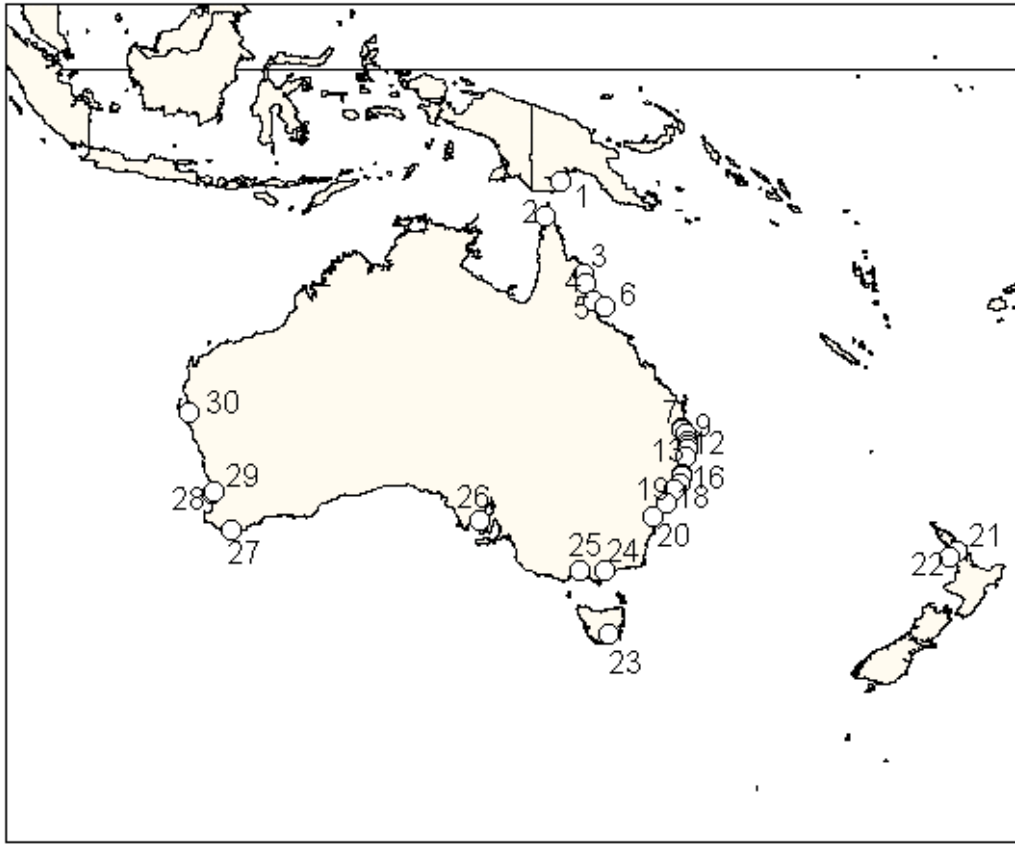

Figure 1.1 Location of LOICZ Australasian sites used for biogeochemical budgeting. (The numbered circles identify site locations identified in Tables 1.1-1.3 and in the text. Note: because of space, not all of the circles are individually numbered. However, the numbering sequence is clear.)

science agencies and universities (Appendix VI) to consider, develop and assess biogeochemical budgets for more than 30 estuaries in the region. The participating scientists contributed necessary data and knowledge about the estuarine systems, and identified additional sites for budget work based on existing databases. The outstanding success of the Workshop derived not only from the budget contributions to the LOICZ programme, but also from the opportunities to explore and discuss conceptual and methodological issues (Appendices I and III), to consider patterns of biogeochemical processes and to expand the network of researchers relating to LOICZ in the region.

The initial session of the Workshop dealt with the LOICZ approach to the global questions of horizontal fluxes of materials. An overview of the special nature of estuarine systems in Australia and a number of unifying concepts was presented by Dr Graham Harris (Appendix I) and supported by a description and discussion about the classification system that could be applied to the Australasian coastal systems (Appendix II).

Table 1.1 Budgeted Australasian sites, numerical designations, locations, sizes, water exchange times. (Class designations as follows: I--wet tropical; II--wet/dry tropical; III--wet/dry subtropical, IV--transitional; V--wet temperate; VI--dry temperate; VII--Mediterranean; VIII--dry tropical-subtropical; (S)--open shelf.)

Site no.	Class	Name	Long. (E = +)	Lat. (N = +)	Area (km ²)	Depth (m)	Exchange time (days)
1	I	Fly River	143.50	-8.50	500	5	13
2	II	Jardine	142.20	-11.15	5.6	1.4	8
3	II	Annan	145.27	-15.53	2.2	1.2	15
4	II	Daintree	145.43	-16.28	5.0	5.1	20
5	II	Moresby	146.12	-17.60	5.3	3.0	13
6	II (S)	Central Great Barrier Reef #	147.00	-18.00	14 000	37	nd
7	III	Caboolture	153.03	-27.15	2.1	2.2	410
8	III	Brisbane	153.17	-27.37	13	10.2	295
9	III	Logan	153.33	-27.68	3.6	4.9	412
10	III	Tweed	153.55	-28.17	6.3	3.4	115
11	III	Brunswick	153.55	-28.53	1.3	0.7	43
12	III	Richmond	153.58	-28.88	10.1	5.7	85
13	III	Clarence	153.35	-29.43	26.2	6.1	125
14	III	Bellinger	153.03	-30.65	1.8	2.6	16
15	III	Nambucca	153.02	-30.65	4.6	2.6	55
16	III	Hastings	152.87	-31.42	4.9	4.1	26
17	III	Macleay	153.05	-30.90	6.9	4.1	41
18	III	Manning	152.50	-31.87	14.5	5.1	88
19	IV	Hawkesbury-Nepean	151.80	-32.90	34	3	15
20	IV	Lake Illawarra	150.80	-34.00	35	2	55
21	V (S)	Hauraki Gulf	175.00	-36.50	5800	16	58
22	V	Manukau	174.30	-37.00	317	4	16
23	V	Derwent	147.30	-42.90	172	16	10
24	V	Lake Victoria	147.00	-38.00	100	5	47
25	V	Port Phillip	145.00	-38.00	1900	13	290
26	VI	Spencer Gulf #	137.00	-34.30	21 700	21	246
27	VII	Wilson Inlet #	117.30	-35.00	48	2.5	142
28	VII	Cockburn Sound	115.80	-32.20	114	12	150
29	VII	Swan Canning	115.90	-32.00	33	5	17
30	VIII	Shark Bay #	114.00	-26.00	4300	7	360

= existing site budgets on LOICZ website

nd = not determined

Table 1.2 Budgeted Australasian site numbers, class designations, and land (including atmosphere) nutrient loads.

Site no.	Class	DIP load	DIN load	Δ DIP	Δ DIN	Δ DOP	Δ DON
		$\text{mmol m}^{-2} \text{ yr}^{-1}$					
1	I	13	1577	39	-60	-4	409
2	II	21	595	33	-329	-29	-913
3	II	17	355	-5	9	-5	-1400
4	II	19	815	-2	-43	10	-1894
5	II	13	1567	-15	-456	0	0
6	II (S)	2	51	-4	-64		
7	III	201	2077	-83	366	14	620
8	III	927	7973	-136	922	-59	-755
9	III	1169	5759	-525	-1126	-75	6
10	III	166	712	-63	1137	-10	72
11	III	101	1612	-46	-225	-30	-15
12	III	531	3420	-26	-1194	-81	912
13	III	119	2396	-27	-38	-33	-188
14	III	319	3723	148	1038	47	2260
15	III	218	3355	-96	-536	-171	-404
16	III	325	7777	-153	-1501	-49	-1722
17	III	440	7110	-4	322	-176	-475
18	III	117	1120	-40	-161	-9	-135
19	IV	6	329	-44	-252		
20	IV	8	86	7	120		
21	V (S)	1	13	9	-91		
22	V	47	623	-33	524		
23	V	25	223	10	-159		
24	V	5	36	-6	-50		
25	V	28	173	-3	-172		
26	VI	0	0	-2	-1	0	-18
27	VII	3	65	-3	-33		
28	VII	202	1035	-193	1018		
29	VII	77	2585	4	843		
30	VIII	0	0	-1	-1		
	mean	171	1905	-42	-6	-37	-202
	std dev	278	2382	111	623	59	974
	median	38	925	-6	-47	-20	-77
	min	0	0	-525	-1501	-176	-1894
	max	1169	7973	148	1137	47	2260

Table 1.3 Budgeted site numbers, class designations and estimated (*nfix-denit*) (based on both total dissolved nutrients and dissolved inorganic nutrients, if available) and (*p-r*). (All stoichiometric flux calculations are based on an assumed Redfield C:N:P ratio of reacting particles.)

Site no.	Class	(<i>nfix-denit</i>) with DIN, DIP	(<i>nfix-denit</i>) with total N, P	(<i>p-r</i>)
		mmol m ⁻² yr ⁻¹		
1	I	-684	-211	-4134
2	II	-857	-1306	-3498
3	II	89	-1231	530
4	II	-11	-2065	212
5	II	-216	-216	1590
6	II (S)	0		424
7	III	1694	2090	8798
8	III	3098	3287	14 416
9	III	7274	8480	55 650
10	III	2145	2377	6678
11	III	511	976	4876
12	III	-778	1430	2756
13	III	394	734	2862
14	III	-1330	178	-15 688
15	III	1000	3332	10 176
16	III	947	9	16 218
17	III	386	2727	424
18	III	479	488	4240
19	IV	452		4664
20	IV	8		-742
21	V (S)	-235		-954
22	V	1052		3498
23	V	-319		-1060
24	V	46		636
25	V	-124		318
26	VI	31	13	212
27	VII	15		318
28	VII	4106		20 458
29	VII	779		-424
30	VIII	15		106
	mean	666	1172	4452
	std dev	1681	2400	11 731
	median	68	611	583
	min	-1330	-2065	-15 688
	max	7274	8480	55 650

Participants briefly outlined the estuarine systems and the status of constructed budgets for their contributing sites. The implications of any special conditions, such as episodic river flows and flushing, the rigour of supporting databases, and problems in deriving the budgets following the LOICZ approach were highlighted and discussed. Two systems (Richmond estuary in New South Wales, Swan Canning in Western Australia; see Appendix IV) were described and budgets derived using non-LOICZ approaches. These provided a comparison with companion evaluations which used the LOICZ approach and which are described in the body of the report.

The group moved from plenary to further develop the site budgets individually and in small working groups, returning to plenary sessions to discuss the budget developments and to debate points of approach and interpretation. Through this process, valuable contributions resulted which will assist the LOICZ methodology, including a consideration of limitations to the stoichiometric approach to interpretation of budgets and a cautionary note on the handling of spatial and temporal variations in systems (Appendix III).

Some 25 budgets were developed during the Workshop (Figure 1.1, Table 1.1); further advances were discussed for the budget assessments represented in four sites already posted on the LOICZ website (Central Great Barrier Reef, Spencer Gulf, Wilson Inlet and Shark Bay). In the subsequent three weeks, the detailed budgets and written descriptions were fine-tuned and provided for this report and for posting to the LOICZ Biogeochemical Budgets website (www.nioz.nl/loicz). Also, an additional site budget (for the Manukau Harbour, New Zealand) was developed and contributed.

The biogeochemical budgets reported here have been prepared usually by a group whose full authorship is duly acknowledged. The common element in the budget descriptions is the use of the LOICZ approach to budget development, which allows for global comparisons. The differences in the descriptive presentations reflect the variability in richness of site data, the complexity of the site and its processes, and the extent of detailed process understanding for the site. In some instances, the researchers have second-order and third-order details for the system and its biogeochemical functioning e.g., Port Phillip Bay, Victoria. Additional budgets are being developed for other estuarine systems in the region. It is anticipated that these, and the ones reported here, will be available from LOICZ in CD-ROM form by mid-1999. Support information for the various estuarine locations, describing the physical environmental conditions and related forcing functions including the history and potential anthropogenic pressure, is an important part of the budget information for each site. These data and their wider availability in electronic form (CD-ROM, LOICZ website) will provide opportunity for further assessment and comparisons, and potential use in consideration of wider scales of patterns in system response and human pressures.

The budget information for each site is discussed individually and reported in units that are convenient for that system (either as daily or annual rates). To provide for an overview and ease of comparison, the key data are presented in an “annualised” form and non-conservative fluxes are reported per unit area (Tables 1.2 and 1.3).

The budgeted Australasian sites occupy and represent a broad range of locations, size, and water exchange times (Table 1.1). The 35 degree latitudinal range covers tropical and sub-temperate climates (especially along the east coast of Australia), an east-west trend in aridity, and different states (continuous, ephemeral, monsoon-driven) and seasons of river flow. System sizes range from around 1 km² to thousands of km² in large gulf and open coastal shelf. All the systems are relatively shallow – a characteristic of the region (see Appendix I), and have water exchange times extending between about a week and a year.

This diversity of physical attributes provides opportunity for assessment of trends in patterns of estuarine performance and response to key forcing function, both natural and anthropogenic. Preliminary inspection of the budget and site data suggests some apparent trends:

1. A relationship between DIN and DIP loadings which is close to the Redfield ratio (16:1), and a latitudinal gradient in water column DIN:DIP ratios; higher in the tropical sites than the temperate sites.
2. A negative relationship between DIP loading and Δ DIP is apparent, such that the estuaries may be trapping, on average, about 30% of the DIP load. While the loading also forces sorption, the relationship strongly suggests that the elevation of inorganic P loading may be driving systems towards net autotrophy.
3. An apparent latitudinal trend wherein Δ DIP (or its stoichiometrically converted form, $[p-r]$) tends to show extreme values at mid-latitudes (between 25°S and 35°S). While these systems tend to be relatively dry, compared with both the lower and higher latitude systems, these latitudes are also the region of most of the heavy land use in the Australasian coastal region.
4. The majority of the temperate systems seem to be apparent net nitrogen fixers (according to the stoichiometric conversions used in the LOICZ budgets). Interestingly, the lack of a clear pattern in DIN suggests that it is too closely controlled by internal process of nitrogen fixation and denitrification to show much response to external load i.e., biotic aspects of the ecosystem type may prove far more important.

A larger data set for this region, in combination with other global data, will allow further testing and evaluation of these trend indicators and hypotheses. This work is in progress.

The Workshop was co-sponsored and hosted by CSIRO Land & Water which is the leading national scientific research agency in Australia addressing whole system, land-water interrelationships. LOICZ is grateful for this support and the opportunity to collaborate in working to mutual goals, and is indebted to Dr Graham Harris and staff for their contributions to the success of the Workshop. Dr Bradley Opdyke (and family) did sterling work as the local organiser for LOICZ, bringing together the group and ensuring that the daily interaction extended well into the evenings in conducive environments.

Cynthia Pattiruhu, LOICZ IPO, and Jan Marshall Crossland have contributed greatly to the preparation of this report. Finally, thanks are due to the participating scientists who made the effort to meet deadlines and to continue to interact beyond the meeting activities in order to ensure that the Workshop sum is greater than the individual products.

2. BUDGETS FOR AUSTRALIAN ESTUARINE SYSTEMS

2.1 QUEENSLAND AND NEW SOUTH WALES TROPICAL AND SUB-TROPICAL SYSTEMS

The following two sections represent parts of a general comparison among estuaries in tropical and subtropical Australia, under the direction of Bradley Eyre. Most of these estuaries are very small. However, they typify the river mouths of many tropical and subtropical Australian rivers, and the collection of numerous sites relatively close to one another provides an unusual opportunity for detailed comparison. Therefore, rather than present each estuary individually, the sites are grouped into Tropical and Sub-tropical systems. The data are summarised, within these two groups, in tabular form.

2.1.1 Tropical Systems

Bradley Eyre, Peter Pepperell and Peter Davies

Study Area Descriptions

The four tropical estuaries (Site No. 2. Jardine [142.20E, 11.15S]; 3. Annan [145.27E, 15.53S]; 4. Daintree [145.43E, 16.28S]; and 5. Moresby [146.12E, 17.60S]) are in north Queensland, Australia (see Figure 1.1). This region experiences a wet and dry tropical climate, with a pronounced wet season between December and May (summer) and a dry season for the remainder of the year. These tropical estuaries do not receive sewage treatment plant (STP) inputs. The physical characteristics of each catchment and estuary are summarised in Table 2.1. Further details can be found in Eyre (1994) and Eyre and Balls (in press).

Table 2.1 General characteristics of the tropical estuarine systems and their catchments.

System	Catchment Area km ²	Ann. Rain mm	Runof Coeff.	Ann. Runoff 10 ⁶ m ³	Length km	Area km ²	Mean depth m	Vol 10 ⁶ m ³	% nat. veg.	% other veg.
Jardine	2900	1740	0.35	1769	9	5.6	1.4	7.8	100	0
Annan	750	1820	0.48	653	16	2.2	1.2	2.7	90	10
Daintree	2125	2020	0.57	2444	26	5.0	5.1	25.6	74	26
Moresby	125	3700	0.54	250	20	5.3	3.0	15.9	48	52

Methods

Although the general methodology used here generally accords with the LOICZ methodology (Gordon *et al.* 1996), the details differ as described in Section 2.1.2 Sub-tropical Systems (Eyre and Pepperell).

Results

Table 2.2 summarises the water exchange times in these systems, and Table 2.3 summarises the fluxes of dissolved inorganic and organic phosphorus and nitrogen. Most of the nonconservative TDP and TDN flux represents DIP and DIN. It should be noted

that both the exchange times and the nonconservative fluxes are somewhat deceptive. Because of the way in which data for the budgets are collected, these represent samples between major runoff events, which rapidly flush the systems and wash particulate materials out of the systems. Even with this caveat, all of these systems tend to exhibit very short exchange times (1-3 weeks).

Table 2.2 Exchange time estimates for the tropical estuaries.

System	Estuary Volume (10^6 m^3)	Exchange Time (Days)
Jardine	7.8	8
Annan	2.7	15
Daintree	25.6	20
Moresby	15.9	13

The data summarised in Table 2.3 can be used according to the LOICZ Guidelines to calculate estimates of nitrogen fixation minus denitrification (*nfix-denit*) and primary production minus respiration (*p-r*). These estimates are summarised in Table 2.4. In the case of (*nfix-denit*), the calculations using total dissolved N and P are compared with calculations using only DIN and DIP.

Table 2.3 Inputs, oceanic exchange and nonconservative flux of dissolved inorganic and organic P and N for the tropical estuaries.

DIP							
Estuary	F_{diffuse} kmol yr ⁻¹	F_{atmos} kmol yr ⁻¹	F_{urban} kmol yr ⁻¹	F_{STP} kmol yr ⁻¹	F_{ocean} kmol yr ⁻¹	ΔDIP kmol yr ⁻¹	ΔDIP mmol m ⁻² d ⁻¹
Jardine	116	0	0	0	-296	180	0.09
Annan	38	0	0	0	-28	-10	-0.01
Daintree	93	0	0	0	-82	-11	-0.01
Moresby	65	6	0	0	11	-82	-0.04
DOP							
Estuary	F_{diffuse} kmol yr ⁻¹	F_{atmos} kmol yr ⁻¹	F_{urban} kmol yr ⁻¹	F_{STP} kmol yr ⁻¹	F_{ocean} kmol yr ⁻¹	ΔDOP kmol yr ⁻¹	ΔDOP mmol m ⁻² d ⁻¹
Jardine	139	0	0	0	13	-152	-0.08
Annan	16	0	0	0	-6	-10	-0.01
Daintree	121	0	0	0	-168	48	0.03
Moresby	0	0	0	0	0	0	0.00

DIN							
<u>Estuary</u>	F _{diffuse}	F _{atmos}	F _{urban}	F _{STP}	F _{ocean}	ΔDIN	ΔDIN
	kmol yr ⁻¹	kmol yr ⁻¹	kmol yr ⁻¹	kmol yr ⁻¹	kmol yr ⁻¹	kmol yr ⁻¹	mmol m ⁻² d ⁻¹
Jardine	3334	0	0	0	-1555	-1779	-0.9
Annan	781	0	0	0	-800	19	0.0
Daintree	4074	0	0	0	-3859	-215	-0.1
Moresby	8305	173	0	0	-6061	-2417	-1.2
DON							
<u>Estuary</u>	F _{diffuse}	F _{atmos}	F _{urban}	F _{STP}	F _{ocean}	ΔDON	ΔDON
	kmol yr ⁻¹	kmol yr ⁻¹	kmol yr ⁻¹	kmol yr ⁻¹	kmol yr ⁻¹	kmol yr ⁻¹	mmol m ⁻² d ⁻¹
Jardine	17 917	0	0	0	-12 650	-5268	-2.5
Annan	5558	0	0	0	-2478	-3081	-3.8
Daintree	11 322	0	0	0	-1852	-9469	-5.2
Moresby	0	0	0	0	0	0	0.0

Table 2.4 Calculations of (*nfix-denit*) and (*p-r*) for the tropical systems. [For (*nfix-denit*) calculations are based on both dissolved inorganic N and P and total dissolved N and P, assuming a Redfield N:P ratio of 16:1 for the reacting organic matter. For (*p-r*), calculations assume a Redfield C:P ratio of 106:1 for the reacting organic matter]

System	(<i>nfix-denit</i>) inorganic N, P mmol m⁻² d⁻¹	(<i>nfix-denit</i>) total dissolved N, P mmol m⁻² d⁻¹	(<i>p-r</i>) mmol m⁻² d⁻¹
Jardine	-2.3	-3.7	-9.3
Annan	0.2	-3.4	1.3
Daintree	0.0	-5.6	0.6
Moresby	-0.6	-0.6	4.5
mean ± s. d.	-0.7±1.1	-3.3±2.1	-0.7±6.0
median	-0.3	-3.6	+1.0

There is a suggestion of weak net denitrification, whether dissolved inorganic nutrients or total dissolved nutrients are used for the calculation. The trend is somewhat more consistent with the total dissolved nutrients. Calculated (*p-r*) is near 0.

2.1.2 Sub-tropical Systems

Bradley Eyre and Peter Pepperell

Study Area Descriptions

The twelve sub-tropical estuaries (Site No. 7. Caboolture [153.03E, 27.15S]; 8. Brisbane [153.17E, 27.37S]; 9. Logan [153.33E, 27.68S]; 10. Tweed [153.55E, 28.17S]; 11. Brunswick [153.55E, 28.53S]; 12. Richmond [153.58E, 28.88S]; 13. Clarence [153.35E, 29.43S]; 14. Bellinger [153.03E, 30.65S]; 15. Nambucca [153.02E, 30.65S]; 16. Macleay [153.05E, 30.90S]; 17. Hastings [152.87E, 31.42S]; 18. Manning [152.50E, 31.87S]) are in south-east Queensland and northern New South Wales, Australia. The locations of the sites are shown on Figure 1.1. This region experiences a wet and dry sub-tropical climate. During the summer months (October - April), moist unstable sub-tropical maritime airflows prevail, bringing heavy rainfalls and thunderstorms. During winter months (May - September) relatively stable anticyclonic air pressure systems with clear skies and light winds predominate. The physical characteristics of each catchment and estuary are summarised in Table 2.5, and further details can be found in Pont (1998).

Table 2.5 General characteristics of the sub-tropical estuarine systems and their catchments.

System	Catch. Area km ²	Ann. Rain mm	Runoff Coeff.	Ann. Runoff 10 ⁶ m ³	Length km	Area km ²	Mean depth m	Vol 10 ⁶ m ³	% nat. veg.	% other veg.
Caboolture	401	1210	0.24	116	19	2.1	2.2	4.7	31	69
Brisbane	13 560	1152	0.09	1410	75	13.0	10.2	132.5	21	79
Logan	3540	1534	0.12	651	39	3.6	4.9	17.8	25	75
Tweed	1068	1716	0.29	532	33	6.3	3.4	21.6	30	70
Brunswick	213	1777	0.30	114	11	1.3	0.7	0.9	10	90
Richmond	6861	1849	0.23	2916	41	10.1	5.7	57.4	41	59
Clarence	22 446	1075	0.20	4826	62	26.2	6.1	158.7	55	45
Bellinger	1128	1471	0.26	431	17	1.8	2.6	4.7	54	46
Nambucca	1326	1354	0.25	450	29	4.6	2.6	11.8	25	75
Hastings	10 686	1217	0.26	3377	30	6.9	4.1	28.4	48	52
Macleay	3715	1310	0.14	680	30	4.9	4.1	20.1	55	45
Manning	8195	1276	0.26	2721	41	14.5	5.1	74.0	76	24

Methods

Nutrient delivery to the estuary was split into two categories, during floods and other times of the year, and these two categories were treated differently. During floods, the estuarine basins are completely flushed with freshwater or at least rapidly flushed and as such, dissolved nutrients behave conservatively and are most probably completely flushed through the estuarine basin to the continental shelf (see Eyre and Twigg 1997; Eyre 1998). The flood event intervals (I) were separated using the formula $I = A^{0.2}$ days after the peak of the hydrograph, where A is the area above the gauging stations.

A proportion of dissolved nutrients delivered during other times of the year (i.e. not in floods) are retained and transformed within the estuary with the remaining nutrients transported to the ocean. The transport, retention and transformation flux of nutrients was quantified as:

$$F_{\text{diffuse}} + F_{\text{point}} + F_{\text{urban}} + F_{\text{atmosphere}} + F_{\text{input}} + F_{\text{removal}} = F_{\text{ocean}}$$

where:	F_{diffuse}	=	diffuse loading
	F_{point}	=	point source loading
	F_{urban}	=	urban loading
	$F_{\text{atmosphere}}$	=	atmospheric loading
	F_{input}	=	input flux within the estuary
	F_{removal}	=	removal flux within the estuary
	F_{ocean}	=	flux out of the estuary to the ocean

Each estuary was sub-divided into 15 to 30 boxes depending on the homogeneity of the estuarine sections. Water, salt and material budgets were calculated for each box using the LOICZ Biogeochemical Modelling Guidelines (Gordon *et al.* 1996). The salinity of each box was calculated from salinity profiles taken along the estuaries and the average material concentrations were obtained from a 4th order polynomial fitted to the material data (see below, Estuarine Sampling program) plotted as a function of salinity. The $(F_{\text{input}} + F_{\text{removal}})$ is equivalent to ΔY in Gordon *et al.* (1996) and is given as:

$$F_{\text{input}} + F_{\text{removal}} = F_{\text{diffuse}} + F_{\text{point}} + F_{\text{urban}} + F_{\text{atmosphere}} - F_{\text{ocean}}$$

F_{ocean} is equivalent to the sum $[V_R Y_R + V_X(Y_{\text{ocn}} - Y_{\text{sys}})]$ in Gordon *et al.* (1996). This term was calculated from the water, salt and material budgets.

Estuarine Sampling Program

Six sampling runs were undertaken in the sub-tropical estuaries (January, April/May, May, July/August, September and December) and two sampling runs were undertaken in the tropical estuaries (wet and dry seasons). Samples were collected at intervals of approximately 2 psu from seawater to freshwater along the axial salinity gradient in the estuary. Salinity profiles were also undertaken at each sample location.

Nutrient Loadings to the Estuary

Four major nutrient sources to the estuaries were quantified (diffuse source loading, point source loading as urban runoff and sewage effluent and atmospheric deposition).

Diffuse Source Loading (F_{diffuse}) to the estuary was calculated by integrating the product of flow-weighted concentrations and daily flows. The hydrographic response of floods in the catchments typically spans several days. Daily sampling was carried out during floods, with samples collected on rising and falling stages being considered sufficient to characterise loads. Fortnightly to monthly samples were collected during base flow conditions.

Point-Source Loading (F_{point}) of nutrients from sewage effluent discharges was calculated for the sewage treatment plants (STPs) discharging into each estuary by dividing annual STP loads by 365 (or 366) and multiplying by the number of days associated with each time period. The annual STP loads for these NSW estuaries had been previously estimated by Manly Hydraulics Laboratory (MHL) as part of a review of estuarine sewage outfalls in NSW (Phil Anderson, personal communication 1997). The annual STP loads for the sub-tropical south-east Queensland estuaries had been previously estimated as part of the Brisbane River and Moreton Bay Wastewater Management Study (Anonymous 1998). DIN and DIP loads were estimated by assuming that 75% of the TN and TP loads consisted of dissolved inorganic forms.

Urban runoff (F_{urban}) was calculated as monthly nutrient loading to the nine northern NSW estuaries using the formula:

$$A_{\text{ua}} * R * X * C_{\text{ur}}$$

where: A_{ua} = the urban area ;
 R = monthly rainfall;
 X = an average runoff coefficient for urban areas of similar density, 0.4;
 C_{ur} = an average nutrient concentration (TN: 1.4 mg l⁻¹; TP: 0.4 mg l⁻¹; NO₃: 0.5 mg l⁻¹; NH₄: 0.6 mg l⁻¹) adapted from other relevant urban runoff studies.

Urban runoff concentrations were estimated for Lismore, Mullumbimby and the lower Tweed area, as they are adjacent regional urban centres with similar rainfall patterns, total impervious surfaces, and traffic and population densities similar to the study systems. The monthly nutrient loading to the three south-east Queensland estuaries from urban runoff was derived from Anonymous (1998).

Atmospheric Deposition ($F_{\text{atmosphere}}$) was calculated as monthly nutrient loading using the formula:

$$A_{\text{e}} * R * C_{\text{ad}}$$

where: A_{e} = the surface area of the estuary ;
 R = rainfall;
 C_{ad} = the average monthly nutrient concentrations in rainfall collected at Lismore.

The use of atmospheric concentrations for Lismore was considered appropriate because it is in the lower Richmond catchment, which has similar land uses, population densities and climatic variables to the study systems. Atmospheric loadings to the tropical estuaries were derived from Eyre (1995).

Results

Table 2.6 summarises the water exchange times in these systems, and Table 2.7 summarises the fluxes of total dissolved phosphorus and nitrogen. Note the cautionary remarks made in the previous section (2.1.1) about the nature of the data collection as well as exchange times and nonconservative flux calculations. The exchange times for these systems during low flow periods tend to be very long.

Table 2.6 Exchange time estimates for the sub-tropical estuaries.

System	Estuary Volume (10^6 m^3)	Exchange Time (Days)
Caboolture	4.7	410
Brisbane	132.5	295
Logan	17.8	412
Tweed	21.6	115
Brunswick	0.9	43
Richmond	57.4	85
Clarence	158.7	125
Bellinger	4.7	16
Nambucca	11.8	55
Hastings	28.4	41
Macleay	20.1	26
Manning	74.0	88

Table 2.7 Inputs, oceanic exchange and nonconservative flux of dissolved inorganic and organic P and N in the sub-tropical estuaries.

DIP							
<u>Estuary</u>	F_{diffuse} kmol yr^{-1}	F_{atmos} kmol yr^{-1}	F_{urban} kmol yr^{-1}	F_{STP} kmol yr^{-1}	F_{ocean} kmol yr^{-1}	ΔDIP kmol yr^{-1}	ΔDIP $\text{mmol m}^{-2} \text{ d}^{-1}$
Caboolture	203	1	0	218	-247	-175	-0.23
Brisbane	1858	3	1647	8548	-10 286	-1770	-0.37
Logan	1320	2	412	2475	-2318	-1891	-1.44
Tweed	499	2	19	523	-649	-394	-0.17
Brunswick	80	1	13	37	-71	-60	-0.13
Richmond	5050	6	177	130	-5103	-260	-0.07
Clarence	2847	11	35	232	-2422	-703	-0.07
Bellinger	526	1	7	41	-841	266	0.40
Nambucca	757	2	33	213	-564	-441	-0.26
Hastings	1035	2	8	547	-840	-752	-0.42
Macleay	2586	3	23	425	-3010	-27	-0.01
Manning	1199	6	75	415	-1115	-580	-0.11

DOP							
<u>Estuary</u>	F_{diffuse} kmol yr ⁻¹	F_{atmos} kmol yr ⁻¹	F_{urban} kmol yr ⁻¹	F_{STP} kmol yr ⁻¹	F_{ocean} kmol yr ⁻¹	ΔDOP kmol yr ⁻¹	ΔTDOP mmol m ⁻² d ⁻¹
Caboolture	274	0	0	0	-303	30	0.04
Brisbane	5758	1	0	0	-4986	-772	-0.17
Logan	2820	1	0	0	-2551	-270	-0.20
Tweed	3054	1	-2	0	-2988	-64	-0.03
Brunswick	58	0	2	0	-21	-39	-0.08
Richmond	2684	2	25	0	-1896	-817	-0.22
Clarence	8963	3	5	0	-8096	-875	-0.10
Bellinger	296	0	1	0	-381	84	0.13
Nambucca	2195	0	5	0	-1414	-786	-0.47
Hastings	1917	0	1	0	-1678	-241	-0.14
Macleay	4425	1	3	0	-3215	-1213	-0.48
Manning	2258	1	10	0	-2142	-127	-0.02
DIN							
<u>Estuary</u>	F_{diffuse} kmol yr ⁻¹	F_{atmos} kmol yr ⁻¹	F_{urban} kmol yr ⁻¹	F_{STP} kmol yr ⁻¹	F_{ocean} kmol yr ⁻¹	ΔDIN kmol yr ⁻¹	ΔDIN mmol m ⁻² d ⁻¹
Caboolture	3621	44	0	696	-5129	769	1.0
Brisbane	36 547	325	18 098	48 673	-115 629	11 986	2.5
Logan	11 251	99	4498	4886	-16 681	-4053	-3.1
Tweed	3922	182	254	129	-11 648	7161	3.1
Brunswick	1575	39	182	299	-1803	-292	-0.6
Richmond	30 992	420	2391	739	-22 483	-12 059	-3.3
Clarence	60 592	655	468	1065	-61 788	-992	-0.1
Bellinger	6118	50	93	441	-8569	1868	+2.8
Nambucca	14 373	115	203	740	-12 965	-2466	-1.5
Hastings	35 725	265	110	2007	-30 701	-7406	-4.1
Macleay	47 639	178	304	940	-51 281	2220	0.9
Manning	14 117	351	457	1315	-13 904	-2336	-0.4
DON							
<u>Estuary</u>	F_{diffuse} kmol yr ⁻¹	F_{atmos} kmol yr ⁻¹	F_{urban} kmol yr ⁻¹	F_{STP} kmol yr ⁻¹	F_{ocean} kmol yr ⁻¹	ΔDON kmol yr ⁻¹	ΔDON mmol m ⁻² d ⁻¹
Caboolture	14 215	10	0	0	-15 228	1303	1.7
Brisbane	65 467	75	0	0	-55 723	-9819	-2.0
Logan	50 143	22	0	0	-50 188	23	0.0
Tweed	38 826	39	65	0	-39 385	454	0.2
Brunswick	1717	10	46	0	-1753	-19	-0.1
Richmond	86 647	107	611	0	-96 573	9208	2.5
Clarence	265 665	-73	120	0	-260 773	-4938	-0.5
Bellinger	14 081	10	24	0	-18 183	4068	6.2
Nambucca	17 051	26	52	0	-15 270	-1858	-1.1
Hastings	55 410	62	28	0	-47 060	-8440	-4.8
Macleay	145 052	39	78	0	-141 947	-3223	-1.3
Manning	39 820	70	117	0	-38 043	-1963	-0.4

The data summarised in Table 2.7 can be used according to the LOICZ Guidelines to calculate estimates of nitrogen fixation minus denitrification (*nfix-denit*) and primary production minus respiration (*p-r*). These estimates are summarised in Table 2.8. In the case of (*nfix-denit*), the calculations using total dissolved N and P are compared with calculations using only DIN and DIP.

These estimates indicate that most of the systems are slight net nitrogen fixers and net autotrophic. Additional inter-annual estimates for the Richmond River are given in Appendix IVA, using a non-LOICZ (but adapted) approach.

Table 2.8 Calculations of (*nfix-denit*) and (*p-r*) for the subtropical systems. [For (*nfix-denit*), calculations are based on both dissolved inorganic N and P and total dissolved N and P, assuming a Redfield N:P ratio of 16:1 for the reacting organic matter. For (*p-r*) calculations assume a Redfield C:P ratio of 106:1 for the reacting organic matter.]

System	(<i>nfix-denit</i>) inorganic N, P mmol m ⁻² d ⁻¹	(<i>nfix-denit</i>) total dissolved N, P mmol m ⁻² d ⁻¹	(<i>p-r</i>) mmol m ⁻² d ⁻¹
Caboolture	4.7	5.7	24.2
Brisbane	8.5	9.0	39.5
Logan	19.9	23.2	152.5
Tweed	5.9	6.5	18.2
Brunswick	1.4	2.7	13.4
Richmond	-2.1	3.9	7.5
Clarence	1.1	2.0	7.8
Bellinger	-3.6	0.5	-42.9
Nambucca	2.7	9.1	27.8
Hastings	2.6	0.0	44.6
Macleay	1.1	7.5	1.1
Manning	1.3	1.3	11.6
mean ± s.d.	+3.6±6.1	+6.0±6.3	+25.4±45.7
median	+2.0	+4.8	+19.7

2.2 HAWKESBURY-NEPEAN RIVER, NEW SOUTH WALES

G.P. Bickford and S.V. Smith

A nutrient budget has been prepared for the Hawkesbury-Nepean River using the LOICZ methodology (<http://data.ecology.su.se/MNODE/Methods/STOCH.HTM>). The significant diversion from that methodology is that conductivity is used as the surrogate tracer for the salinity budget. Otherwise the methodology was followed. The budgets are divided into 'financial year' (July 1-June 30), for 1995-1996 and 1996-1997, because that is how the data are tabulated. The two years are reported separately to give some sense of interannual variability.

Site Area Description

The Hawkesbury-Nepean River system [Site No. 19.; 151.80E, 32.90S] is about 300 km long and drains a catchment area of approximately 22 000 km² (Figure 2.1; see Figure 1.1). The Hawkesbury-Nepean system can be divided into a fluvial and an estuarine section, with the mainstream receiving inflows from 14 large tributaries (SPCC 1983). Many of the tributary watersheds to the north and west are undeveloped, rugged and forested, whereas the flatter terrain to the west and south-west of Sydney, originally pastoral and agricultural land, is now generally urbanised.

The Nepean River, the fluvial section of the river, flows in a northerly direction from its headwaters in the Illawarra Range and is joined by the Avon, Cordeaux and Cataract rivers. Flowing north-west, it is joined by the Warragamba River and further downstream by Erskine and Glenbrook creeks before joining the Hawkesbury River at the Grose River junction near North Richmond.

The Hawkesbury River, the estuarine section of the river system, extends 140 km from the confluence of the mainstream of the Nepean and the Grose River to its outlet at Broken Bay. The Hawkesbury River is the largest section of water within the catchment. Saline intrusion occurs in the Hawkesbury River, but it is limited to reaches downstream of the Colo River junction (83 km from the coast) (SPCC 1983). Tidal movement in the Hawkesbury River is apparent upstream as far as its junction with the Grose River. A number of major tributaries, including the MacDonal and Colo Rivers and Mangrove, Cattai, Berowra and Cowan creeks flow into the Hawkesbury River between Windsor and Brooklyn.

Flow within the Hawkesbury-Nepean River system is significantly greater than the flow from the combined sewage treatment plant (STP) discharges. Based on average flow conditions, the contribution of STP discharges to the net flow of the Hawkesbury River ranges from approximately seven percent just below the confluence with the Grose River to 18 percent just below the junction with Eastern Creek. The contribution of STP discharge to flows in the Nepean River ranges from one percent at Penrith Weir, just above the junction with Boundary Creek, to eight percent just below the confluence with the unnamed creek into which the Winmalee STP discharges. Two STPs discharge into the upper reaches of Berowra Creek. This arm of the Hawkesbury-Nepean system can be separately budgeted, but that budget is not presented here.

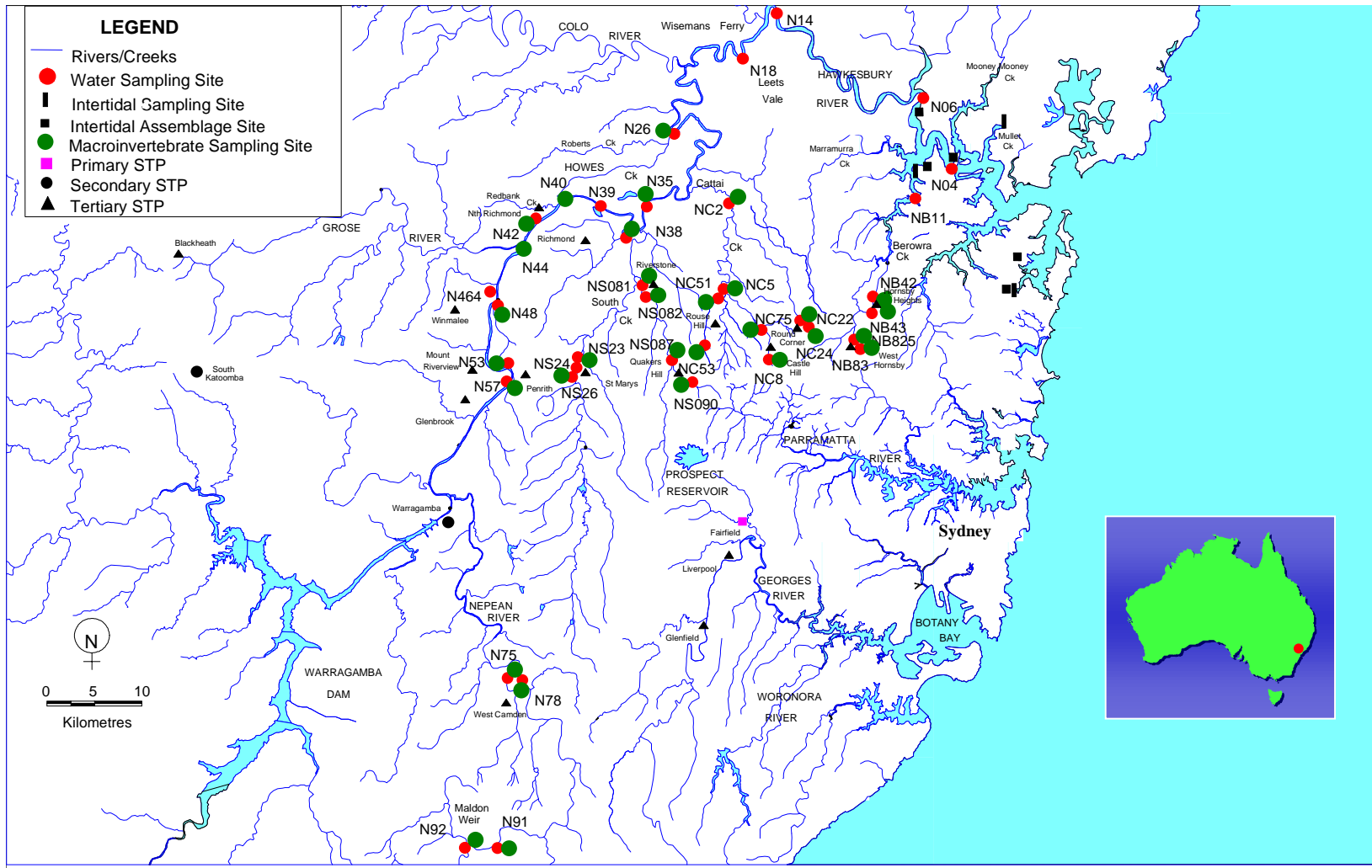

Figure 2.1 Hawkesbury-Nepean River system.

Flow in some tributary streams to the Hawkesbury-Nepean River, such as South, Eastern, Cattai and Matahil creeks, is dominated by STP effluent under dry weather conditions. The effluent contribution to flow ranges from a low of approximately six percent in the Warragamba River (below the dam) to a high of nearly 100 percent at Matahil Creek and Eastern Creek (downstream of the Riverstone and Quakers Hill STP discharges). Under wet weather conditions flow in these streams increases dramatically, and often the stream flow greatly exceeds the STP discharges.

The Hawkesbury-Nepean River system catchment can be divided into five different physiographic regions:

- (1) the Blue Mountains Plateau;
- (2) the Cumberland Lowlands;
- (3) the Woronora Plateau;
- (4) the MacDonald Ranges; and
- (5) the Hornsby Plateau (Sydney Water 1991).

The Blue Mountains Plateau comprises most of the western side of the Hawkesbury-Nepean River from the Nepean Dam to Wisemans Ferry. It consists of a deeply incised, Hawkesbury sandstone surface that overlies Narrabeen sandstone. Numerous creeks draining the area flow into two of the primary tributaries to the Hawkesbury-Nepean River system, specifically the Grose and Coxs rivers. The vegetation consists mainly of open forest and woodland and is dominated by a variety of *Eucalyptus* species. Areas of heath occur on the exposed clifftops and areas of closed forest may be found in the deep valleys and protected slopes.

The Cumberland Lowlands extend eastward from the Blue Mountains Plateau and, with the exception of the Razorback Range, consist of low-lying, gently undulating plains and low hills on Wianamatta Group shales and sandstones. Stretching east of the Hawkesbury-Nepean River system, the Cumberland Lowlands are flanked by the Woronora Plateau in the south, the Hornsby Plateau in the north-east and MacDonald Ranges in the north-west. It is an extensive floodplain area that includes the drainage catchment of South and Eastern creeks.

The region is comprised of creeks and their associated floodplains, alluvial terraces, and some intermediate slopes and undulating land. Very little original vegetation remains as a result of land clearing for agricultural and/or residential use. Open forest, woodland, riverine and pasture are the primary vegetation types found in the region.

The Woronora Plateau lies east and south of the Cumberland Lowlands. It is a deeply dissected sandstone plateau with Wianamatta Group shales occurring as thin lenses. Upland swamps are a common feature towards the coast. The major vegetation formation found in the Woronora Plateau, which occupies most the Sydney Water catchment areas at Nepean, Avon, Cordeaux and Cataract dams, is woodland and open forests. Heaths, including paroo lily, snake grass, and fuller shrubs (she-oak and heath banksia) also grow on the Woronora Plateau.

The MacDonalld Ranges are located in the north-east and consist of steep, rugged hills with narrow crests and valleys on Hawkesbury sandstone. Low, open forests of Sydney peppermint, *Eucalyptus piperita* and smooth-barked apple, *Angophora costata*, inhabit the steeper slopes of the MacDonalld Ranges, whilst the drier ridges support a low woodland dominated by red bloodwood, scribbly gum and narrow-leaved stringy bark gum.

The Hornsby Plateau, which is similar in form to the Woronora Plateau, is dominated by undulating to rolling plateau surfaces on Hawkesbury sandstone with Wianamatta Group shale caps on some crests. Areas of natural vegetation are generally represented by either national parks or Sydney Water catchment areas.

The Hawkesbury-Nepean River system is used for a variety of agricultural, industrial and recreational activities. The upper river reaches have been dammed and supply much of Sydney's drinking water, plus lesser amounts used for agriculture, industry and other needs. The river is also used for both primary (e.g., swimming) and secondary (e.g., boating) recreation. The number of people participating in these activities is likely to increase with additional future urban development.

Over 60 percent of the Hawkesbury-Nepean River system catchment is forested; it includes parts of nine national parks. Agricultural land comprises approximately 30 percent of the area, supporting activities such as cattle and sheep grazing, dairying, irrigated horticultural crops and intensive pig and poultry production; less than 10 percent is developed for urban and industrial use (Sydney Water 1991).

Industrial development within the Hawkesbury-Nepean River system is limited and generally located within sewage catchments served by the West Camden, Penrith and St Marys STPs (NSW EPA 1994). Industrial discharges to the sewer system are regulated by Sydney Water's Trade Waste Policy. The primary industries in the region include textiles, paint production, electroplating and metal finishing and the manufacture of pharmaceuticals and organic chemicals. A few industries between Menangle and Spencer are involved with the extraction of sand, gravel and other materials. Extraction of sand and gravel is concentrated in the Agnes Banks/ Londonderry and Penrith Lakes areas, while extraction from the river bed material is currently only undertaken at Windsor, Freemans Reach and Menangle. Coal mining also occurs in the upstream areas.

The climate of the Hawkesbury-Nepean catchment is strongly influenced by the Tasman Sea to the east and the Blue Mountains to the west (Sydney Water 1991). The headwaters of the Cox, Grose, Nepean and Nattai rivers and the coastal area near Broken Bay receive the highest rainfalls (annual rainfall ranges from 1000 to 1600 mm). Most of the remaining catchment is located within a rain shadow created by the higher coastal plateau; here annual rainfall ranges from 650 to 750 mm (Sydney Water 1991).

Throughout the region, rainfall occurs primarily in the summer with an average summer maximum of 261 mm at Penrith, ranging to a winter low of 154 mm at Richmond. Rain

falls over the region about 10-11 days per month throughout the spring and summer, but decreases to about 6 days per month in winter.

Diurnal and seasonal temperature ranges within the area vary considerably. Maximum summer temperatures average between 26-28°C (maximum 40°C), while minimum winter temperature averages between 2.6-5.9°C (minimum -5°C). Prevailing winds originate from the north-east in spring and summer and from the south-west in autumn and winter (Sydney Water 1991).

Sewage Treatment Plants

In the late 1980s a strategy was developed to reduce the impacts of STPs by reducing the phosphorus levels, oxygen demand and ammonia levels of the effluent. Upgrades to treatment processes ensured that the levels of phosphorus were lowered, thereby reducing eutrophication of the receiving waters. Nitrification processes were installed at the STPs, which meant that the effluent was oxygenated and ammonia was transformed to oxidised nitrogen (mostly as nitrate) (NSW EPA 1994). More recent, additional upgrades at the STPs further reduce phosphorus and nitrogen levels in the effluent.

Data Sources

Monthly data are collected at a number of sites along the Hawkesbury-Nepean River and its tributaries. These data are for a range of dissolved nutrients and physico-chemical parameters. The averages of these data have been used to calculate the nutrient fluxes. Inflows from streams to the main river are gauged and daily flows have been used to calculate an average daily flow. Similarly, flows from sewage treatment plants are gauged each day. The loads of nutrients from the STPs have been calculated using these flows and the average annual nutrient concentrations obtained from daily nutrient monitoring data. A complete series of water, salt and nutrient budgets, including the stoichiometric analysis, is presented for financial year 1995-1996 (July 1-June 30). To give a sense of interannual variation in the budget results, a summary table is also presented for N and P fluxes in the year 1996-1997.

The river has been divided into several reaches representing the freshwater, fresh tidal and estuarine sections (see Figure 2.2). The fluxes from each reach of the river have been presented and it has been assumed that the river is well mixed in each reach.

Results

Complete budgetary data are presented for the 1995-1996 financial year, using annual mean data (Figures 2.3-2.5). There has been no attempt to determine the errors about these means. A summary table of non-conservative fluxes is presented for that year (Table 2.9), as well as 1996-1997 (Table 2.10). The DIP and DIN budgets for the two years are summarised in Tables 2.9 and 2.10.

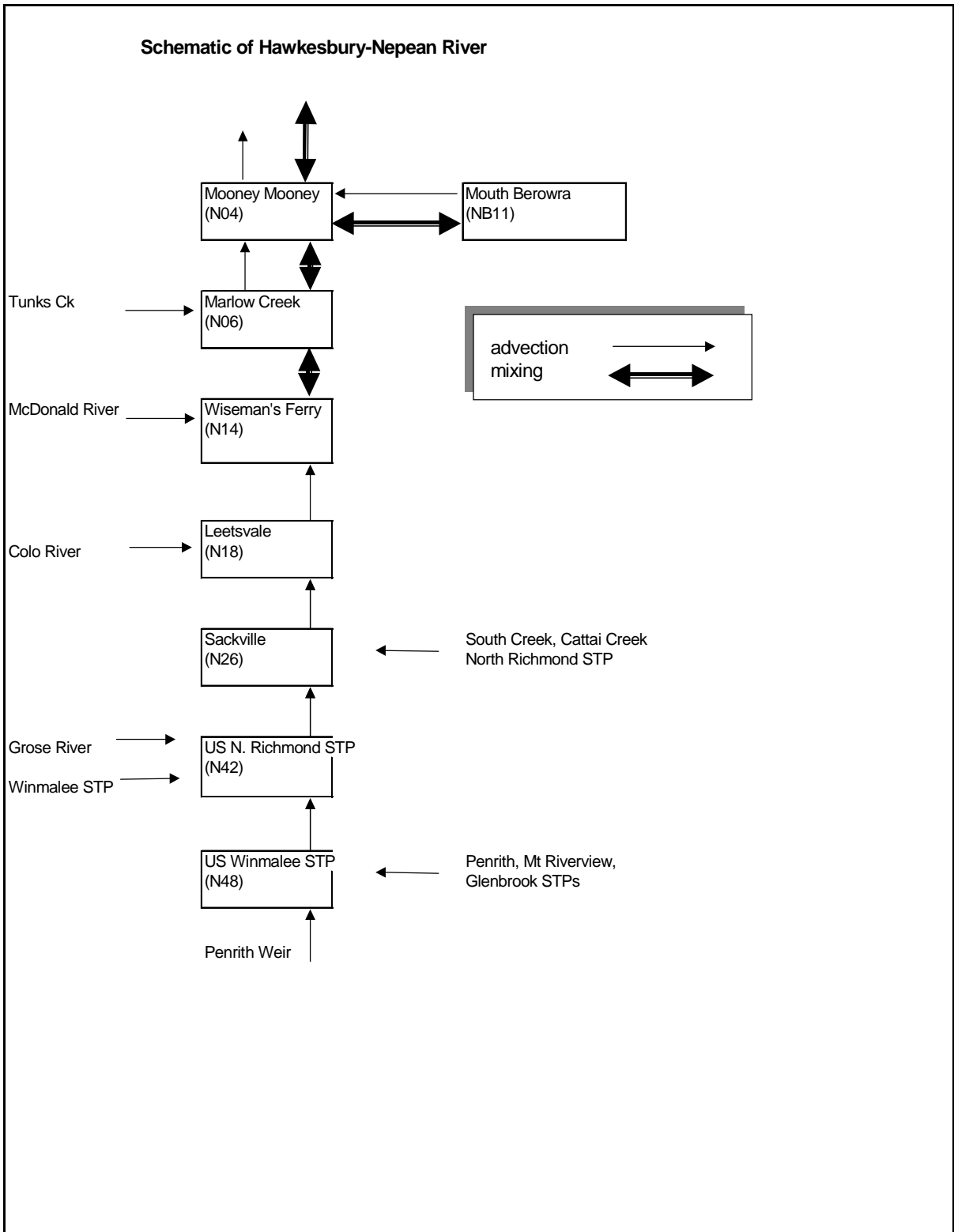

Figure 2.2 Schematic diagram for the Hawkesbury-Nepean River system.

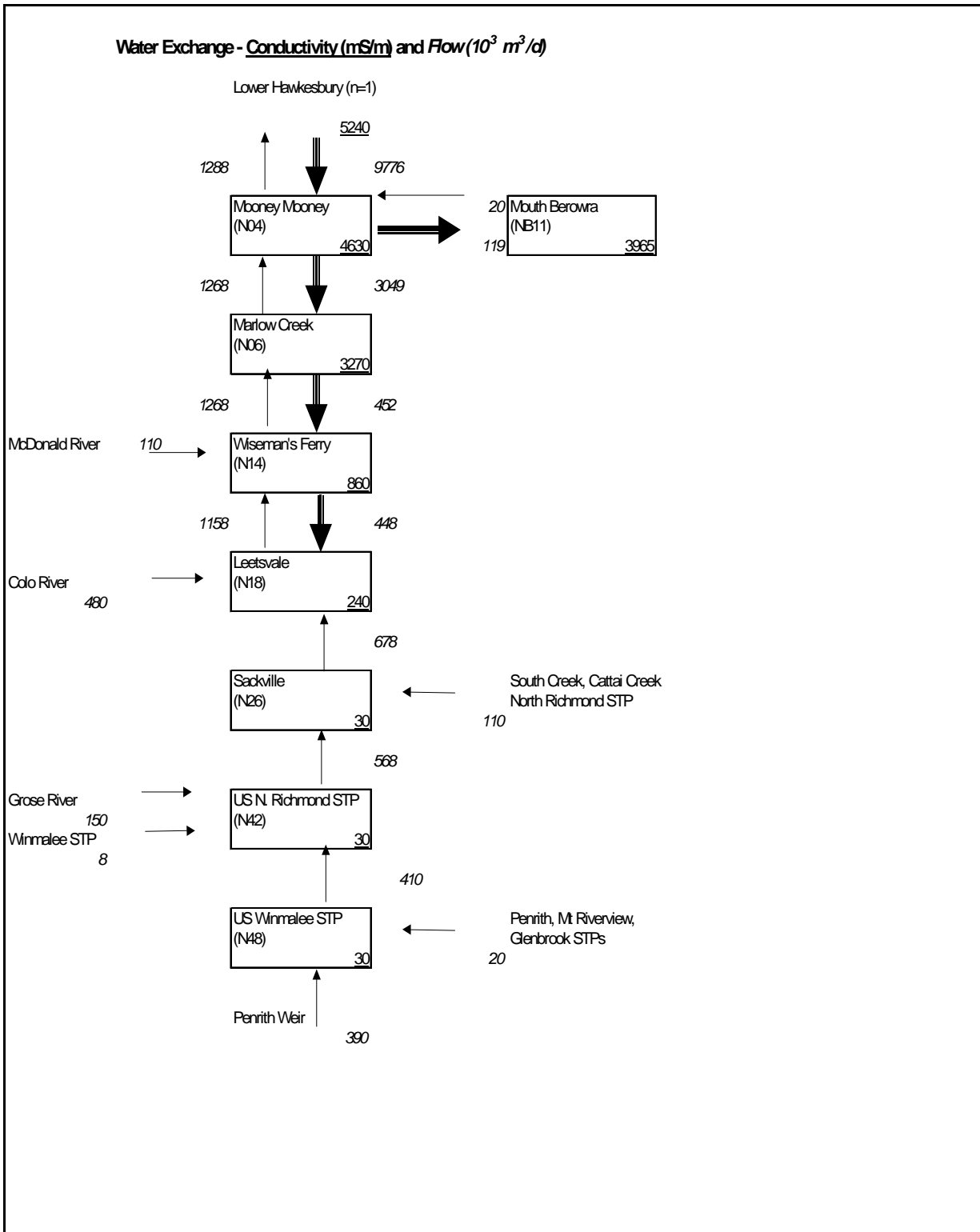

Figure 2.3 Summary of the water and salt balance during 1995-1996, for the Hawkesbury-Nepean River system.

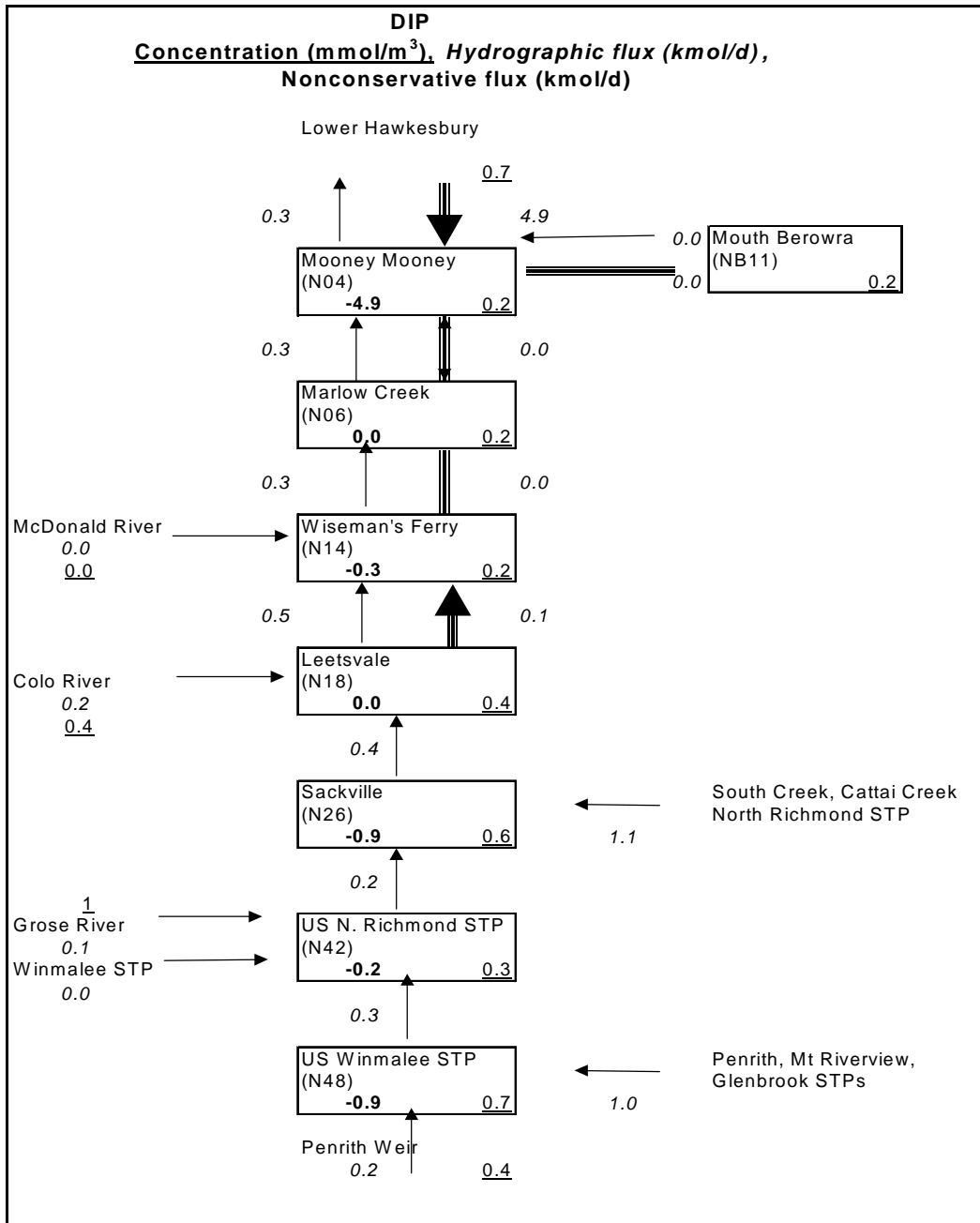

Figure 2.4 Summary of the DIP balance during 1995-1996, for the Hawkesbury-Nepean River system.

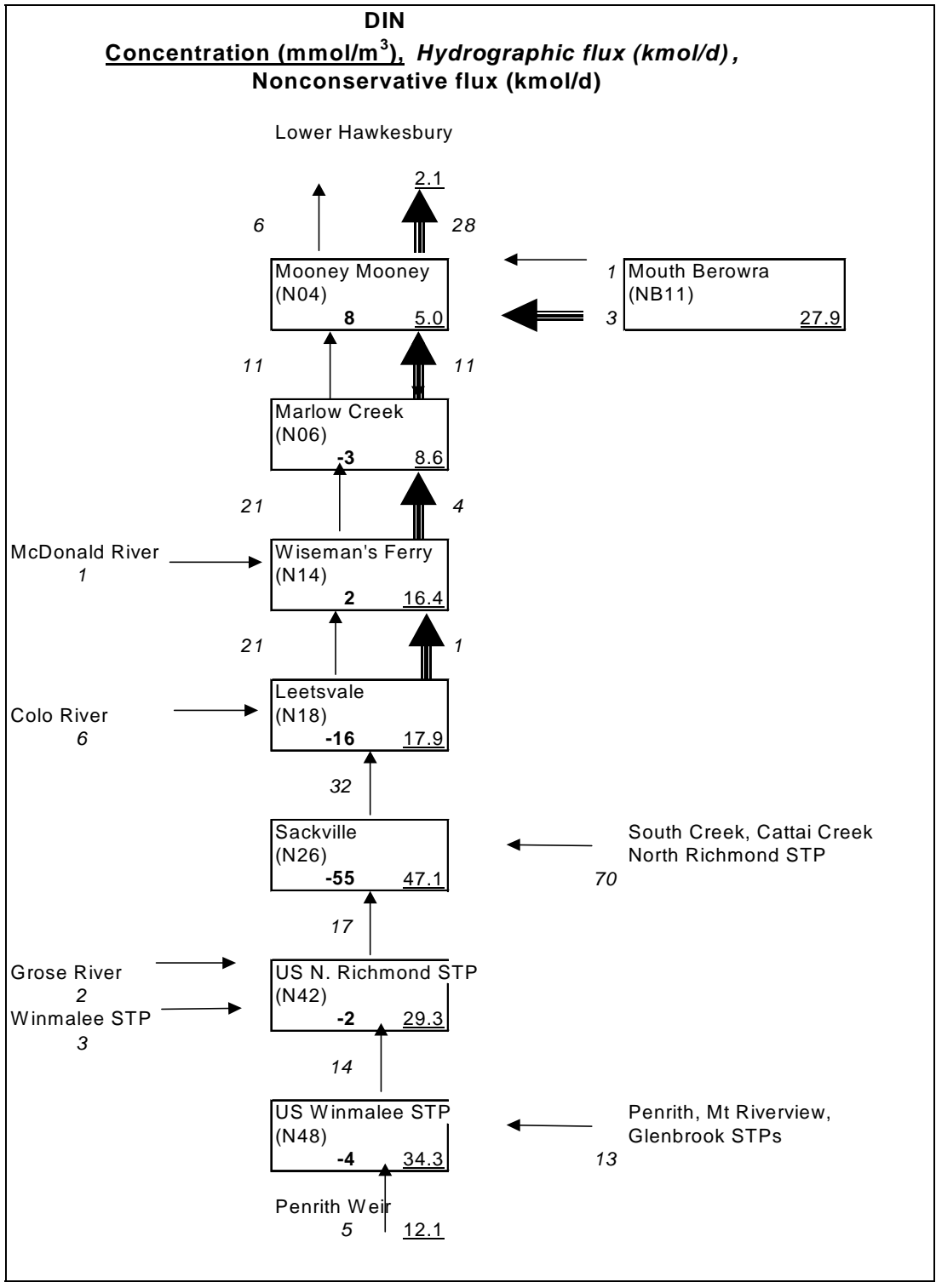

Figure 2.5 Summary of the DIN balance during 1995-1996, for the Hawkesbury-Nepean River system.

Table 2.9 Non-conservative DIP and DIN fluxes in the Hawkesbury-Nepean River system for the year 1995-1996. (Biogeochemical performance is inferred from LOICZ stoichiometric arguments.)

Location	DP kmol d ⁻¹	DN kmol d ⁻¹	(p-r) kmol d ⁻¹	(nfix-denit) kmol d ⁻¹
(N04)	-4.9	8	523	87
(N06)	0.0	-3	0	-3
(N14)	-0.3	2	32	7
N18	0.0	-16	0	-16
N26	-0.9	-55	95	-41
N43	-0.2	-2	21	1
N48	-0.9	-4	95	10

↑
estuary
tidal fresh
↑
river

	Area km ²	DP mmol m ⁻² d ⁻¹	DN mmol m ⁻² d ⁻¹	(p-r) mmol m ⁻² d ⁻¹	(nfix-denit) mmol m ⁻² d ⁻¹
Lower estuary	25	-0.2	0.2	21	3.4
Upper estuary	9	0.0	-1.6	4	-1.0
River, Tidal fresh	10	-0.2	-6.8	24	-2.9

Table 2.10 Non-conservative DIP and DIN fluxes in the Hawkesbury Nepean River system for the year 1996-1997. (Biogeochemical performance is inferred from LOICZ stoichiometric arguments.)

Location	DP kmol d ⁻¹	DN kmol d ⁻¹	(p-r) kmol d ⁻¹	(nfix-denit) kmol d ⁻¹
(N04)	-3.5	-8	370	48
(N06)	0.2	38	-21	35
(N14)	-0.2	3	21	6
N18	0.1	-9	-11	-11
N26	-0.4	-59	42	-53
N43	-0.6	-4	64	6
N48	-0.9	-6	95	8

↑
estuary
tidal fresh
↑
river

	Area km ²	DP mmol m ⁻² d ⁻¹	DN mmol m ⁻² d ⁻¹	(p-r) mmol m ⁻² d ⁻¹	(nfix-denit) mmol m ⁻² d ⁻¹
Lower estuary	25	-0.1	1.2	14	3.3
Upper estuary	9	0.0	0.4	1	-0.5
River, Tidal fresh	10	-0.2	-7.7	22	-3.9

Stoichiometric inferences are presented for both the river and the estuarine system, although the river-based stoichiometry is unlikely to be realistic because of inorganic reactions in this region. Above Sackville, the major source of dissolved inorganic P is sewage treatment plants, with a relatively small contribution from non-point sources. Most of the discharged phosphate is taken up as either organic or inorganic particulates close to the sewage treatment plants. Only about 20% of the phosphate introduced to the river above Sackville is transported below Sackville. For the estuary itself, the major source of DIP is the coastal ocean rather than the sewage treatment plants. Above Sackville, the major source of nitrogen to the river is from the STPs (90%). About 20% of the N introduced to the river from non-point and STP sources reaches the estuary. Most of the remainder is interpreted to be lost to denitrification.

The calculated ($p-r$) result for the lower estuary over the two years averages $+18 \text{ mmol m}^{-2} \text{ d}^{-1}$, with minor interannual variability. The upper estuary ($p-r$) is near 0, and the rate averaged over the whole estuary for two years is $+14 \text{ mmol m}^{-2} \text{ d}^{-1}$. There is a strong suggestion of an internal source of N (nitrogen fixation) in the lower estuary. The possible source of this nitrogen may be from a significant area of mangroves in the lower estuary. The upper estuary is a slight nitrogen sink (denitrification). The whole-estuary average rate of ($nfix-denit$) is $+2.3 \text{ mmol m}^{-2} \text{ d}^{-1}$.

2.3 LAKE ILLAWARRA, NEW SOUTH WALES

Cathee Miller and John Morrison

Study Area Description

Lake Illawarra (Site No.20.; 150.83E, 34.50S) is located on the south-east coast of Australia, approximately 8 km south of central Wollongong (see Figure 1.1). Lake Illawarra is a Late Pleistocene barrier estuary, with the barrier causing restricted connection to the ocean via a channel of approximately 3.7 km in length, with an average width of less than 200 m (Figure 2.6). The channel is mobile in both location and cross section, due to natural coastal processes involving winds, waves and currents (Standing Committee on Public Works 1996). The lake entrance is heavily shoaled and closes intermittently. Engineering works are currently planned to maintain an open entrance (Lake Illawarra Authority (LIA), personal communication 1997).

Some system information on Lake Illawarra is given in Table 2.11.

Table 2.11 System data for Lake Illawarra

<i>Dimensions:</i>	
Maximum length:	7.3 km
Maximum width:	5.5 km
Surface area:	35 km ²
Foreshore length:	40 km
Maximum depth:	3.8 m
Average depth:	1.8 m
Volume:	63 x 10 ⁶ m ³
<i>Catchment:</i>	
Area	235 km ²
<i>Land uses:</i>	
Forest/undeveloped	87 km ²
Rural	94 km ²
Residential/ Commercial	54 km ²
<i>Main Freshwater Sources:</i>	
Macquarie Rivulet	39% of catchment
Mullet Creek	27%
Duck Creek	7%
Other creeks	27%
<i>Fisheries:</i>	
Finfish	140 000 kg yr ⁻¹ (mullet, flathead, bream, luderick)
Prawns	30 000 kg yr ⁻¹

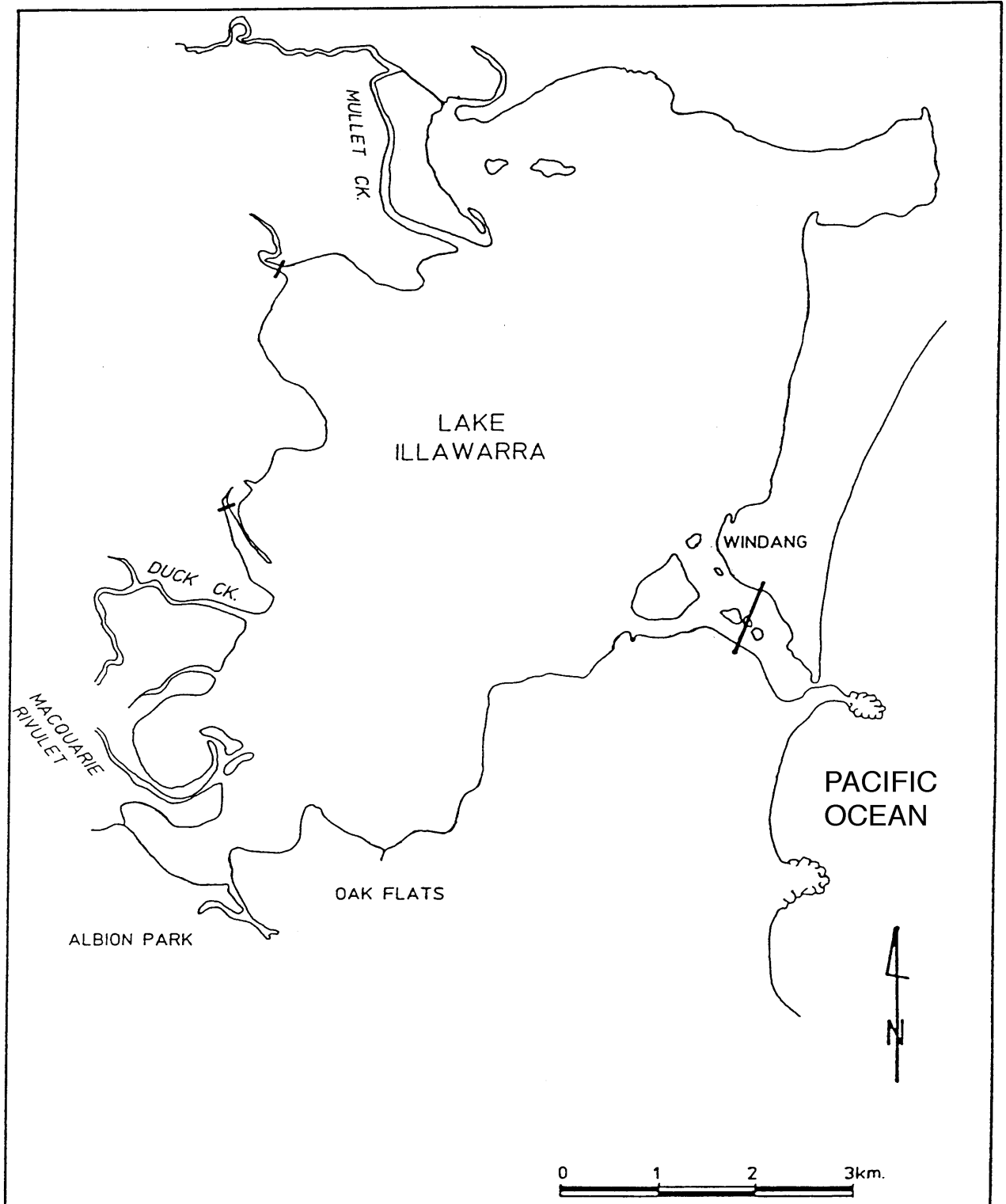

Figure 2.6 Site map of Lake Illawarra.

Land use within the catchment has changed greatly since first European settlement in the early 1800s, with the region shifting from predominantly agricultural to merging industrial, with relatively recent increases in urban and recreational usage of the area. The population living around the lake has increased from about 10,000 in the 1950s to about 95,000 in the late 1990s. The region is now completely seweraged, but septic tanks dominated until the mid-1980s with significant overflows into the lake during storms. Some overflow from sewage pumping stations has occurred and the Lake Illawarra Authority is attempting to manage overflow sites by the introduction of artificial wetlands.

The lake is very shallow and has been infilling since its creation, roughly 6000 years ago. It has a maximum depth of 3.5 m and an average depth of 1.8 m, the north-eastern segment being particularly shallow (Kanamori 1976). Hean and Nanson (1985) estimate that since European settlement 25 000-100 000 m³ of sediment are transported to the lake floor annually. Sediment analysis has shown this is up to 50 times greater than prior to European settlement.

The volume of water in Lake Illawarra is estimated to be 6.3×10^7 m³. Kanamori (1976) estimated the volume of flood and ebb tide to be 1.9×10^5 m³ and 7.8×10^5 m³ respectively, giving a mean volume of 4.9×10^5 m³, which accounts for 0.8% of the lake's volume. Therefore, allowing for tidal exchange only, he estimated the turnover rate of the lake to be 62.5 days. This is a gross simplification, not taking into account freshwater inflows, tidal variation, tidal penetration and entrance conditions.

The tidal range in the lake proper varies from 0.03 m under a heavily-shoaled entrance to 0.1 m under scoured-entrance conditions for an average ocean range of 1.1 m (Kanamori 1976). A 1.83 m tide recorded at Port Kembla showed a fluctuation of only 2.5 cm at Windang Bridge and was barely noticeable beyond Berkeley boat harbour on the south coast of the Lake, because of elevated lake water level compared with the sea (this elevation is 25-30 cm).

The area is classified as a temperate coastal environment, with temperatures moderated by the ocean. The expected rainfall in the area depends mainly on elevation. Average rainfall levels at Port Kembla to the north of the lake and Albion Park to the south are 1 151 and 1 231 mm (National Environmental Consulting Services 1997). Rainfall on the south-western escarpment, at an elevation of approximately 350 m, is about 1 600 mm per annum. Occasional heavy rainfall comes from mild cyclonic storms but otherwise rainfall is generally consistent throughout the year, with heaviest rain in late summer and autumn (Hean and Nanson 1985). Bureau of Meteorology rainfall data from 1974 to 1997 provides the following average rainfall percentages for the seasons:

Summer:	25.5%
Autumn:	30.1%
Winter:	21.8%
Spring:	22.6%

Storm events are an important feature of the catchment and lake behaviour, with major storm events occurring almost every year. Figure 2.7 shows the average monthly rainfall figures from 1974 to 1997, with maximum and minimum temperatures in Wollongong recorded from 1991. Figure 2.8 shows annual rainfall levels experienced in Wollongong, from 1974 to 1997 (Bureau of Meteorology, Canberra 1974 - 1997).

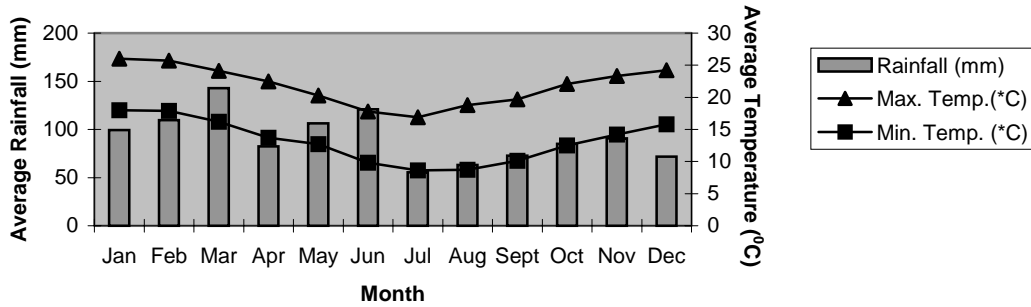

Figure 2.7 Average monthly rainfall and temperature in Wollongong from 1974 to 1997. (Data from Bureau of Meteorology Monthly Reports, 1974 – 1997. Temperature data for Wollongong was only available in this report from 1991.)

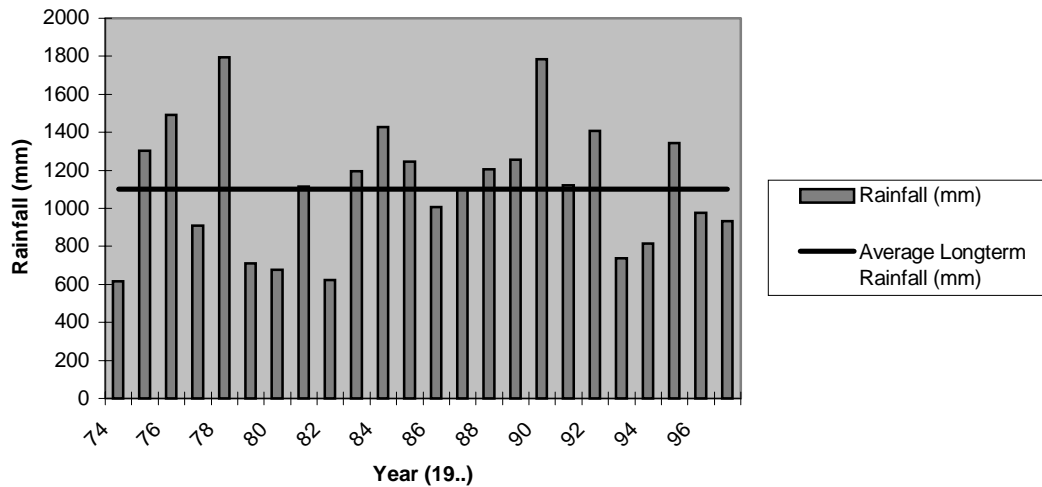

Figure 2.8 Annual rainfall recorded in Wollongong from 1974 to 1997. (Data from Bureau of Meteorology Monthly Reports, 1974–1985.)

Three types of winds are evident at Lake Illawarra. In the summer months, strong north-easterly winds are prevalent. In the winter months, strong westerly to south-westerly winds are experienced (LIA 1995). Clarke and Elliot (1984) suggest the strong winds at Lake Illawarra create wind-driven circulation that results in a well-mixed lake water body, on the most part exhibiting little variation in vertical or horizontal movement.

The Lake Illawarra Authority regularly dredges, partly to maintain lake depth and partly to remove nutrient-rich sediments, with about 30 000 m³ being extracted each year. Macroalgal harvesting has been going on since the late 1980s, with an average of 2000 tonnes dry matter removed each year (LIA 1998).

The lake is an important economic and recreational resource, with both commercial and recreational fishing activity. Yachting, water skiing and sailing attract large numbers of both local residents and tourists.

Legislative control rests with the Lake Illawarra Authority, established by the NSW Parliament in 1988, with membership from NSW government departments (Department of Land and Water Conservation – DLWC; Environmental Protection Agency – EPA; Fisheries), local government (Wollongong City Council, Shellharbour City Council) and community representatives.

Data Sources

As Lake Illawarra has been affected by local population increases and land use changes, including industrial development, a significant body of data has been collected. Only a very limited component of the data is suitable for use in LOICZ nutrient budgeting, with information being obtained from the Lake Illawarra Authority, the NSW Government (DLWC, EPA), Sydney Water Corporation, Wollongong City Council, ELCOM/Pacific Power/Integral Energy, University of Wollongong, and several consultancy reports.

A number of problems were identified with the data, including:

- inconsistent reporting of parameters measured;
- spasmodic collection of data, both temporally and spatially;
- much dry weather data, few representative data for wet weather;
- raw data not included in reports and thus not able to be scrutinised;
- methodology often not included, so comparison of data difficult;
- some data in obscure documents, often difficult to access;
- little groundwater information available;
- no coherent programs linking catchment data and lake data measurements.

Sufficient information, however, was available to compile an adequate budget as a first approximation. To determine if seasonal effects were being dramatically hidden by such an approach, wet and dry season budgets were also prepared and compared to the overall annual data. A sensitivity analysis on the influence of salinity was also completed.

Results

Water and salt budget

Average precipitation at Lake Illawarra is 1100 mm (Hean and Nanson 1985). Bureau of Meteorology data taken for Wollongong 1974 to 1997, as seen in Figure 2.8, agree with this value.

Daily evaporation is typically 1 mm in winter and 4 mm in summer (Standing Committee on Public Works 1996). Wollongong City Council and The University of Wollongong (1976) found the following figures for average monthly evaporation:

Estimated Evaporation (mm)												
J	F	M	A	M	J	J	A	S	O	N	D	Year
117	108	111	89	72	55	55	63	74	88	98	110	1040

$$V_R = -89 \times 10^6 \text{ m}^3/\text{yr}$$

$$V_{R S_R} = -2759 \times 10^6 \text{ psu m}^3 \text{ yr}^{-1}$$

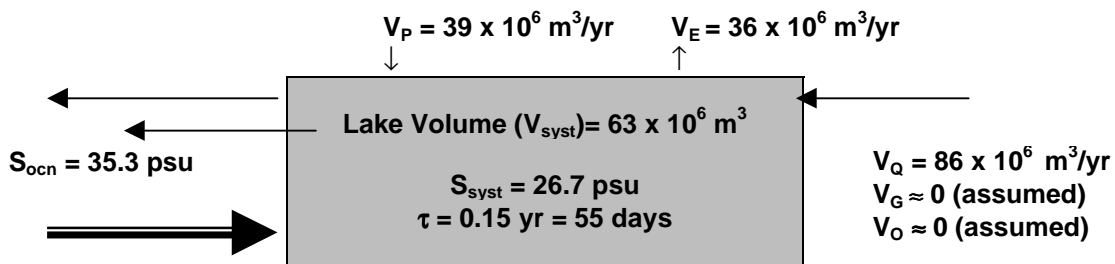

$$V_X(S_{ocn} - S_{syst}) = +2759 \times 10^6 \text{ psu m}^3 \text{ yr}^{-1}$$

$$V_X = 321 \times 10^6 \text{ m}^3 \text{ yr}^{-1}$$

Figure 2.9 Water and salt budgets, Lake Illawarra.

The above evaporation figures may be elevated as they do not allow for cloud and fog (at higher altitude), both of which reduce evaporation (WCC and UOW 1976). However, they are indicative of Lake Illawarra, considering the lake is only 25-30 cm above sea level.

LIA (1995) found runoff average (between wet and dry years) to be $86 \times 10^6 \text{ m}^3 \text{ yr}^{-1}$. This is in line with Kanamori data, where Macquarie Rivulet was gauged and found to have a runoff of $42 \times 10^6 \text{ m}^3$, and the total catchment runoff value was estimated as double this value at $80 \times 10^6 \text{ m}^3$.

Groundwater contribution is assumed as negligible; it is expected the water would surface prior to reaching the lake and thus would be included in the surface runoff (V_Q).

V_O is assumed to be zero. No other sources of water contribute to the lake system.

The Public Works Department Lake Illawarra Hydrographic Survey General Plan (1988) was used to determine if the estimated volume was appropriate, using a volume (squares-method) analysis.

Salinity in precipitation and runoff is expected to be zero or so small as to be insignificant to the salinity budget (Gordon *et al.* 1996). The salinity in Lake Illawarra can range from 6.9 to 42 psu (ELCOM 1987). The former is experienced in wet weather, where freshwater flow has a diluting effect, and the latter in dry weather, where evaporation is the major determinant of salinity concentration.

The Standing Committee on Public Works (1996) and LIA (1995) reported that the average salinity of the lake is 33 psu. From further assessment of data, we consider that this salinity value is too high to be used as an average. These figures have mostly been derived from recent reports conducted during relatively dry periods (ELCOM 1984, Collie 1991, Simeoni *et al.* 1995 and Ferguson *et al.* 1995). Other studies which have reported much lower levels of salinity in the Lake Illawarra system were generally conducted over a more 'normal' (i.e., ≥ 1100 mm) rainfall conditions, or over a longer time and taking more climatic cycles into account: Anderson and Storey (1981) recorded an average salinity of 28.6 (24/3/76 to 12/8/76); Kanamori (1976) recorded an average salinity of 24.7 (7/4/72 to 21/1/74); and Brown (1968) recorded salinity near Tallawarra Power Station about weekly (2/1/57 to 17/8/65), with an average value of 26.7 psu.

Brown's (1968) average has been used in this budget as it covers the most extensive time period, although the values at the former Tallawarra Power Station site may not be fully representative of the salinity in Lake Illawarra in general.

Ocean Salinity = 35.3 psu (ERM McCotter & Associates 1994)

$$\text{Residual salt flux } (S_R) = \frac{S_{\text{ocean}} + S_{\text{sys}}}{2} = 31 \text{ psu}$$

Residual flow is negative, indicating flow from the system. Under these conditions, mixing (V_x) is likely to transport salt into the system.

$$\text{Exchange Time } (\tau) = \frac{V_{\text{sys}}}{V_x + |V_r|} = 56 \text{ days}$$

This value compares with estimates by the Lake Illawarra Authority where from an exchange rate of about 1 million $\text{m}^3 \text{d}^{-1}$, an exchange time of 63 days was calculated (G. Clarke, personal communication 1997).

Dissolved inorganic phosphorus budget

ELCOM (1984 and 1987) data were two consistent data sets for system phosphorus concentration; the average of these has been used in the model (1.9 mmol m^{-3}).

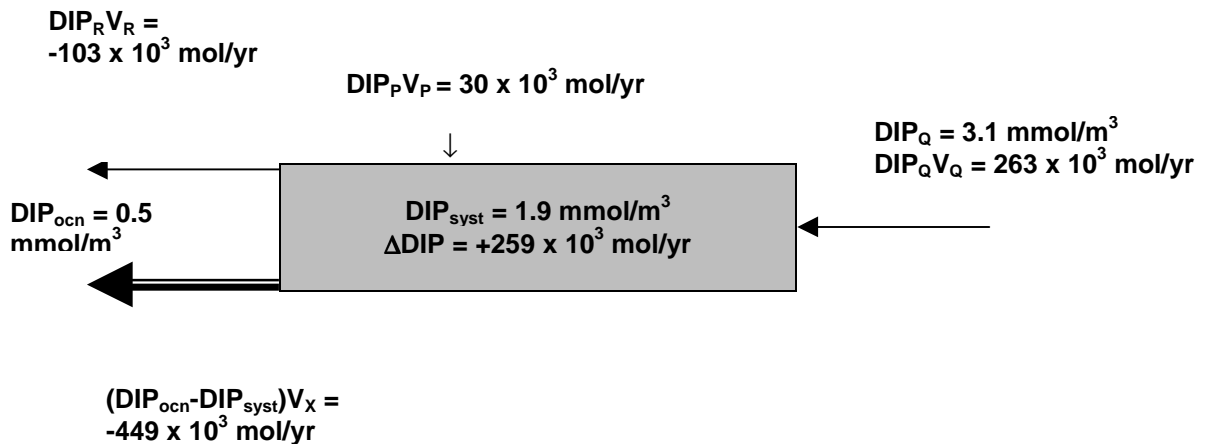

Figure 2.10 DIP budget, Lake Illawarra.

Average precipitation contains 0.8 mmol m^{-3} total phosphorus, of which 95% is as DIP (LIA 1995).

Total Phosphorus Inflow = $263 \times 10^3 \text{ mol yr}^{-1}$ (LIA 1995). This approximates an inflow P concentration of 3.1 mmol m^{-3} . Phosphorus in the ocean is approximately 0.8 mmol m^{-3} (LIA 1995) of which only 60% is available as orthophosphate, *viz.*, 0.48 mmol m^{-3} .

Outward transport occurs via both residual flow and mixing, in excess of the estimated inflow contributed by rainfall and catchment runoff. Thus, there appears to be an internal source of DIP contributing approximately $260 \times 10^3 \text{ mol yr}^{-1}$ ($\sim 0.01 \text{ mol m}^{-2} \text{ yr}^{-1}$). Davey (1994) and Woodward (1986) suggested this source is sediments recycling processes. Others suggest that recycling contributes $>80\%$ of the system phosphorus during non-event periods (Sydney Water 1998).

Nitrogen budget

Information on nitrogen in the lake system is not easily accessible because of the both array of nitrogen species and analytical methods applied to historical measurements, including:

- Total Nitrogen
- Total Kjeldahl Nitrogen
- Total Uncombined Ammonium
- Nitrogen oxides *i.e.*, nitrate and nitrite.

For the purposes of this budget ELCOM (1984) data were utilised. $DIN_{\text{sys}} = 2.4 \text{ mmol m}^{-3}$.

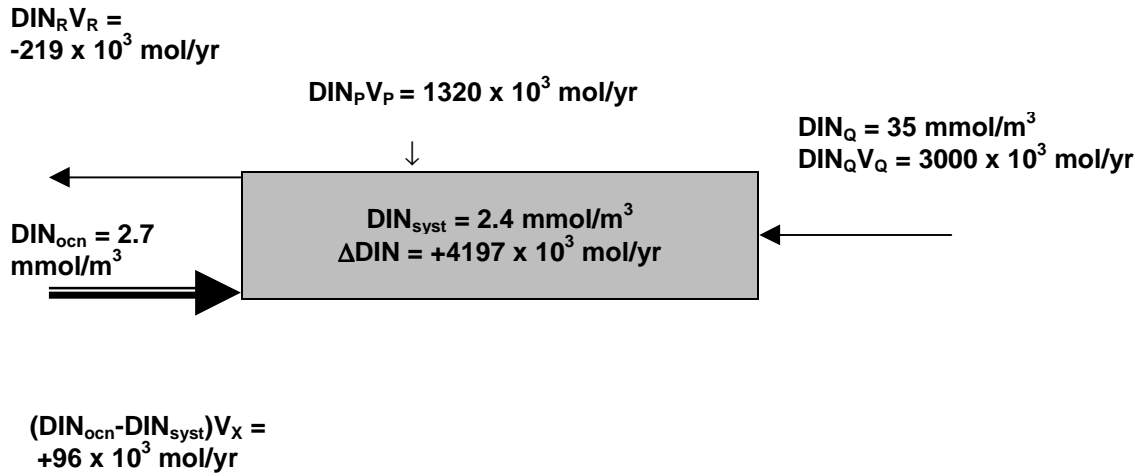

Figure 2.11 DIN budget, Lake Illawarra.

Average precipitation contains about 36 mmol m^{-3} nitrogen, of which 95% is available as DIN (LIA 1995) thus $\sim 34 \text{ mmol m}^{-3}$.

Total Nitrogen Inflow = 10^6 mol yr^{-1} of which DIN is estimated to contribute 30% (LIA 1995). This equals a DIN delivery of approximately $3 \times 10^6 \text{ mol yr}^{-1}$, and as catchment inflow is averaged at $86 \times 10^6 \text{ m}^3 \text{ yr}^{-1}$, concentration is approximately $35 \times 10^{-3} \text{ mol m}^{-3}$.

Total nitrogen in the ocean is reported as approximately 18 mmol m^{-3} (LIA 1995), of which only 15% is DIN, i.e., $\sim 2.7 \text{ mmol m}^{-3}$. Therefore, the outward DIN flux is at least an order of magnitude lower than the influx of nitrogen from the catchment.

Consequently, there appears to be a sink for DIN in this system and fits the previous report of Lake Illawarra being a nitrogen limited system (LIA 1995). However, flux measurements are needed to consolidate these first estimates.

Stoichiometric Calculations According to the LOICZ Guidelines

Carbon:Phosphorus Stoichiometry

$$\begin{aligned}
 \Delta DIC &= \Delta DIP \times (C:P)_{\text{part}} \\
 &= 259 \times 10^3 \text{ (mol yr}^{-1}) \times 106 \quad (\text{assuming plankton dominance} \\
 &\quad \text{of primary production}) \\
 &= 2.75 \times 10^7 \text{ mol C yr}^{-1}
 \end{aligned}$$

Net Ecosystem Metabolism

$$\begin{aligned}
 (p-r) &= -2.75 \times 10^7 \text{ mol yr}^{-1} = -0.8 \text{ mol m}^{-2} \text{ yr}^{-1} \\
 &= -2.2 \text{ mmol m}^{-2} \text{ d}^{-1}
 \end{aligned}$$

The system appears to be net heterotrophic, according to the LOICZ approach.

Net primary production in Lake Illawarra has been estimated at about $101 \text{ mol m}^{-2} \text{ d}^{-1}$ (Ian Webster and Phillip Ford, CSIRO, personal communication 1998), which suggests that (*p-r*) is about 2% of the primary production and the P/R ratio is about 0.98.

Nitrogen:Phosphorus Stoichiometry

$$\begin{aligned}
 (\text{nfix-denit}) &= \Delta\text{DIN}_{\text{obs}} - \Delta\text{DIN}_{\text{exp}} = \Delta\text{DIN} - \Delta\text{DIP} \times (\text{N:P})_{\text{part}} \\
 &= (-4197 \times 10^3) - (259 \times 10^3) \times 16 \\
 &= -8341 \times 10^3 \text{ mol yr}^{-1} \\
 &= -0.24 \text{ mol m}^{-2} \text{ yr}^{-1} = -0.7 \text{ mmol m}^{-2} \text{ d}^{-1}.
 \end{aligned}$$

This rate of net denitrification compares with reports from similar systems (Seitzinger, 1988). These estimates assume that plankton dominate primary production. In Lake Illawarra there is significant productivity both of seagrasses (*Zostera* and *Ruppia*) and macroalgae. These macrophytes will contribute to a slightly different C:N:P ratio than phytoplankton for estimating the organic material, but these changes have been ignored in this analysis.

Sensitivity Analyses

An attempt was made to estimate budgets for the Lake in two seasons, one wet and one dry, each lasting for 6 months. In dry weather, the residence time of freshwater more than doubles and the exchange time is reduced by 70%. This leads to a ΔDIP of $+645 \times 10^3 \text{ mol yr}^{-1}$ and a ΔDIN of $-2600 \times 10^3 \text{ mol yr}^{-1}$. Under wet weather conditions, the freshwater residence time is reduced and the exchange time is increased, whereby ΔDIP is calculated to be $-12 \times 10^3 \text{ mol yr}^{-1}$ and ΔDIN to be $-4612 \times 10^3 \text{ mol yr}^{-1}$. The combination of these seasonal budgets yields a similar outcome as that estimated above for an annual budget.

It should be noted that there is some difficulty in determining an appropriate mean salinity for this system and that the calculated residence times and nonconservative fluxes are, as expected, sensitive to the salinity values chosen.

Conclusion

LOICZ budgets have been developed for Lake Illawarra and the results obtained from carrying out the modelling exercise are in line with observations on the Lake. The Lake would appear to be losing nitrogen by denitrification, and is a system that is a net producer of DIC by respiration.

2.4 GIPPSLAND LAKES, VICTORIA

Ian T. Webster and Phillip W. Ford

Site Area Description

The Gippsland lakes (Site No. 24.; 147.00E, 38.00S) are three interconnected coastal lakes in Victoria, Australia (Figure 2.14; see Figure 1.1). Their area (400 km²) and large catchment (20 000 km²) places them amongst the largest Australian coastal lake systems. Their most important physical characteristics are set out in Table 2.12 and their geomorphological and geological setting is detailed in Bird (1978).

Figure 2.12 The Gippsland Lakes region of Victoria.

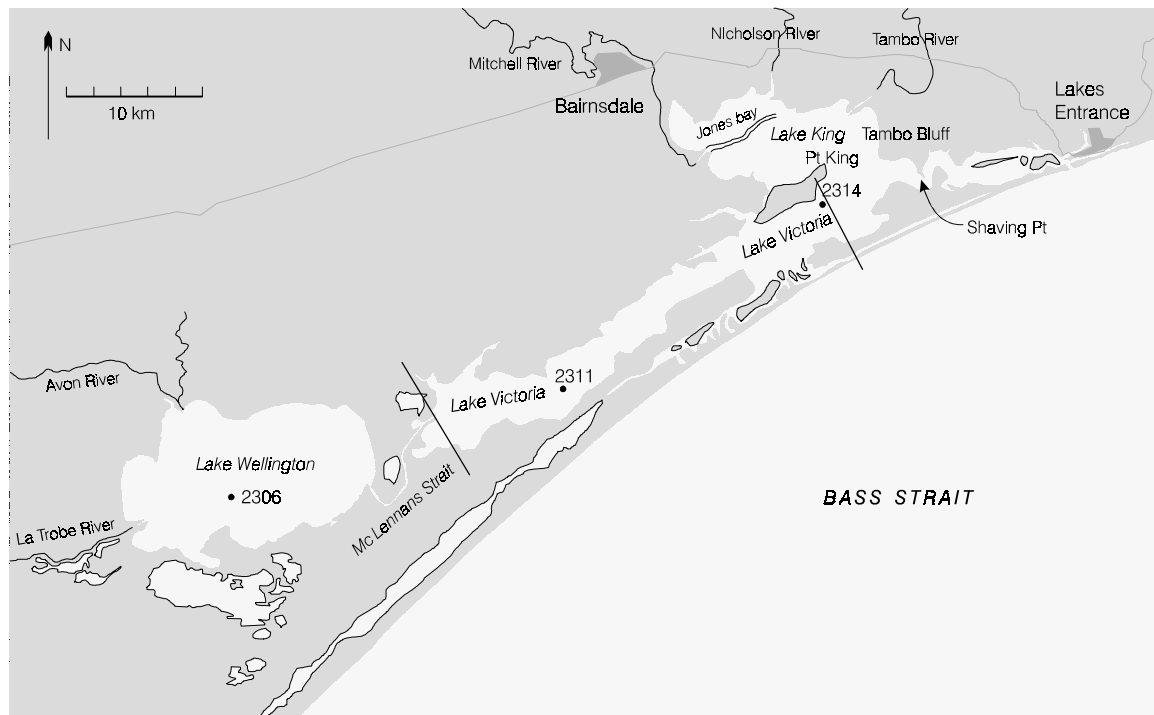

Table 2.12 Physical dimensions of the major Gippsland lakes. (Data from Bek and Bruton 1979.)

Compartment	Mean Length (km)	Mean Width (km)	Surface area (km ²)	Mean depth (m)	Max. Depth (m)	Volume (10 ⁶ m ³)
Lake Wellington	17.8	9.7	148	2.6	6	385
McLennans Strait	9.7	0.2	2	5	8	10
Lake Victoria	27.4	3.2	75	4.8	9	343
Lake King	12.9	6.5	98	5.4	10	524

Originally the lakes were a series of brackish coastal lagoons only intermittently connected to the sea, but in 1889 a permanent entrance to the sea was built at Lakes Entrance. As a consequence, the mean water levels in the lakes were lowered and the

water level range decreased; salinity increased in all lakes. The salinity effects are most pronounced in summer as the average annual evaporation (1200 mm) exceeds the precipitation (660 mm) (Robinson 1995). Rainfall and river inflows are greatest in winter.

The lakes are an important recreational resource and also encompass internationally recognised migratory bird sanctuaries, wetlands and national parks. The ecosystem is still adapting to the changes associated with an estuarine environment but is perceived to be degrading with a loss of submerged macrophytes (around the fringes of Lake Wellington), blooms of *Nodularia spumigena* increasing water turbidity, and declining catches in both the commercial and recreational fisheries, all contributing to a public perception of a degraded ecosystem.

The catchment has undergone major changes. Originally heavily forested, the coastal plains and lower slopes have been largely cleared for agriculture including irrigated agriculture and grazing. The flows in the major rivers entering Lake Wellington (Latrobe, Macallister and Thomson rivers) are controlled by storages. The rivers flowing into Lake King are unregulated. Extensive planting and harvesting of native and plantation timber continues in the catchment. A major brown coal-fired power generation industry, and a large paper mill are located on the Latrobe River as are the major towns of the region (total population 130 000). For about 50 years, cooling water, mine water and other effluents plus treated sewage effluent were discharged to the Latrobe River. This has now been diverted from the river. Goldmining in the 19th century has left numerous actively-eroding scars on the landscape and is thought to be the source of high mercury concentrations in the lake sediments.

There have been numerous investigations into various aspects of the behaviour of the lakes' ecosystems, often triggered by nuisance algal blooms. A recent review (Harris *et al.* 1998) provides an entry point to this earlier work. There has not been, however, a well-structured long-term monitoring program of nutrient inputs to the lakes, or an integrated investigation of the ecodynamics of the system as a whole. The calculations reported here are based on data supplied by Mr. David Robinson (EPA Victoria) and his help is gratefully acknowledged.

Water and Salt Budgets

Figure 2.15 gives the water and salt budgets for the combined Wellington-Victoria system. The calculations for the years 1988-1990 (July to July) assumed an inflow salinity of zero psu. Runoff is based on weekly measurements of the flow of all the major rivers. Groundwater flow is assumed to be zero. Rainfall is estimated to be $88 \times 10^6 \text{ m}^3 \text{ year}^{-1}$ and evaporation $172 \times 10^6 \text{ m}^3 \text{ year}^{-1}$. The average water residence times were: 84 days (1988-89) and 92 days (1989-90). The exchange time of Lake Victoria alone was about 45 days in 1988-89 and 49 days in 1989-90. Lake Wellington is shallow and is treated as well-mixed. Lake Victoria, on the other hand, is stratified and there is a two-way salt exchange between Lake Victoria and both Lake Wellington and Lake King.

WATER BUDGET ($10^6 \text{ m}^3/\text{yr}$)

July 1988 - July 1989
May 1989 - May 1990

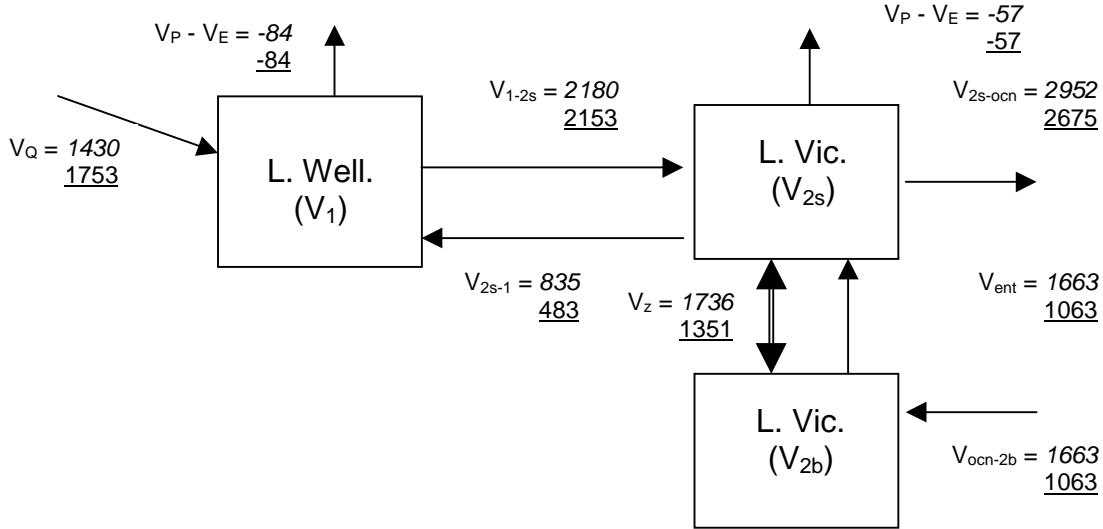

SALT BUDGET (10^9 kg/yr)

July 1988 - July 1989
May 1989 - May 1990

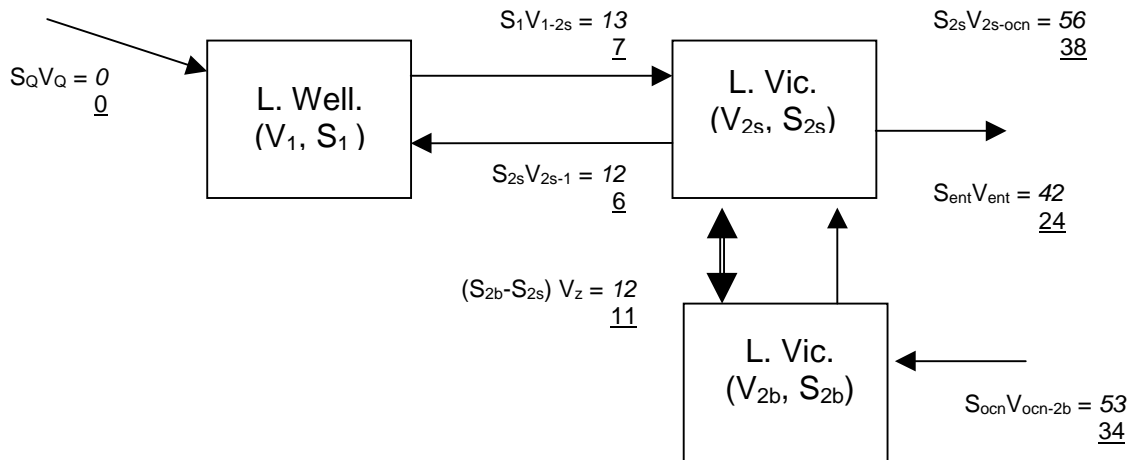

Figure 2.13 Water and salt budgets for July 1988 to May 1990, Lakes Wellington and Victoria.

DIP BUDGET (10^6 mol/yr)

July 1988 - July 1989
May 1989 - May 1990

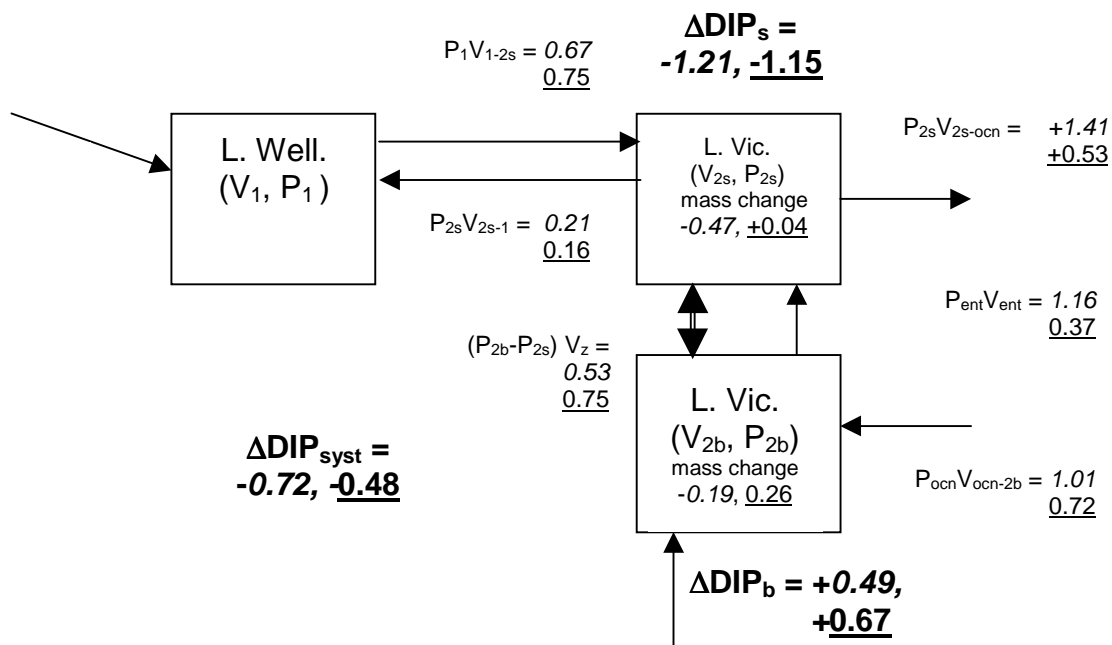

Figure 2.14 DIP budget, Lake Victoria. (DIP concentration of water entering Lake Wellington is not known, although the DIP concentration of water in the lake is known. Therefore the water and salt budgets (Figure 2.13) are used to constrain the exchanging water flow between Lakes Wellington and Victoria. Moreover the changing mass of DIP in Lake Victoria is too large to be treated as 0, so this change is included in the budget.)

DIN BUDGET (10^6 mol/yr)

July 1988 - July 1989

May 1989 - May 1990

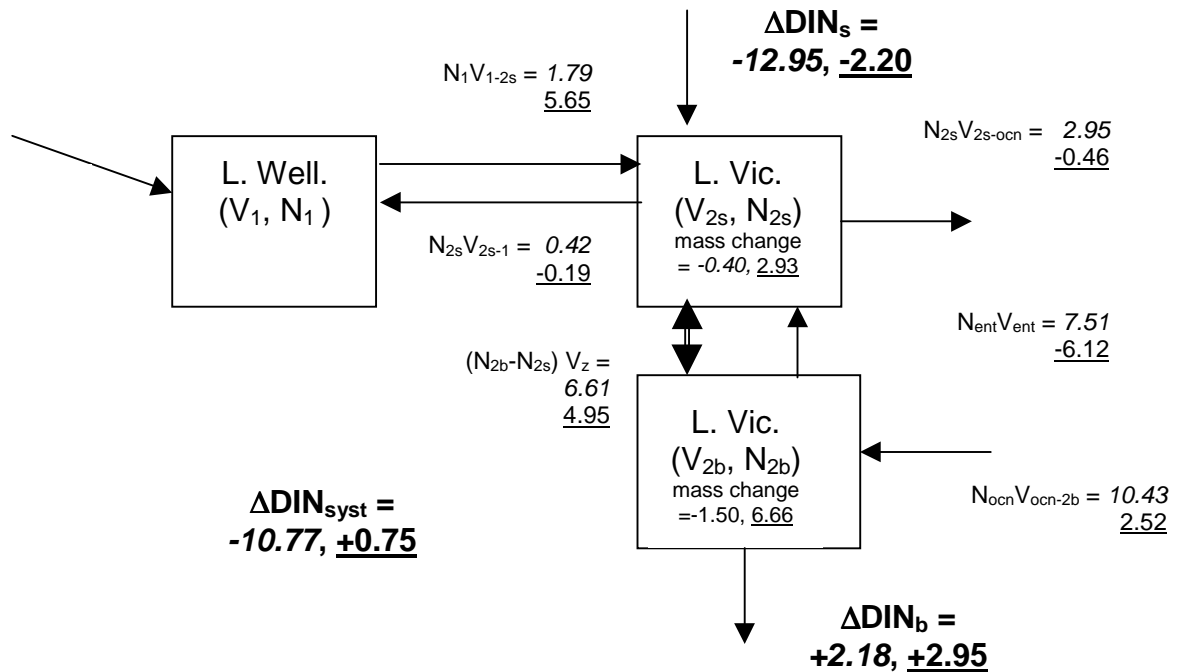

Figure 2.15 DIN budget, Lake Victoria. (DIN concentration of water entering Lake Wellington is not known, although the DIN concentration of water in the lake is known. Therefore the water and salt budgets (Figure 2.13) are used to constrain the exchanging water flow between Lakes Wellington and Victoria. Moreover the changing mass of DIN in Lake Victoria is too large to be treated as 0, so this change is included in the budget.)

Budgets DIP and DIN

DIP Balance

Figure 2.14 displays the P budget for Lake Victoria. In the budgetary analysis, the surface and bottom layers are estimated separately; the surface and bottom data are then combined to establish a whole-lake budget. The calculation uses the concentrations of DIP, DIN and salinity measured at stations 2306, 2311 and 2314 (Figure 2.12). The composition of Lake Wellington inflow water is not known, although the composition of Lake Wellington water is known. Therefore Lake Wellington water is treated as the source water for Victoria. Lake Victoria is a net sink for DIP. Note that the surface layer of the lake is a net sink, while the deep layer is a net source.

DIN Balance

A similar balance is established for DIN in Lake Victoria, with Lake Wellington as the source water (Figure 2.15). Lake Victoria was a sink in 1988-89 and a source in 1989-90. Further, the surface layer was a net sink while the deep layer was a net source in both years.

Stoichiometric Calculations of Aspects of Net System Metabolism

Nitrogen fixation-denitrification (*nfix-denit*) for Lake Victoria was calculated from the difference between the observed and expected Δ DIN for the whole system (surface and bottom), where the expected value is given by Δ DIP x N:P ratio of the organic matter which is reacting (assumed to be phytoplankton with a Redfield N:P ratio of 16:1).

Year 1:

$$\begin{aligned}(\text{nfix-denit}) &= -10.77 \times 10^6 - 16 (-0.72 \times 10^6) = +0.75 \times 10^6 \text{ mol yr}^{-1} \\ &= +0.02 \text{ mmol m}^{-2} \text{ d}^{-1}.\end{aligned}$$

Year 2:

$$\begin{aligned}(\text{nfix-denit}) &= 0.75 \times 10^6 - 16 (-0.48 \times 10^6) = 6.93 \times 10^6 \text{ yr}^{-1} \\ &= +0.19 \text{ mmol m}^{-2} \text{ d}^{-1}.\end{aligned}$$

These calculations suggest that in both years the system was a slight net nitrogen-fixing system.

Δ DIP was also used to calculate the net ecosystem metabolism ($NEM = [p-r]$), as shown below, with the assumption that the reacting organic matter has an approximate Redfield C:P ratio of 106:1.

Year 1:

$$\begin{aligned}(p-r) &= -106 (-0.72 \times 10^6) = +76 \times 10^6 \text{ mol C yr}^{-1} \\ &= +2.1 \text{ mmol C m}^{-2} \text{ d}^{-1}.\end{aligned}$$

Year 2:

$$(p-r) = -106 (-0.48 \times 10^6) = +51 \times 10^6 \text{ mol C yr}^{-1}$$

$$= +1.4 \text{ mmol C m}^{-2} \text{ d}^{-1}.$$

The system thus appears to be mildly autotrophic.

Estimates of N and P Fluxes in a Stratified Estuary with Time-Varying Inflows

The system is not necessarily well characterised as being a steady-state system.

Therefore a non-steady state analysis was also undertaken. Using the weekly inflow data and interpolating between the fortnightly water column concentration data, daily values for the fluxes of DIN and DIP between Lake Victoria and Lakes Wellington and King were calculated as well as the net internal fluxes. The data were smoothed with a filter that had a cut-off period (half amplitude) of 90 days. The time trend (non-steady state behaviour) of the loading, internal storage, and calculated net fluxes are shown in Figures 2.16 and 2.17. Figures 2.18 and 2.19 illustrate the stoichiometric calculations based on these data.

The important point to note in these analyses is that, while the previous calculations treat the system as if it were at steady state, there is considerable variation in the load and internal nonconservative fluxes for the system. In this case, the mean values obtained by the steady state analysis do not differ greatly from the non-steady state mean values, but the temporal variation is an important characteristic of the system.

Detailed budgetary analysis should take this temporal variability into account (see Webster, Parslow and Smith, Appendix III, for a further analysis of this problem).

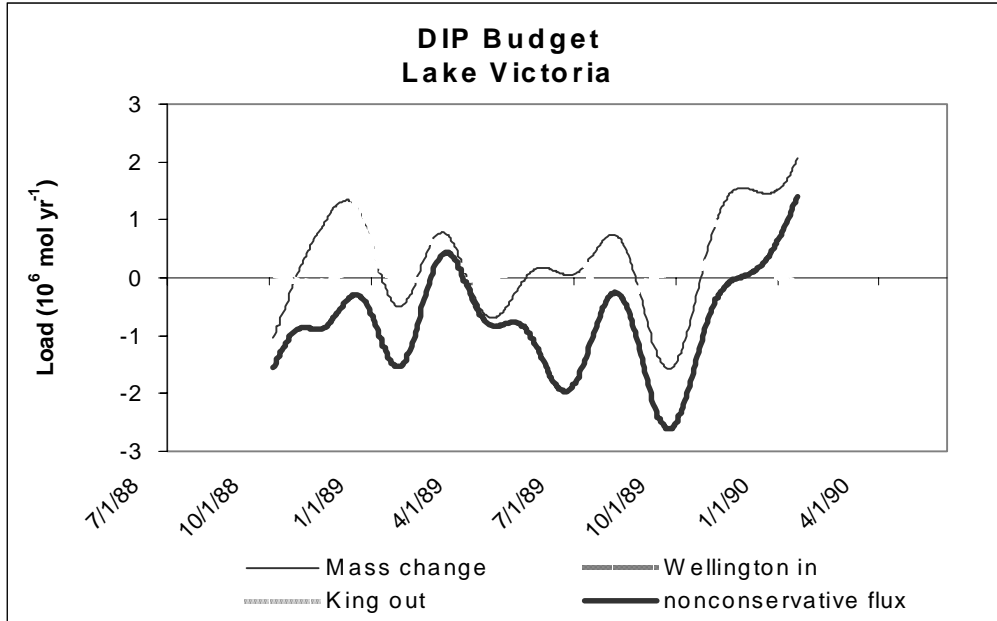

Figure 2.16 Temporal variability (smoothed) in mass of DIP in Lake Victoria, input to it and output from it. (These terms lead to an estimate of the temporal variability in ΔDIP within this system.)

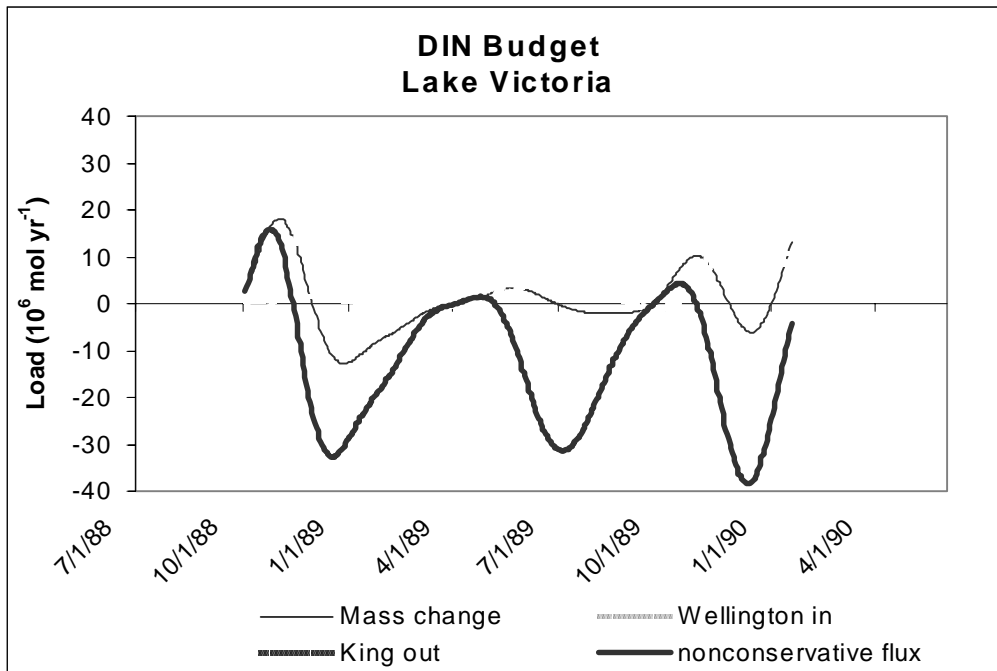

Figure 2.17 Temporal variability (smoothed) in mass of DIN in Lake Victoria, input to it and output from it. (These terms lead to an estimate of the temporal variability in ΔDIN within this system.)

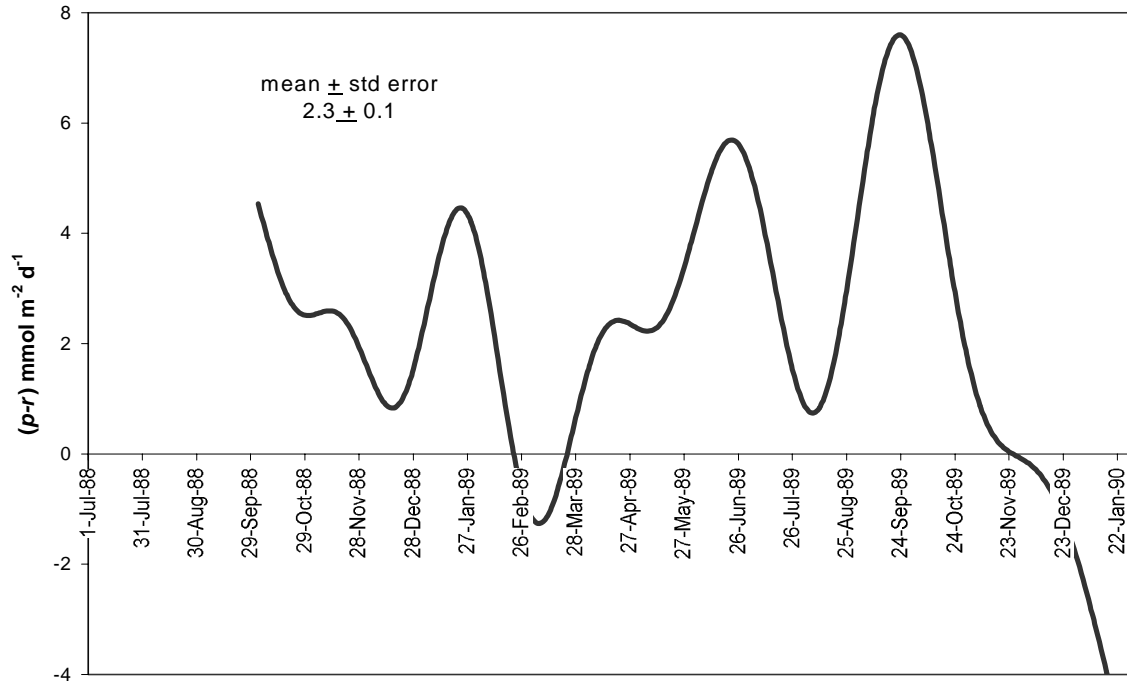

Figure 2.18 Time-varying $(p-r)$ for Lake Victoria. (Calculated from Figures 2.16 and 2.17 and scaled per unit area.)

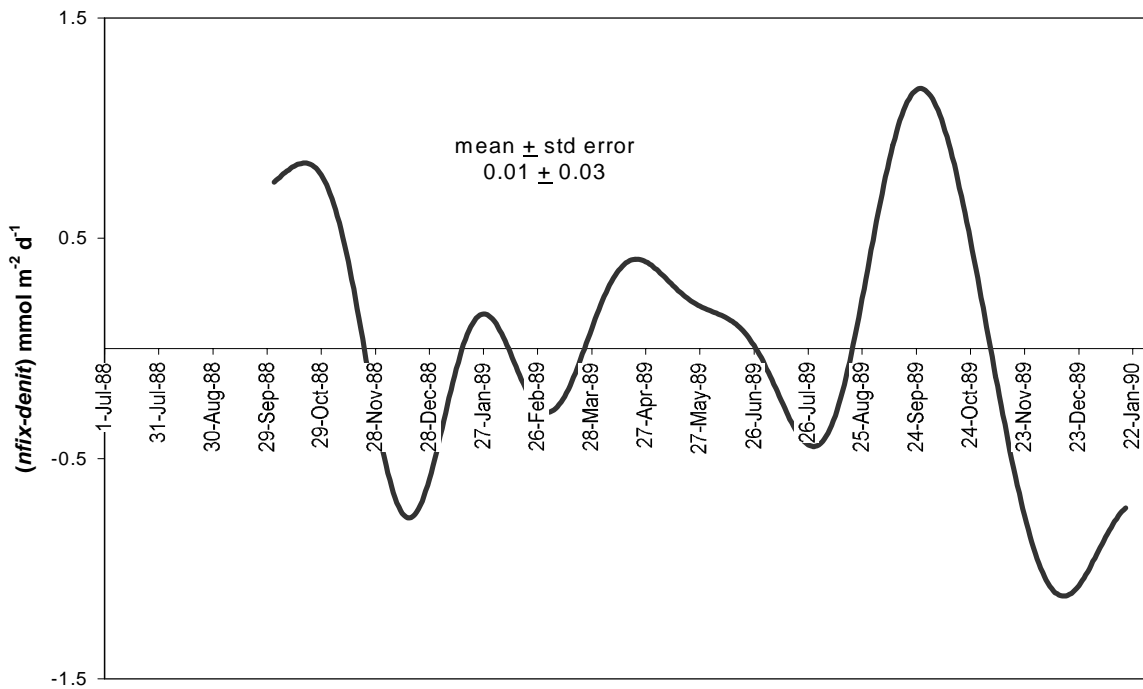

Figure 2.19 Time-varying $(nfix-dentit)$ for Lake Victoria. (Calculated from Figures 2.16 and 2.17 and scaled per unit area.)

2.5 NITROGEN AND PHOSPHORUS BUDGETS FOR PORT PHILLIP BAY

John Parslow

Study Area Description

Port Phillip Bay (Site No. 25.; 145.00E, 38.00S) is a large (1 900 km²), shallow coastal embayment in south-eastern Australia (Figure 2.22; see Figure 1.1). The catchment of 9790 km² includes the city of Melbourne, with a population of 3 million people. The Bay was the subject of a major environmental study, the Port Phillip Bay Environmental Study (PPBES), conducted from 1992 to 1996 (Harris *et al.* 1996). This study included extensive spatial surveys of water column and sediment nutrient and chlorophyll concentrations, and measurements of primary production, grazing and sediment-water fluxes. Annual nitrogen and phosphorus budgets and a process-based dynamic model of nitrogen cycling through planktonic and benthic systems, were developed as part of the Study (Harris *et al.* 1996, Murray and Parslow 1997). This paper revisits those budgets using LOICZ Biogeochemical Modelling Guidelines.

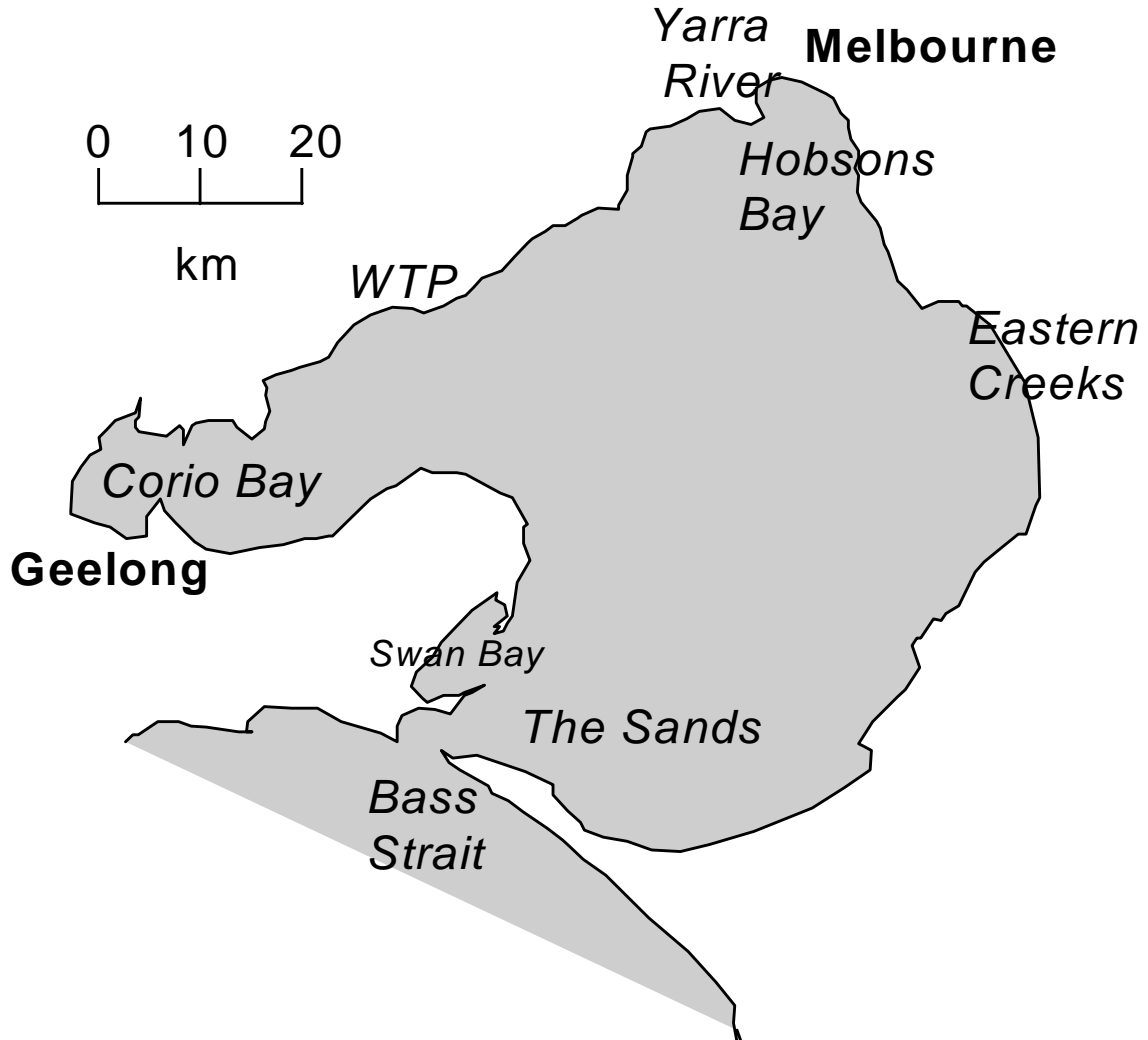

Figure 2.20 Port Phillip Bay, and regions of principal nutrient sources.

Freshwater and salt balance, and flushing rates

Physically, the Bay resembles a broad shallow basin, with a maximum depth of 25 m, mean depth of 13 m, and volume of about $25 \times 10^9 \text{ m}^3$. The Bay exchanges with coastal waters (Bass Strait) through a very restricted entrance (the Heads), and across a broad shallow flood tidal delta (the Sands). As part of the PPBES, estimates of flushing rate were obtained in three ways (Walker 1997):

- high resolution measurements of salinity and velocity across the Sands using ADCP and surface radar;
- budgets of salt and freshwater for the entire Bay;
- analysis of a high-resolution 3-D hydrodynamic model and derived transport model.

All three methods agree that the flushing time of the Bay is very long, of order one year. The tidal prism would be sufficient to flush the Bay in about 14 days if tidal exchange were 100% efficient. Tidal flushing is very inefficient because the tidal excursion along the major channels through the Sands is less than the channel length, so that water moves back and forth along the channels without penetrating into the central basin. The instantaneous estimate of flushing time from the high-resolution surveys conducted was 340 days, with an uncertainty of somewhat over 40 days (Walker 1997).

Over the 5 years 1990 to 1994, evaporation was the dominant term in the freshwater budget ($86 \text{ m}^3 \text{ s}^{-1}$), and almost exactly balanced the estimates of combined surface runoff ($41 \text{ m}^3 \text{ s}^{-1}$) and rainfall ($42 \text{ m}^3 \text{ s}^{-1}$) (Harris *et al.* 1996). Uncertainties in the individual estimates means that the net freshwater flux is very uncertain, and cannot be used to compute reliable estimates of flushing rates. Walker (1997) calibrated a transport model so as to reproduce the observed temporal and spatial pattern of salinity in the Bay, and found that this was only possible if evaporation was reduced by 30%, or rainfall estimates increased by 60%. This implies a net freshwater influx $V_R = 30 \text{ m}^3 \text{ s}^{-1}$, or $9.5 \times 10^8 \text{ m}^3 \text{ yr}^{-1}$. The mean flushing time for the transport model is about 290 days. The model predicts that effective flushing times vary within the interior of the Bay from about 270 days in the Bay centre adjacent to the Sands to about 315 days in Corio Bay in the far west.

Loads

Loads into the Bay have been estimated using a combination of catchment models and direct estimates (Table 2.14). About half of Melbourne's sewage is treated at the Western Treatment Plant (WTP), which discharges into Port Phillip Bay on the western side (Figure 2.22). The associated nutrient loads have been calculated from weekly measurements of concentration and flow. Loads from the major catchments (Yarra River and Patterson-Mordialloc) have been estimated by fitting empirical catchment models to daily flow time-series and intermittent concentration measurements (Sokolov 1996).

Loads from a large number of minor streams and drains are more uncertain, but represent a small fraction (5% or less) of total loads. Atmospheric nitrogen loads have been estimated (via modelling) to be about $71 \times 10^6 \text{ mol N yr}^{-1}$, with an uncertainty of about 50%. Estimates of annual loads of ammonium, nitrate, DIN, DIP, organic N, organic P and silicate for the study field period (1993-95) are given in Table 2.14. Silicate was not

routinely measured in catchment monitoring programs, and silicate load estimates are based on historical data and considered more uncertain.

Table 2.14 Nutrient loads into Port Phillip Bay in 1993 to 1995 (10^6 mol yr⁻¹).

	Western Treatment Plant	Yarra River	Patterson-Mordialloc	Minor Streams and Drains	Atmosphere	TOTAL
NH ₄	154	10	9	3	64	240
NO ₃	32	28	20	3	7	89
DIN	186	38	29	5	71	329
DIP	34	11	5	4	0	53
ON	63	61	38	5	0	167
OP	6	3	2	1	0	12
SiO ₄	44	47	59	0	0	150

Water Column Concentrations.

During the PPBES field program (1993-95), nutrient concentrations were measured underway along monthly transects designed to sample the spatial gradients within the Bay (Longmore *et al.* 1996). Depth profiles were also measured at a series of 11 stations distributed around the Bay. Except near major streams during high-flow events, the water column was almost always vertically well-mixed.

Table 2.15 Mean concentrations from PPBES spatial surveys (mmol m⁻³).

	Bay-wide Average	Bay Centre	Heads (Flood)
NH ₄	0.64	0.51	0.38
NO ₃	0.31	0.13	0.23
DIN	0.95	0.64	0.61
DIP	2.05	1.76	0.24
DON	9.46	8.91	6.12
PTN	1.99	1.59	1.26
ON	11.45	10.50	7.38
TN	12.40	11.14	7.99
DOP	0.21	0.17	0.12
PTP	0.16	0.12	0.09
OP	0.37	0.29	0.21
TP	2.42	2.05	0.45
DOC	1.71	1.56	0.98
POC	0.13	0.09	0.09
OC	1.84	1.65	1.07
SiO ₄	4.81	5.12	1.03

Given that the flushing time is long compared with the internal mixing time, we have computed budgets for the Bay as a single compartment, averaged over the 1993-95 field study. However, there are strong gradients within the Bay away from the major point sources, especially in the case of DIN, which is elevated near WTP and the mouth of the Yarra, but very low in the Bay centre. One could estimate export fluxes using the Bay-wide average concentrations and a mean flushing time, but for tracers such as DIN which do not behave conservatively this may over-estimate export, which occurs through exchange between the Bay centre and Bass Strait across the Sands. Instead, we have used Bay centre concentrations and a flushing rate corresponding to the Bay centre. Table 2.15 shows both Bay-wide average concentrations and Bay centre concentrations.

The Bass Strait (boundary) concentration has been estimated by averaging measurements at a station located at the Heads and occupied on flood tide. Mean annual concentration values for this station are given in Table 2.15.

Table 2.16 Loads, export fluxes and net sources of nutrients in Port Phillip Bay. (Net sources are given as both Bay-wide annual fluxes, and average daily fluxes per unit area.)

	Loads (10^6 mol yr ⁻¹)	Export (10^6 mol yr ⁻¹)	Δ (10^6 mol yr ⁻¹)	Δ (mmol m ⁻² d ⁻¹)
NH ₄	211	5	-207	-0.298
NO ₃	118	-3	-121	-0.174
DIN	329	2	-327	-0.472
DON		95		
PTN		12		
ON	167	107	-60	-0.087
TN	496	108	-387	-0.559
DIP	53	48	-5	-0.007
DOP		2		
PTP		1		
OP	12	3	-9	-0.013
TP	65	52	-14	-0.020
DOC		19		
POC		0		
OC		20		
SiO ₄	150	132	-18	-0.027

N, P and Si Budgets.

The net export fluxes from the Bay to Bass Strait are presented in Table 2.16. These fluxes were calculated using LOICZ Guidelines (Gordon *et al.* 1996) as $V_R \times (C_1 + C_2)/2 + V_X \times (C_1 - C_2)$, where C_1 is the Bay centre concentration, C_2 is the Heads flood concentration and $V_X = 25 \times 10^9 \times 365/270$ m³ yr⁻¹. Table 2.16 also presents estimates of net sources (Δ) for the Bay, for those nutrients for which load estimates are available.

Because dissolved and particulate organic forms were not distinguished in inputs, it is not possible to estimate net sources of these forms separately.

Because DIN concentrations are so low in Port Phillip Bay, DIN export is negligible compared with loads. The Bay is a net sink for DIN, and the size of this sink is quite insensitive to flushing rate. The Bay exports organic N, primarily as DON, amounting to 64% of the load of organic N. Refractory DON from the catchment could account for most of this DON export. Of the total N (TN) load of $496 \times 10^6 \text{ mol yr}^{-1}$, 22% is exported, and 78% is lost to internal sinks.

By contrast with DIN, most of the DIP load to Port Phillip Bay is exported as DIP. It has long been recognised that Port Phillip Bay is N-limited, and that DIP is present in excess with respect to DIN. It is distributed within the Bay like a conservative tracer. There is a net sink of about 10% of the DIP load, and this estimate is quite sensitive to flushing rate. The data also indicate an additional sink of organic P amounting to about 75% of the organic P load. Of the total P (TP) load of $65 \times 10^6 \text{ mol yr}^{-1}$, about 78% is exported, and 22% is lost to internal sinks.

The estimated sink of silicate is 12% of the load, but given the uncertainties in load estimates, export and load can only be said to be in reasonable balance.

Stoichiometry and Internal Sinks.

The internal sink of nitrogen may be attributed either to denitrification, or to burial of organic matter. Phosphorus may be lost through burial of either organic or adsorbed inorganic P. The LOICZ Guidelines assume that burial of adsorbed inorganic P is negligible in coastal waters, and that the DIP sink represents a net production of organic matter. Sediment and water column studies in the Bay suggest that organic matter production is dominated by phytoplankton at close to Redfield ratios. The DIP sink then represents a net community production ($p-r$) of $-0.7 \text{ mmol C m}^{-2} \text{ d}^{-1}$. By comparison, primary production measurements (Harris *et al.* 1996) suggest that net primary production averages over $20 \text{ mmol C m}^{-2} \text{ d}^{-1}$, so that $p:r$ is less than 1.04. According to the LOICZ interpretation, the internal sink of TP is all due to burial of organic P. At Redfield ratios, this represents a burial rate of $2.12 \text{ mmol C m}^{-2} \text{ d}^{-1}$ (Table 2.17).

According to the LOICZ interpretation, nitrogen fixation-denitrification ($nfix-denit$) is given by: $\Delta \text{DIN}_{\text{obs}} - 16 \times \Delta \text{DIP} = -254 \times 10^6 \text{ mol yr}^{-1}$, or $-0.37 \text{ mmol m}^{-2} \text{ d}^{-1}$. Net denitrification then accounts for 77% of the DIN load, and 51% of the TN load. The organic N export represents 22% of the TN load, and 27% of the TN load ($133 \times 10^6 \text{ mol yr}^{-1}$ or $0.19 \text{ mmol N m}^{-2} \text{ d}^{-1}$) is buried as organic N (Table 2.17).

Measurements of sediment composition and sediment-water fluxes in Port Phillip Bay suggest a rather different interpretation of the N and P sinks. Benthic chamber measurements showed very high denitrification efficiencies, averaging 70% of the benthic remineralisation (Nicholson *et al.* 1996). The chamber measurements also showed significant adsorption of DIP to sediments (i.e., the flux of DIP out of sediments was lower than predicted from oxygen and carbon fluxes using Redfield stoichiometry).

On average, DIP adsorption in sediments represented about 40% of the DIP expected from benthic remineralisation. This implies a DIP adsorption sink amounting to about 0.036 times the denitrification sink (molar ratio).

Over most of the Bay, particulate C, N and P concentrations in sediments showed little variation with depth over the top 20 cm, and N:P ratios were consistently about 6.3 (by moles). This is much lower than Redfield, and strongly suggests burial of inorganic P, since refractory organic matter buried in sediments would, if anything, be expected to have higher N:P ratios than Redfield. Regardless of the nature of the N and P in sediments, if the sediment N:P ratio is at steady-state, then it should equal the N:P burial ratio. In that case,

$$(nfix-denit) = \Delta TN - 6.3 \Delta TP$$

This yields a value for $(nfix-denit)$ of $-0.43 \text{ mmol m}^{-2} \text{ d}^{-1}$, and for N burial of $0.13 \text{ mmol N m}^{-2} \text{ d}^{-1}$ (Table 2.17). The estimated DIP sink due to adsorption according to the benthic flux measurements is then 0.036 times denitrification, or $0.016 \text{ mmol P m}^{-2} \text{ d}^{-1}$, leaving a burial rate of organic P of $0.004 \text{ mmol m}^{-2} \text{ d}^{-1}$. The net sink of organic P in the Bay is $0.013 \text{ mmol m}^{-2} \text{ d}^{-1}$, so a burial rate of $0.004 \text{ mmol m}^{-2} \text{ d}^{-1}$ implies a net conversion of the organic P load to DIP amounting to $0.009 \text{ mmol m}^{-2} \text{ d}^{-1}$. At Redfield ratios, this implies a net respiration in the Bay of $0.95 \text{ mmol m}^{-2} \text{ d}^{-1}$. The further point about these fluxes, of course, is that they are very near 0.

Applying the bulk N:P ratio in sediments to estimate the ratio of TN:TP burial rates is only valid if the sediment composition is at steady-state. This is not necessarily true, because of the long time-scales associated with accumulation of the sediment pools. Rates of sediment accumulation in Port Phillip Bay are very low. The top 20 cm may represent about 1000 years of sediment accumulation, and isotope studies suggest bioturbation mixes this layer on time scales of about 20 years. At the estimated burial rates calculated above, it would take about 110 years to accumulate the observed sediment N and P pools in the top 20 cm. The Bay has been exposed to increasing nutrient loads for the last 150 years following European settlement. It is not clear that the ratio of N:P accumulation has remained constant over this period. However, the benthic chamber studies do provide direct evidence that DIP burial is continuing at a high rate.

Table 2.17 Comparison of N and P fluxes obtained under standard LOICZ interpretation (no DIP adsorption), and from direct measurements of benthic fluxes and sediment composition.

Flux ($\text{mmol m}^{-2} \text{ d}^{-1}$)	“Standard” LOICZ Interpretation	Benthic Chamber and Sediment Interpretation
DIP burial	0	0.016
Org P burial	0.020	0.004
Org C ($p-r$)	0.70	-0.95
$(nfix-denit)$	-0.37	-0.43
Org N burial	0.19	0.13

Conclusions.

In freshwater systems, burial of adsorbed inorganic P is often assumed to dominate internal sinks of TP. It is thought to be less important in estuarine and coastal systems, but the Port Phillip Bay example suggests we should be cautious about ignoring it. There is direct evidence from benthic chamber studies in Port Phillip Bay that DIP is adsorbed to sediments, and that ΔDIP should be interpreted primarily as DIP adsorption rather than burial of organic matter. In Port Phillip Bay, denitrification so dominates the N budget that the Bay is apparently net denitrifying regardless of the interpretation of ΔDIP . However, in other systems, ignoring DIP adsorption and burial could lead incorrectly to the conclusion that nitrogen fixation rates are large and dominate the N budget. Where data are sufficient to budget TN and TP, it may be possible to estimate DIP adsorption and burial by measuring the bulk N and P composition of the sediment.

Acknowledgements

The PPBES was funded by Melbourne Water. I acknowledge the efforts of a large number of PPBES participants who collected and analysed the data on which this budget is based.

2.6 DERWENT RIVER ESTUARY, TASMANIA

John Parslow

The Derwent River estuary (Site No. 23.; 147.30E, 42.90S) in Hobart, Tasmania (Figure 2.21; see Figure 1.1) is a drowned river valley, draining a large catchment, with (by Australian standards) consistently high runoff. Much of the catchment is undisturbed, although there is agricultural development in the downstream parts of the catchment. The city of Hobart sits astride the Derwent, and the estuary receives nutrient loads from a large number of small wastewater treatment plants (WTPs), and some industrial sources.

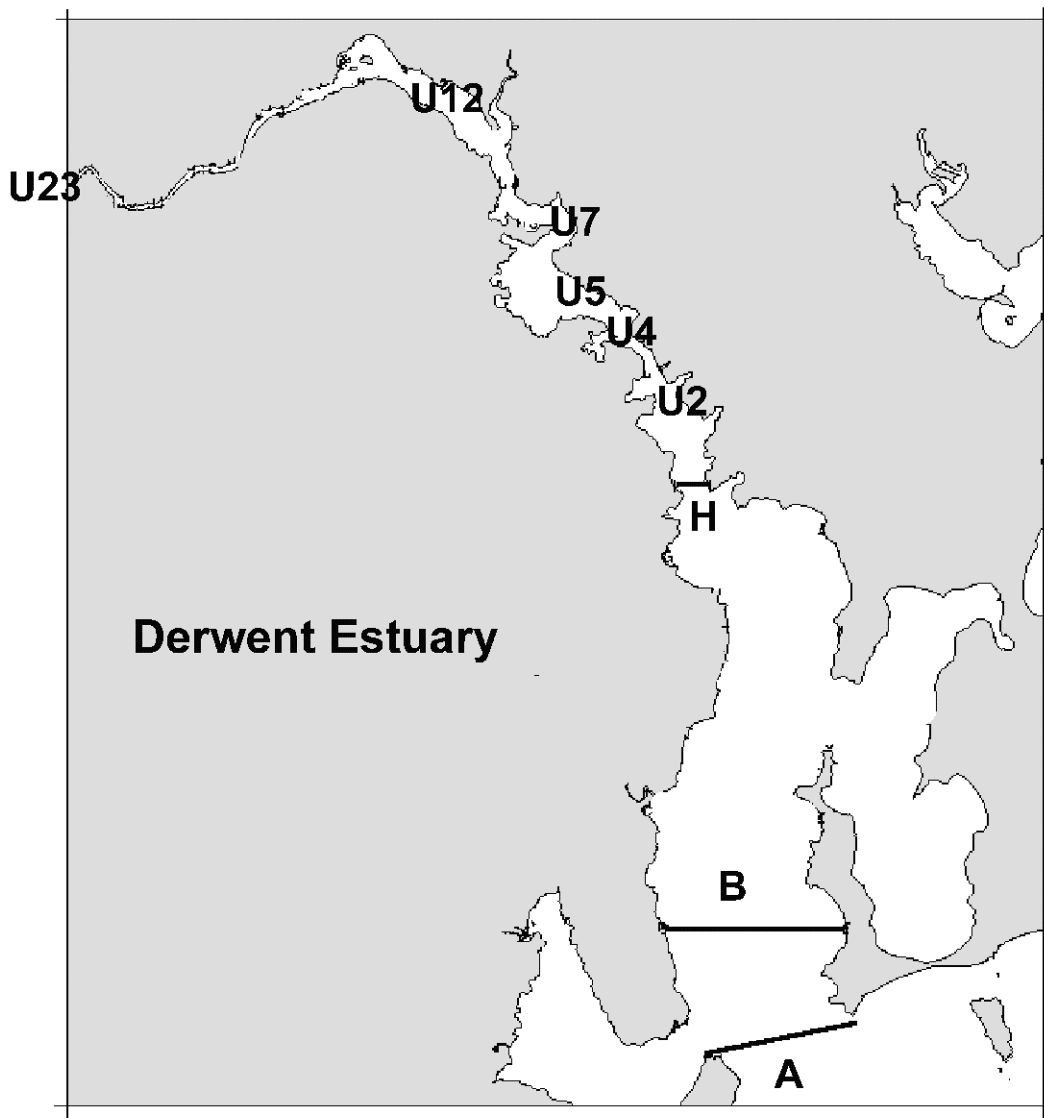

Figure 2.21 Derwent River estuary, showing sampling stations in CSIRO surveys.

The Derwent River estuary is relatively deep and, given the high runoff and low tidal amplitude, represents a classic example of a Pritchard-type salt-wedge estuary. The estuary can be divided length-wise into three sections (Figure 2.21). The upper estuary from New Norfolk down to just above Bridgewater, a distance of about 13 kms, is relatively narrow, and dominated by river flow. The middle estuary, from just above Bridgewater down to Hobart, is of the order of 1 km wide, and includes a number of shallow side embayments. The lower estuary, from Hobart to the Iron Pot, is much broader (order of 5 km) and generally marine-dominated. One might expect diffusive exchanges to be more important in the lower estuary.

The Derwent River discharge is by far the dominant freshwater input into the estuary. The river is dammed and used to generate hydro-electricity, so the discharge is strongly regulated. While flow may drop to about $20 \text{ m}^3 \text{ s}^{-1}$ for brief periods, it is typically greater than $50 \text{ m}^3 \text{ s}^{-1}$, and peak discharge can reach $300 \text{ m}^3 \text{ s}^{-1}$ (Coughanowr 1995).

Coughanowr (1995, 1997) provides estimates of average DIN and DIP loads from the WTPs and industrial sources along the Derwent. The point source loads in 1996 are summarised in Table 2.18. These loads are assumed to be constant within years.

Table 2.18 DIN and DIP loads from point sources (WTP and industrial) along the Derwent estuary.

LOCATION	DIN LOAD (mol d ⁻¹)	DIP LOAD (mol d ⁻¹)
U23	2 661	363
U21	12 369	1 669
U11	9 481	1 249
U6	1 536	502
U4	18 440	2 776
U3	7 617	857
U2	13 776	1 808
H	8 967	1 245
F	1 976	232
D	7 314	938
B	2 740	0

The Tasmanian Department of Environment and Land Management (DELM) conducted surveys of the Derwent River estuary in 1994 and 1996. Physical, chemical and biological properties were sampled at a series of locations along the length of the estuary, with some additional sampling in the side embayments. DELM has made available data collected in May 1994, and January, February, April and July 1996. Summaries of these data have been published in two technical reports (Coughanowr 1995, 1997), which also identify the principal industrial and WTP point sources, and provide estimates of nitrogen loads from these sources. (These reports also provide an excellent general description of the estuary and catchment.)

Biogeochemical Budgets for May 1994

In May 1994, salinity, DIN, DIP and TP were sampled top and bottom at 38 stations in the estuary, corresponding to a subset of the standard station grid shown in Figure 2.21. In the lower estuary, samples were collected at a number of stations on transects across the estuary, and these have been averaged to produce a 1-D set of top and bottom layer concentrations C_U and C_B at 25 locations along the estuary.

The estuary is budgeted by assuming that there is a classic 2-layer Pritchard-type circulation, with downstream flow in the top layer, upstream flow in the bottom layer, and vertical entrainment and mixing between top and bottom layers. We start by considering the net downstream flux of freshwater, salt and other tracers in the estuary. This is equivalent to the two-layer box models as illustrated in the LOICZ Guidelines (Gordon *et al.* 1996).

At any point along the estuary, if V_U is the downstream transport ($\text{m}^3 \text{s}^{-1}$) in the upper layer, V_B is the upstream transport in the lower layer, and V_Q is river runoff, then:

$$V_U = V_B + V_Q$$

The net downstream salt flux, given by $V_U \cdot S_U - V_B \cdot S_B$, must be zero, and it follows that:

$$V_B = V_Q S_U / (S_B - S_U)$$

The net downstream flux of any other tracer C at a given point along the estuary is then given by:

$$F = V_U C_U - C_B$$

Given the river runoff, V_Q , we have computed the upstream transport, V_B , and the net downstream flux of DIN, DIP and TP at each of the 25 locations where these tracers, plus salinity, were measured in top and bottom layers. The transport V_B is plotted versus distance downstream in Figure 2.22, and the net downstream flux of DIN and DIP (mol d^{-1}) are plotted versus distance downstream in Figure 2.23.

In an idealised steady-state 2-layer flow, the salinity in the top and bottom layers should increase monotonically downstream. The observed salinity in the top layer does increase monotonically, but the observed salinity in the bottom layer does not, due possibly to variations in both bottom depth and sampling depth along estuary, and to transverse variation or tidal aliasing in the lower estuary. Effects of this can be seen in Figure 2.22 where the transport, V_B , which should increase monotonically down the estuary, undergoes local fluctuations.

The estimated net downstream flux of DIN and DIP also fluctuates from point to point, in some cases changing sign. The DIN flux is low and positive and declines smoothly in the upper reaches of the estuary, and then increases but fluctuates substantially in the central

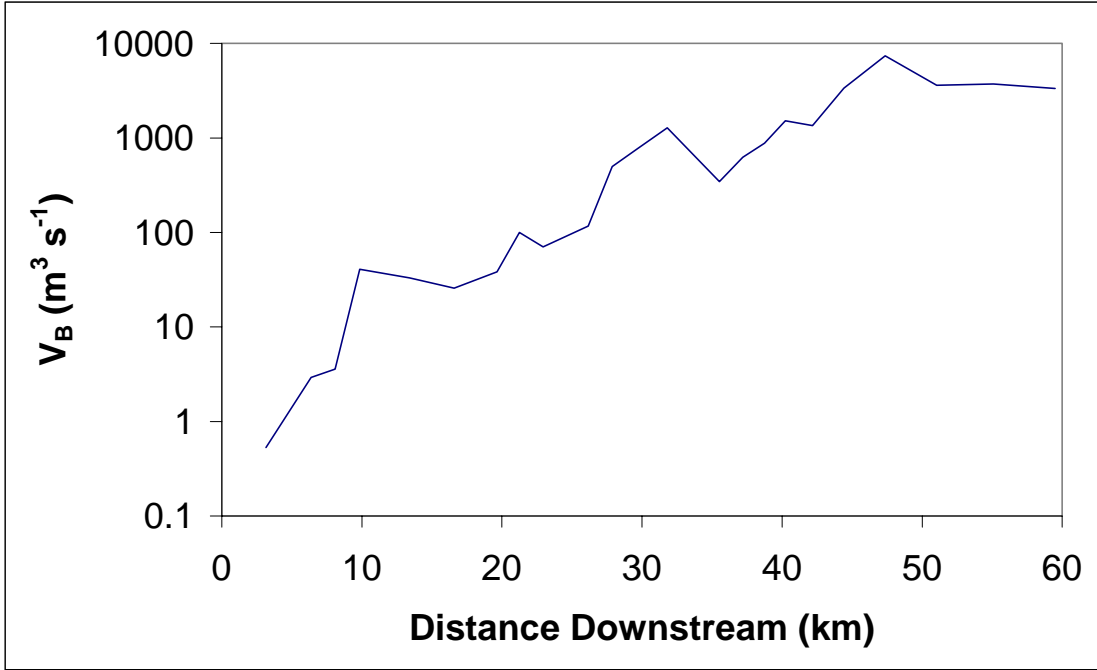

Figure 2.22 Calculated bottom transport V_B versus distance downstream, Derwent River estuary.

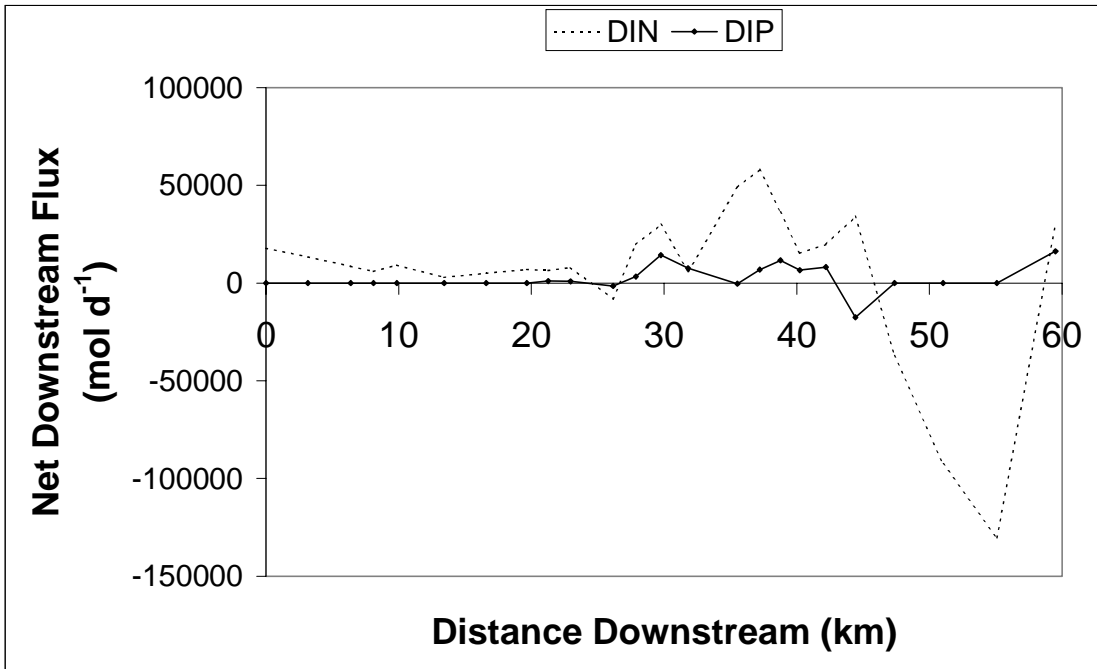

Figure 2.23 Net downstream flux of DIN and DIP versus distance downstream, Derwent River estuary.

reaches. The net flux depends strongly on the difference between upper and lower layer concentrations. In the central region, concentrations of DIN are elevated in both layers, with a small and variable difference between the layers. In the lower estuary DIN concentrations are slightly higher in the bottom layer and this, combined with the very large estimated transport, leads to a large estimated net flux of DIN upstream (i.e., into the estuary). However, this flux is very uncertain and in fact the concentration difference between lower and upper layers and the sign of the flux reverses at the mouth of the estuary.

In the case of DIP, the measured concentrations were below detection in the upper and lower reaches of the estuary in both top and bottom layers, resulting in zero flux estimates. Estimated fluxes were positive but variable in the middle reaches and at the mouth.

In principle, one could estimate the net source of DIN and DIP between each pair of observations by finding the difference between the net downstream fluxes. However, given the variability along the estuary, these local source-sink estimates are very noisy and difficult to interpret. Instead, we took the point source loads and locations in Table 2.18, and added these to the river load to give cumulative loads as a function of distance downstream. We then subtracted the cumulative load upstream of each sample point from the net downstream flux at that point, to estimate the net internal source upstream of each sample point. This is plotted versus distance downstream in Figure 2.24.

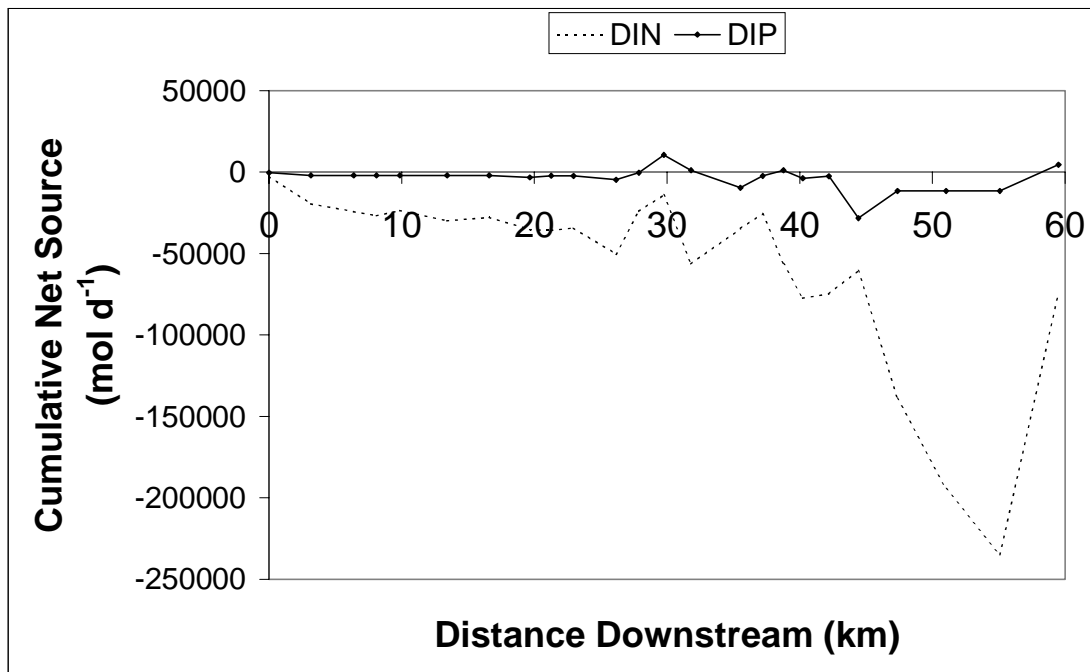

Figure 2.24 Calculated net source of DIN and DIP upstream of each sampling point versus distance downstream, Derwent River estuary.

On the basis of Figure 2.24, the estuary can be divided into three regions corresponding roughly to the upper, middle and lower estuaries. There is always a net sink of DIN throughout the estuary, i.e., the net downstream transport at each point is always less than the load upstream of that point. In the upper estuary, the net DIN sink increases smoothly with distance downstream. In the middle estuary, where most of the point source loads occur, the sink appears to continue to increase, but fluctuates substantially. In the lower estuary, there is apparently a very large sink but this reverses abruptly at the mouth.

There is a small net sink of DIP in the upper estuary, and this increases in magnitude but fluctuates in sign through the middle estuary. Again, there appears to be a large sink in the lower estuary, but this reverses to become a source at the mouth.

On the basis of Figure 2.24, we have computed regional budgets for three subregions: the upper, middle and lower estuary. These budgets are shown in Tables 2.19 and 2.20. In the upper estuary, DIN export is much less than load, so there is a large sink of DIN both in absolute terms and on an areal basis. A substantial fraction of the DIP load and the TP load is also lost to an internal sink. If the DIP sink is interpreted as organic carbon production, then there is a very high net rate of internal production (about 20 mmol m⁻² d⁻¹), and nitrogen fixation-denitrification is close to zero. On the other hand, if we interpret the DIP loss as due to adsorption to sediments, then there is a very high rate of denitrification. Either explanation is plausible, as this reach of the estuary is relatively fresh (salinity <10). There is little phytoplankton production, but in the lower reaches, there are shallow bays with extensive beds of macrophytes that could result in considerable net organic production. The upper estuary has also been subject to large loads of organic carbon from the ANM paper mill. These have produced anoxic mats that could lead to high rates of denitrification.

	mol d ⁻¹	Upper	Middle	Lower (B)	Lower (A)
DIN	Load	42 284	50 335	12 030	12 030
	Export	6 418	29 923	-166 723	-6 438
	Δ	-35 866	-20 412	-178 753	-18 468
DIP	Load	3 281	7 189	1 170	1 170
	Export	1 002	10 571	-11 573	4 593
	Δ	-2 280	3 382	-12 742	3 423
TP	Load	5 065	7 189	1 170	1 170
	Export	2 398	-4 164	6 895	-31 516
	Δ	-2 667	-11 353	5 725	-32 686

Table 2.19 Fluxes of DIN, DIP and TP for upper, middle and lower estuary, Derwent River. (Upper estuary extends downstream to sampling point U10, middle estuary to H on Figure 2.21. Two budgets are presented for the lower estuary, upstream of transects B and A respectively. We consider the lower estuary calculation at transect B to be the more reliable.)

	mmol m ⁻² d ⁻¹	Upper	Middle	Lower (B)	Lower (A)
DIN	Load	3.46	2.12	0.10	0.09
	Δ	-2.94	-0.86	-1.48	-0.14
DIP	Load	0.27	0.30	0.01	0.01
	Δ	-0.19	0.14	-0.11	0.03
TP	Load	0.41	0.30	0.01	0.01
	Δ	-0.22	-0.48	0.05	-0.24
	(<i>p-r</i>)	19.80	-15.07	11.22	-2.68
	(<i>nfix-denit</i>)	0.05	-3.13	0.21	-0.54

Table 2.20 Fluxes of DIN, DIP and TP for upper, middle and lower estuary, Derwent River, as defined in Table 2. (Net ecosystem production (*p-r*) and nitrogen fixation-denitrification (*nfix-denit*) are calculated as suggested by the LOICZ methodology, assuming Redfield ratios.)

In the middle estuary, DIN export is less than loads and there is again a substantial internal DIN sink, although this is much smaller on a per area basis. There is apparently a DIP source in this section, which could be due to release of P from bottom sediments. However, the magnitude of this source is uncertain, given long-stream variation in DIP transport. If one interprets the DIP source as being due to breakdown of organic matter at Redfield ratios, this is a region of net respiration and very high rates of denitrification per unit area. If the DIP source is inorganic particulate P, then this is a region of moderate denitrification.

Budgets in the lower estuary vary considerably, depending on whether the marine boundary is set at sampling transect A or B. If the boundary is set at B, there is a large flux of DIN and DIP into the estuary from offshore, and a large internal sink of DIN and DIP. If this is converted to organic matter at Redfield ratios, it implies high net ecosystem production in the lower box. The DIN and DIP influx are close to Redfield balance, and the calculated net rate of nitrogen fixation is small compared with the DIN sink, and insignificant given the uncertainties in fluxes. If the boundary is set at A, the marine influx disappears, and the internal sink of DIN in the lower estuary becomes quite small. The net DIP source is essentially zero. It is unclear whether this variation represents a real characteristic of the system or uncertain results.

It is possible by budgeting salt and freshwater to estimate the fluxes due to vertical entrainment and vertical mixing in each section of the estuary, and therefore to compute the net sources of DIN and DIP in top and bottom layers separately. We have carried out these computations both between each pair of sampling points and for the broad regions (upper, middle and lower) just discussed. However, these computations are even more sensitive to small errors in observations, and both sets of calculations give very large compensating sources and sinks in top and bottom layers. We have decided not to present them here until the error terms in the budgets are better understood.

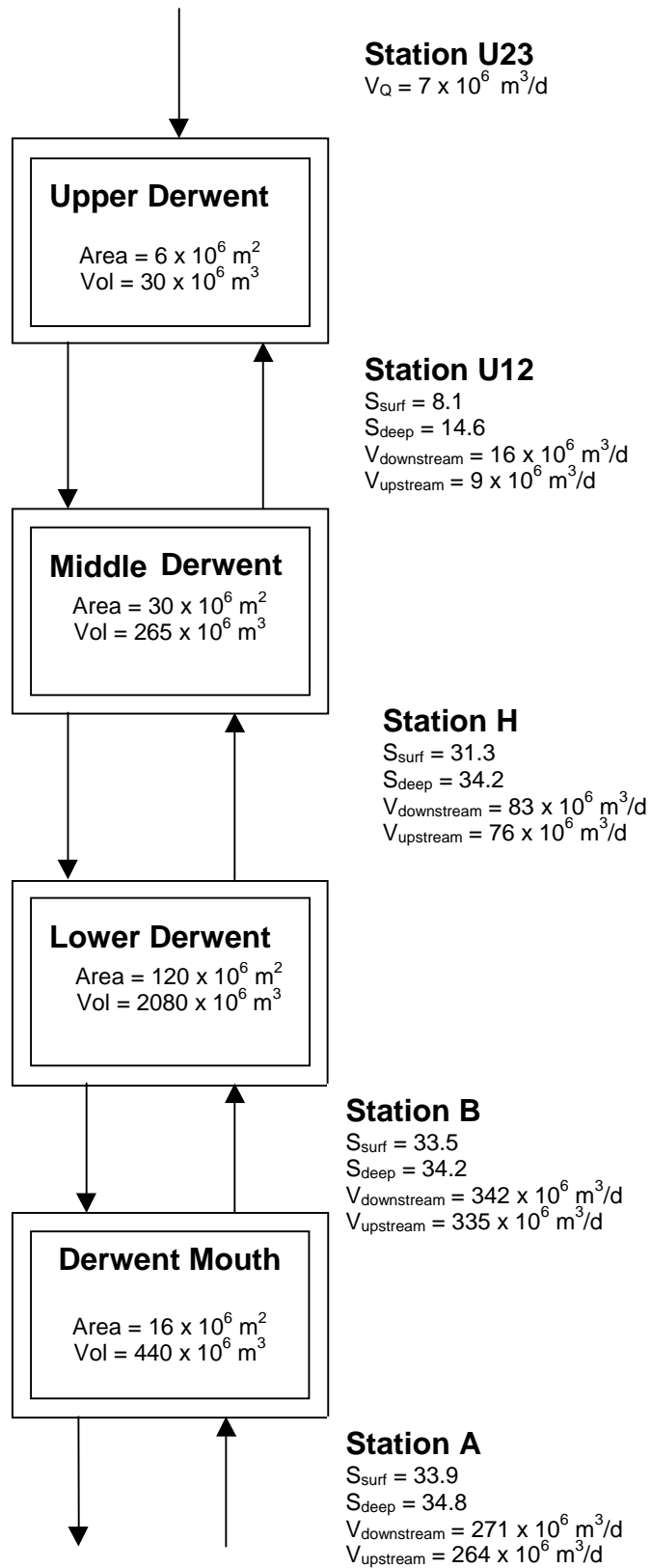

Figure 2.25 Water and salt budgets, Derwent River estuary.

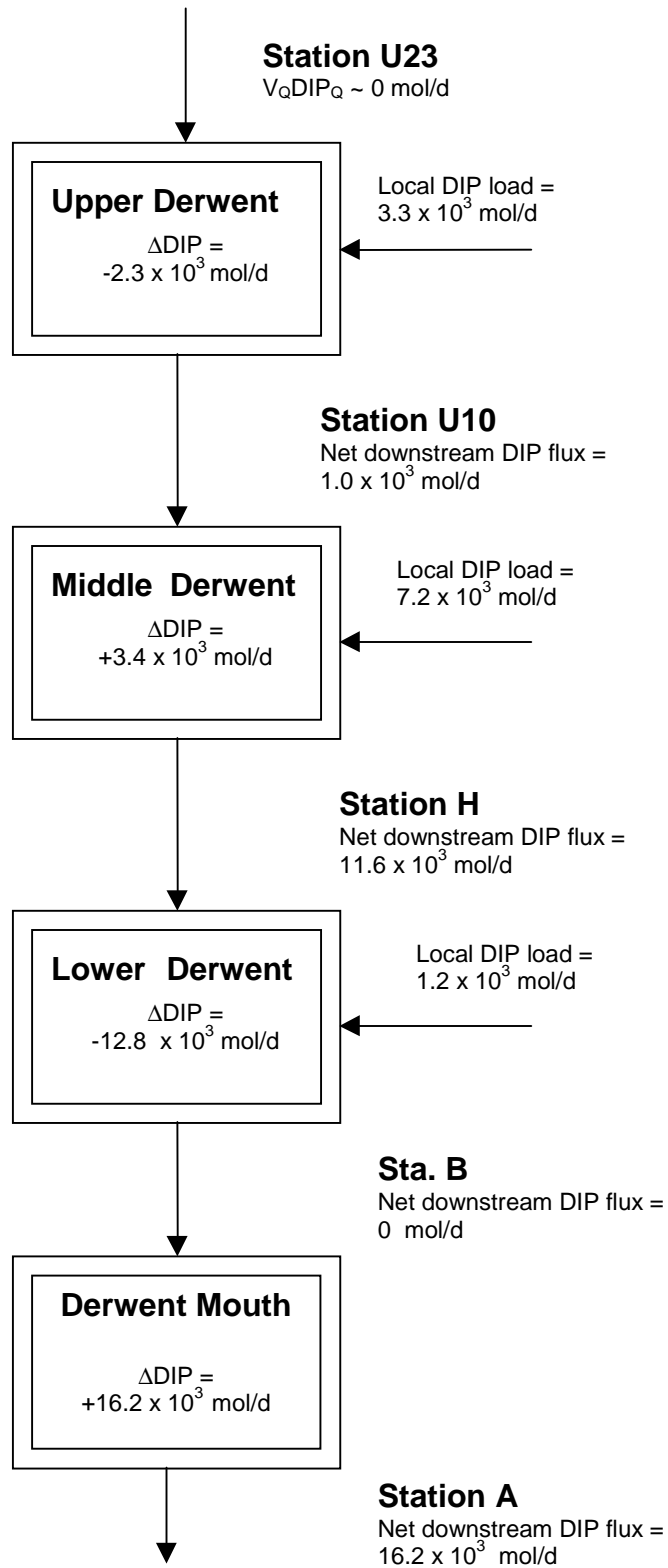

Figure 2.26 DIP budget, Derwent River estuary.

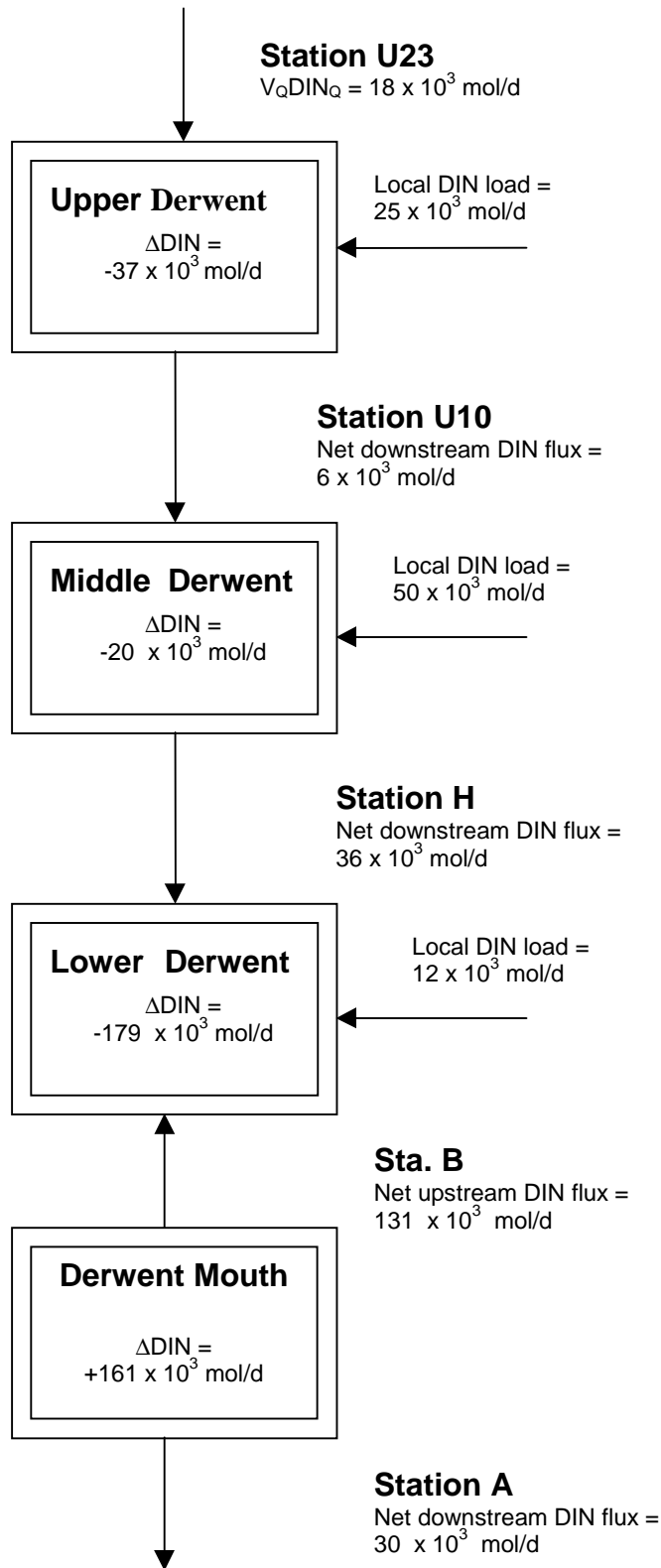

Figure 2.27 DIN budget, Derwent River estuary.

Figures 2.25-2.27 convert the calculations presented above into LOICZ-style box diagrams for the various sectors. The water exchange time for the whole estuary (system volume divided by the downstream water flux; Figure 2.27) is approximately 10 days. While the division into estuary segments is desirable to estimate the fluxes precisely, the water exchange times in each sector are very short (2-4 days for the upper and middle sectors). Therefore, we conclude that the overall system budgets based on accumulation of the data for the whole estuary provide the most robust estimates of system performance. The analysis by subsector is presented for illustrative purposes only.

ΔDIP for the entire estuary totals +4,500 mol/day, equivalent to +0.03 mmol m⁻² d⁻¹. This is converted to an estimate of (*p-r*) by multiplying by -106, on the assumption that organic metabolism is dominated by plankton; (*p-r*) is estimated by the LOICZ procedures to be -3 mmol m⁻² d⁻¹. According to this interpretation, the system is slightly net heterotrophic, although the difference from 0 is probably insignificant. ΔDIN for the system is -75,000 mol/d, or -0.4 mmol m⁻² d⁻¹; (*netix-denit*) is calculated as $\Delta\text{DIN}_{\text{obs}} - \Delta\text{DIN}_{\text{exp}}$, or -0.9 mmol m⁻² d⁻¹.

Budgets for January, February, April and July 1996

Data are not available for a full annual cycle. However, DELM conducted some further surveys in 1996. On these surveys, DIN, DIP, TN and TP were measured. Unfortunately the bottom layer was only sampled on these surveys at one or two stations in mid-estuary. Consequently it has only been possible to compute net downstream fluxes at these stations and net budgets for regions of the estuary upstream of these stations. The budgets are summarised in Table 2.21. We present these budgets to give a sense of the seasonal variation in the non-conservative fluxes, with the caveat given above that we do not place a great deal of confidence in either the non-conservative performance of the budgets or the stoichiometric interpretations based on the upper estuary, due to very short water residence time and relatively low salinity of this portion of the estuary. Because slightly different stations are used for each calculation, the nonconservative fluxes are simply presented as normalised per unit area.

Export of DIN is consistently much less than the DIN load, and in February and April there is a weak net flux of DIN upstream at one or both stations. In July there is a large net upstream flux of DIN, driven by elevated nitrate due to winter mixing on the adjacent continental shelf. Consequently, the budgets consistently show a large internal sink of DIN, ranging from 1.4 to 5.6 mmol m⁻² d⁻¹.

The net export of TN is always positive and, except in January, represents a substantial fraction of the load. There is still a substantial sink of TN within the estuary, ranging from 1.9 to 5.8 mmol m⁻² d⁻¹, except in July, when this sink is only 0.8 mmol m⁻² d⁻¹.

DIP behaves much like DIN – the export is always less than load, and in some months, especially July, there is a significant influx of DIP from the ocean. The net sink of DIP within the estuary ranges from 0.14 to 0.8 mmol m⁻² d⁻¹. If this is assumed converted to organic matter at Redfield ratios, it represents extremely high rates of net community production, up to 87 mmol C m⁻² d⁻¹ in July. If real, this is unlikely to represent

Table 2.21 Calculated budgets for region of Derwent River estuary upstream of nominated sampling stations, in 1996.

	DIN	TN	DIP	TP	(<i>nfix-denit</i>)	(<i>p-r</i>)
JANUARY (R = 60 m³ s⁻¹)						
U5 (V_B=241 m³ s⁻¹)						
Export (mol d ⁻¹)	1 550	3 753	104	-179		
Load (mol d ⁻¹)	34 872	120 717	4 145	5 232		
Δ (mol d ⁻¹)	-33 323	-116 964	-4 041	-5 411	31 334	428 350
Δ (mmol m ⁻² d ⁻¹)	-1.37	-4.79	-0.17	-0.22	1.28	17.55
FEBRUARY (R = 100 m³ s⁻¹)						
U7 (V_B=27 m³ s⁻¹)						
Export (mol d ⁻¹)	-2 900	119 058	-499	2 242		
Load (mol d ⁻¹)	36 237	163 368	3 839	5 232		
Δ (mol d ⁻¹)	-39 137	-44 311	-4 337	-2 990	30 261	459 762
Δ (mmol m ⁻² d ⁻¹)	-2.42	-2.74	-0.27	-0.19	1.87	28.45
U4 (V_B=81 m³ s⁻¹)						
Export (mol d ⁻¹)	-9 007	113 371	-1 265	1 959		
Load (mol d ⁻¹)	56 222	183 353	7 124	8 517		
Δ (mol d ⁻¹)	-65 229	-69 982	-8 389	-6 559	69 000	889 267
Δ (mmol m ⁻² d ⁻¹)	-2.43	-2.60	-0.31	-0.24	2.57	33.10
APRIL (R = 200 m³ s⁻¹)						
U5 (V_B=106 m³ s⁻¹)						
Export (mol d ⁻¹)	2 496	180 095	1 477	6 034		
Load (mol d ⁻¹)	92 699	321 042	4 898	6 570		
Δ (mol d ⁻¹)	-90 202	-140 946	-3 420	-536	-35 474	362 572
Δ (mmol m ⁻² d ⁻¹)	-3.69	-5.77	-0.14	-0.02	-1.45	14.85
U2 (V_B=329 m³ s⁻¹)						
Export (mol d ⁻¹)	21 490	286 718	-8 366	2 346		
Load (mol d ⁻¹)	132 531	360 874	10 339	12 012		
Δ (mol d ⁻¹)	-111 041	-74 156	-18 705	-9 665	188 240	1 982 741
Δ (mmol m ⁻² d ⁻¹)	-3.55	-2.37	-0.60	-0.31	6.02	63.38
JULY R = 90 m³ s⁻¹						
U5 (V_B=175 m³ s⁻¹)						
Export (mol d ⁻¹)	-46 503	71 985	-9 922	1 405		
Load (mol d ⁻¹)	51 597	81 590	4 285	4 786		
Δ (mol d ⁻¹)	-98 100	-9 605	-14 206	-3 381	129 203	1 505 883
Δ (mmol m ⁻² d ⁻¹)	-4.02	-0.39	-0.58	-0.14	5.29	61.69
U2 (V_B=455 m³ s⁻¹)						
Export (mol d ⁻¹)	-83 034	95 469	-16 021	-3 127		
LOAD (mol d ⁻¹)	91 430	121 423	9 726	10 228		
Δ (mol d ⁻¹)	-174 464	-25 953	-25 748	-13 355	237 497	2 729 243
Δ (mmol m ⁻² d ⁻¹)	-5.58	-0.83	-0.82	-0.43	7.59	87.24

phytoplankton production, as phytoplankton biomass is low and phytoplankton production appears to be heavily light-limited in winter.

Except for station U5 in April, the DIP sink times Redfield N:P ratio always exceeds the DIN sink, so that if the DIP sink is interpreted as being due to organic matter production, it implies net N-fixation. Very high rates of N-fixation are estimated in this way in April and July. This interpretation does not seem plausible, as it implies high rates of N-fixation at a time when light and temperatures are low, and DIN concentrations in the water column are elevated. This situation may represent burial of P as inorganic material, or it may simply be an artifact of budgeting a region with an excessively short exchange time.

The export flux of TP is generally greater than the export flux of DIP, except in January. In July, when there is a large influx of DIP past both stations, there is a significant efflux of TP past the upstream station, and only a small influx past the downstream station. Internal TP sinks are significantly smaller than DIP sinks, so that a significant portion of the DIP sink is exported either as adsorbed inorganic particulate P or as organic P.

Conclusions

The May 1994 budget showed considerable local variation in downstream fluxes in the middle estuary. This suggests that the calculated budgets in 1996, based on one or two stations in the middle estuary, are subject to significant errors, which could be exaggerated in the calculation of derived quantities such as (*nfix-denit*). This is particularly a problem, given the very short water residence time in the upper portion of the estuary. On the other hand, the 1994 and 1996 budgets consistently show large sinks of DIN and DIP in the upper and middle estuary, both in summer, when point source loads are the dominant inputs, and in winter, when influx from the adjacent continental shelf dominates. These sinks must be attributed either to high rates of organic matter production and burial/export, or to high rates of DIP adsorption and denitrification. Light attenuation is high in the Derwent River estuary, and phytoplankton biomass and production are strongly light-limited. High net rates of organic matter production may be associated with benthic macrophytes in shallow side embayments in the middle estuary. High rates of denitrification may be facilitated by historically large loads of organic carbon from the ANM paper mill.

2.7 COCKBURN SOUND, WESTERN AUSTRALIA

A. W. Chiffings

Cockburn Sound (Site No.28.; 115.80E, 32.20S) is the largest of several coastal embayments immediately south of the port of Fremantle on the Western Australian coast (Figure 2.28; see Figure 1.1). The Sound has a 45-year history of ecosystem change as a result of perturbations from industrial development over this time. Scientific studies have been undertaken on the Sound since the late 1970s and much of this effort has been focused on gaining an understanding of key physical, biochemical and biological processes. As a result of these studies it is thought now to be possible to look at long-term changes in the Sound from a systems point of view, particularly in terms of nutrient materials flux using the LOICZ approach (Gordon *et al.*, 1996).

The initial models presented here have been prepared using data obtained from a study (1977 – 1983) that gained a quantitative understanding of the relative importance of physical exchange and mixing processes, nutrient additions and sediment recycling to phytoplankton-nutrient interrelations in the nearshore coastal waters of the region.

As time permits, models based on the subsequent studies through to the most recent studies (1994) are being prepared so that comparisons can be made of the impacts of changes in both ecosystem functioning and nutrient loading regimes on overall behaviour of the system.

Study Area Description

Cockburn Sound is one of four coastal basins formed from the flooding of a depression between Pleistocene aeolianite ridges running north-south, and the subsequent deposition of east-west Holocene banks (Churchill 1959, France 1978). Warnbro Sound, the southern embayment, is separated from Cockburn Sound by a Holocene bank overlain by a series of emergent beach ridges (Fairbridge 1950, Wood 1983). The banks separating Cockburn Sound from Owen Anchorage (Parmelia Bank), and Owen Anchorage from Gage Roads (Success Bank), are submerged shallows covered to a considerable extent by seagrasses (Cambridge 1975). Gage Roads, the northern-most basin, is open to the north. The Swan-Canning River system enters Gage Roads at the port of Fremantle (Figure 2.28), with the Peel-Harvey estuary and riverine system entering the coast some 16 kms to the south of Warnbro Sound.

The eroded aeolianite ridge on the western side of the embayments forms a chain of submerged and partly exposed reefs, rocky outcrops and islands of various size. The largest of the islands, Garden Island, makes up the predominant part of the western boundary of Cockburn Sound.

Cockburn Sound has a surface area of 114 km² and a mean depth of 12 m. It is almost entirely made up of a deep basin (16-20 m deep) with shallow margins that were once covered by seagrass. These margins extend out into a broad shelf (approximately 3 km wide and 4-7 m deep) between James Point and Woodman Point along the eastern side of the Sound. The other dominant feature is an extensive shallow sand flat in the south

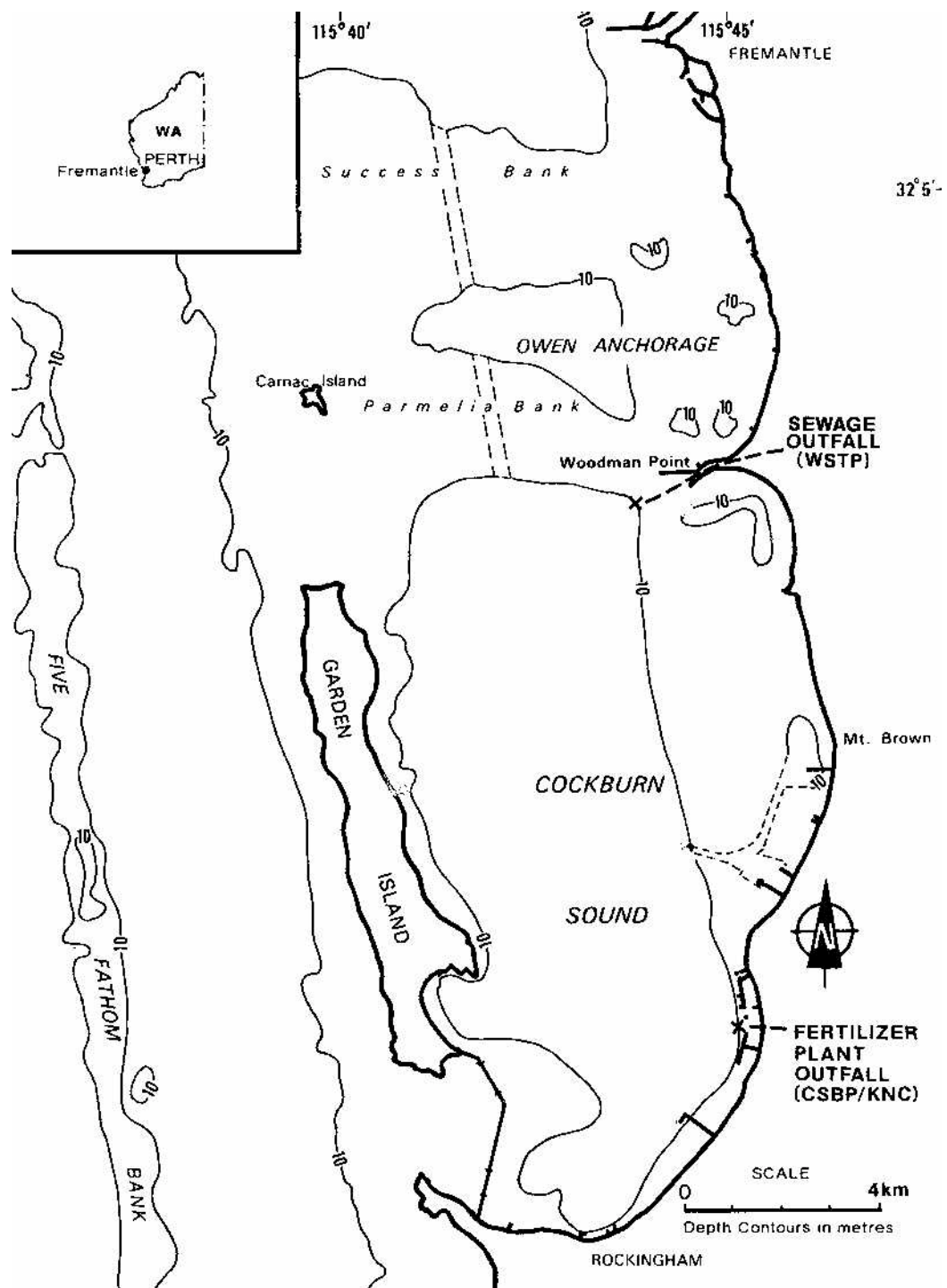

Figure 2.28 Map of Cockburn Sound, Western Australia.

(Southern Flats) between Garden Island and the mainland, which extends into the southern part of the deep basin of the Sound.

Up until the 1970s, the margins of the Sound and the Southern Flats were covered in dense beds of the seagrass genus *Posidonia*. These beds extended from the immediate subtidal to a depth of 8-10m. It has been calculated that from 1957 through to 1968 a gradual thinning of the seagrass beds took place and by 1972, all but about 7 km² of an original 40 km² had disappeared (Cambridge 1975). A reassessment in 1994 derived an estimate of 7.5 km², although it is known that there has also been a reduction in seagrass areas on the Southern Flat as well as Parmelia Bank to the north (DEP 1996).

Loss of seagrass was considered a result of diminished light, initially due to increased epiphytic loads on the seagrass, and then increasing phytoplankton concentrations. Both of these changes in primary production resulted from increased nutrient loads to the Sound from industrial sources.

Cockburn Sound has been extensively developed as the Outer Harbour of the port of Fremantle. Since 1954, much of the eastern shore has been developed for industrial use with adjacent port facilities. Some of the larger industries use water from Cockburn Sound for cooling purposes and a number of these industries also discharge wastes to the Sound. The mainland shore of Owen Anchorage is also heavily industrialised. As a noxious industries zone it has a number of abattoirs, food processing plants and tanneries. Some of their discharge wastes go directly to the Anchorage or to the groundwater (Murphy 1979).

Water Balance

In the present analysis, water exchange is based on numerical modelling of circulation, rather than on a water and salt budget. Exchange between the open ocean and Cockburn Sound may take place either in the south, through the two openings in the causeway which links Garden Island to the mainland, or through the northern opening of the Sound, across Challenger Passage (between Garden Island and Carnac Island) and Parmelia Bank (between Carnac Island and Woodman Point) (Figure 2.28).

At the time of the initial studies, exchange through the two southern openings was considered to be of minor importance (Steedman and Craig 1983) based on both numerical model predictions and field observations. Subsequent studies indicate that southern exchange is greater than originally anticipated (20-30% of total exchange – Mills and D'Adamo 1995). This needs to be borne in mind when considering the budgets presented, as they use modelled exchange rates based on the major exchange between Cockburn Sound and the open ocean taking place across the northern boundary.

The numerical model of Steedman and Craig was initially used to calculate northern exchange rates. The algorithm distinguished between water exchange by a small gyre on the western side of the Sound, and that of a larger gyre on the eastern side. As calculation of the total volume exchange between each cruise would have involved the expense of running the model for long periods, an empirical relationship was sought

between predicted northern exchange and wind stress. Wind is the primary forcing function for water movement in Cockburn Sound (Steedman and Craig 1979, 1983).

A direct relationship between wind speed and direction and exchange volumes, predicted by the numerical model, was established by Steedman and Craig for the eastern gyre. Calculated exchange rates using only wind speed and direction correlated well with rates obtained from the numerical model. Predicted exchange associated with the western gyre was found to be reasonably consistent under most conditions, the average volume exchanged being $70 \times 10^6 \text{ m}^3 \text{ d}^{-1}$. Flux by this western gyre was therefore treated as a constant in subsequent calculation of northern volume flux.

Salinity differences between Cockburn Sound and the ocean are great enough to allow LOICZ-style mass balance estimates to be made. This needs to be done to ascertain the sensitivity of the model predictions to differences in exchange calculations.

Basis for Budget Calculations

The budgets presented here are based on 12 months of data collected in 1980 from 14 cruises over a period of 365 days. These data are part of a more extensive record of cruises undertaken between 1977 and 1983 (Chiffings 1987).

Input parameters to the material flux model used were the external nutrient load to the Sound, and the northern exchange volume flux. The external nutrient load for each monthly period was estimated by adding the loads from the fertiliser plant outfall and the sewage plant, as these had been identified as contributing some 72% of the DIN to the system and 89% of the DIP to the system. An estimate for other, previously identified sources of nutrients was added as a constant.

The mean exchange time for the 12 month period was 152 days. This is equivalent to an exchange volume (V_X) of about $9 \times 10^6 \text{ m}^3 \text{ d}^{-1}$, or $3.3 \times 10^9 \text{ m}^3 \text{ y}^{-1}$. Summer residence times were calculated as an average of 100 days ($V_X = 14 \times 10^6 \text{ m}^3 \text{ d}^{-1}$), compared with a winter average of 200 days ($7 \times 10^6 \text{ m}^3 \text{ d}^{-1}$). This increase in oceanic exchange over the summer period, November to March, reflects strong sea breezes that lead to large exchange volumes through the northern opening. Large volumes were also exchanged during periods of frequent and persistent storms over the winter period (June-September). However, these storm events were less predictable and of short duration, with the passage of low pressure weather systems resulting in strong winds being interspersed with periods of calm conditions and therefore minimal exchange.

There are no natural drainage systems discharging to Owen Anchorage, Cockburn Sound or Warnbro Sound. Surface runoff is restricted to a small number of stormwater drains associated with urban and industrial development. Urban runoff contains nitrogen and phosphorus (Anonymous 1973), but in view of the magnitude of inputs from other sources, the possible contribution from stormwater drainage was assumed to be insignificant. The nearest river discharge is from the Swan Canning system, which discharges some 3.5 km north of Success Bank, the northern boundary of Owen Anchorage. During the budget period under consideration here, freshwater inflow from

this river system was considered not to be a significant source of nutrients to the Sound. Since freshwater load is small, residual flow (V_R in the standard LOICZ calculations) can be considered to be zero, although this is not always the case (DEP 1996).

Groundwater flow in the shallow, unconfined aquifers to the south of Fremantle was estimated by flow-net analysis (Davidson 1981). These estimates, in conjunction with nutrient concentration data from bores close to the coast (Layton Groundwater Consultants 1979), have been used here to calculate inorganic nutrient loads to Cockburn Sound.

During the study, four industries were using water from the Sound for cooling purposes and waste disposal. Comprehensive studies were made of the composition of these discharges (Murphy 1979). An estimate for the Woodman Point Sewage Treatment Plant (WPSTP-primary treated sewage) is also included, based on weekly nutrient concentration and flow data provided by the Metropolitan Water Supply Sewage and Drainage Board. The sum of these loads to the system has been expressed as Y_{terrig} in the nutrient budgets.

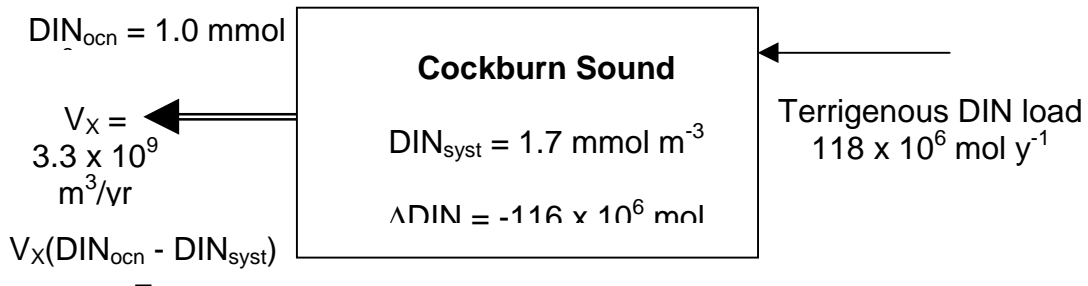
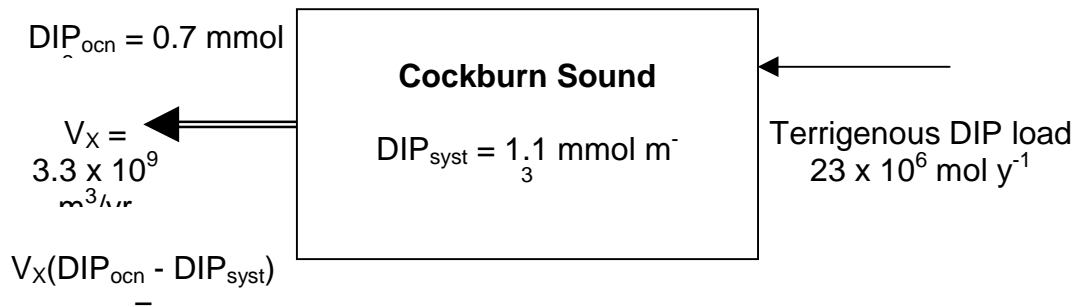

Figure 2.29 Annual DIP and DIN budgets during 1980, Cockburn Sound.

Nutrient Budgets

The original flux estimations were done for TN and TP and have been recalculated here for DIN and DIP using average ratios for the total external loads to the Sound (Figure 2.29). System concentration was calculated as the average of a sampling station located at the north-eastern end of the Sound. The coastal reference station was one located in the south-western part of Owen Anchorage.

Stoichiometric Analysis

Based on the above budgets and following the methods of Gordon *et al.* (1996), the following stoichiometric relationships were derived. Expressed on an areal basis, $\Delta\text{DIP} = -0.19 \text{ mol m}^{-2} \text{ yr}^{-1}$, and $\Delta\text{DIN} = -1.1 \text{ mol m}^{-2} \text{ yr}^{-1}$. The system appears to be a net sink as virtually none of the DIP and entering DIN is transported out of the system.

As most of the seagrass cover is now gone, the stoichiometric calculations are based on phytoplankton as the major DIP sink. Net ecosystem production ($p-r$) is thus calculated as $-106 \times \Delta\text{DIP} = 20 \text{ mol m}^{-2} \text{ yr}^{-1}$ (or $+55 \text{ mmol m}^{-2} \text{ d}^{-1}$). This seems to be a high rate of net production, perhaps indicating an inorganic sink for the DIP or perhaps reflecting uncertainty in the water exchange.

Nitrogen fixation minus denitrification (*nfix-denit*) is estimated as the observed ΔDIN ($\Delta\text{DIN}_{\text{obs}} = -1.1 \text{ mol m}^{-2} \text{ yr}^{-1}$) minus that expected based on ΔDIP . Again, based on the assumption that phytoplankton constitute the major primary producers in the system, we estimate $\Delta\text{DIN}_{\text{exp}}$ as $16 \times \Delta\text{DIP}$; $-3.0 \text{ mol m}^{-2} \text{ yr}^{-1}$. This leads to an estimated rate of (*nfix-denit*) of $+1.9 \text{ mol m}^{-2} \text{ yr}^{-1}$ ($+5.2 \text{ mmol m}^{-2} \text{ d}^{-1}$). This value seems a remarkably rapid rate of apparent net nitrogen fixation for this system, again possibly reflecting some uncertainty with the DIP budget.

Future Work

Cockburn Sound has been the subject of considerable study since 1980. Summer surveys of nutrient concentrations were undertaken in 1982/3, 1984/5, 1986/7 and then again in 1989/90 through to 1993/94, when another major study was undertaken (Anonymous 1996). During the latest intensive study a greatly refined quantitative understanding of the circulation and exchange processes was obtained (DEP 1996). In the intervening period between the studies, there has been a considerable change in both sources and total loads of nutrients to the system. In short, the Sound represents an opportunity to look more carefully at the long-term impacts of nutrient loadings on a temperate coastal ecosystem. New budgets will be developed as time permits, to fully explore these changes.

2.8 SWAN CANNING ESTUARY, WESTERN AUSTRALIA
Linda Kalnejais, Kathryn McMahon and Malcolm Robb

Study Area Description

The Swan Canning estuary (Site No. 29.; 115.90E, 32.00S) is located on the Swan Coastal Plain, Western Australia (Figure 2.30; see Figure 1.1). The total catchment of the estuary is 141 000 km², with the coastal plain covering 2 117 km². The majority of the catchment is cleared for agriculture, with intensive agriculture, grazing, light industry and housing on the coastal plain. The Swan Canning estuary runs through the city of Perth, which has a population of over 1.2 million people.

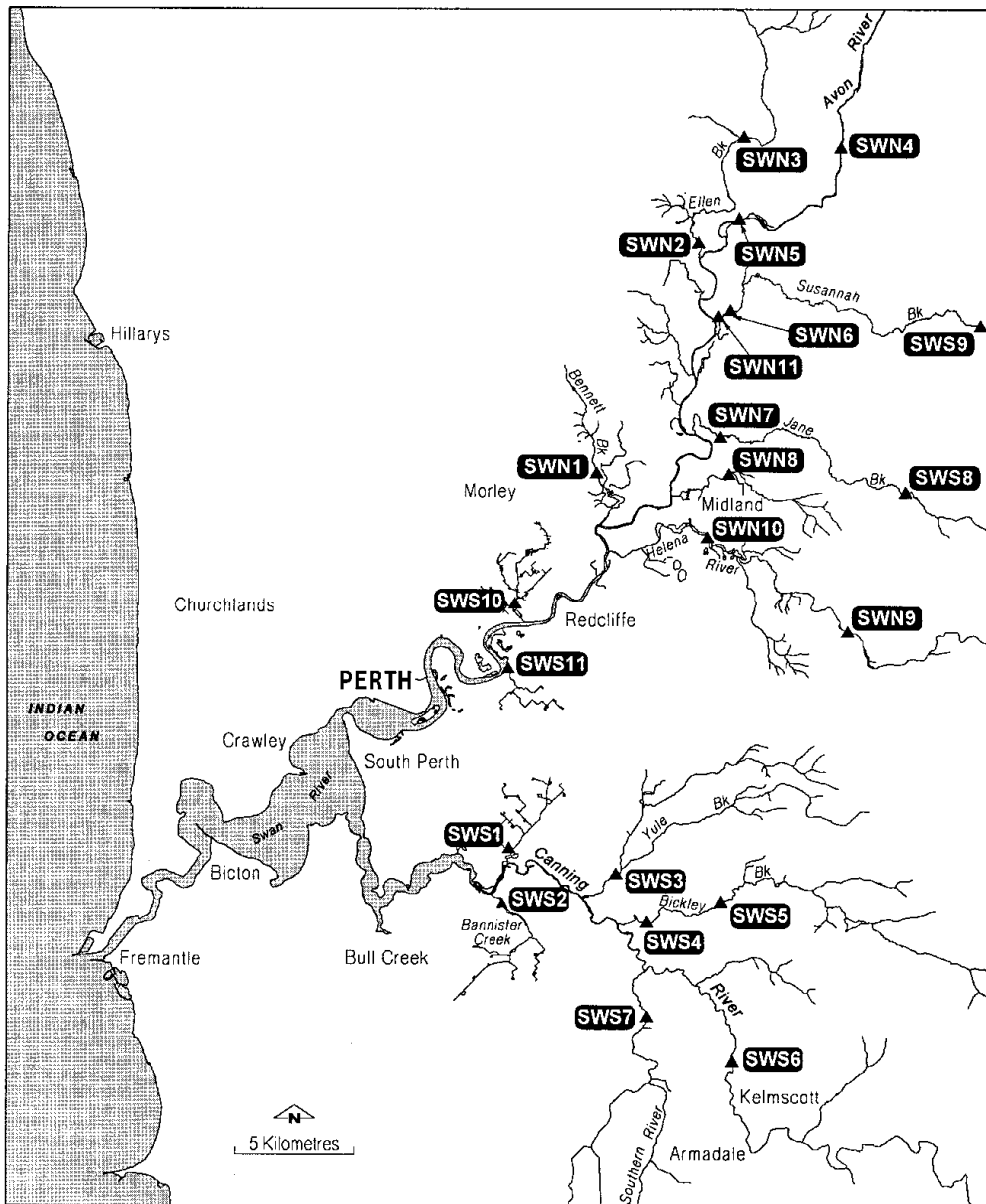

Figure 2.30 Swan Canning estuary. (The sites shown are the Water and Rivers Commission water quality monitoring sites.)

The Swan Canning estuary is permanently connected with the Indian Ocean at Fremantle. The estuary is deepest in the lower portions (10 to 20 m), with a shallow sill (3 m to 5 m deep) 5 kms from the harbour mouth which controls water exchange with the ocean. The estuary width ranges from 20 m to 1.5 km wide, with an average width of 230 m. From the Perth the river meanders upstream with an average depth of 2 m to 3 m, punctuated with holes of 5 m to 6 m. The tidal portion of the river is 50 km long, with a surface area of 33 km². The upper portion of the estuary occupies about 3 km² and has a mean depth of about 3.7 m, while the lower portion occupies 30 km² and has a mean depth of 4.9 m. Average tidal variation in the estuary is 0.5 m.

The Swan Canning estuary undergoes a distinct seasonal cycle of stratification (Stevens and Imberger 1996). Over summer (the low rainfall period), there is a gradual increase in salinity due to the upstream movement of the salt wedge. There is a strongly seasonal discharge of freshwater from the catchment, with most rain falling between May and September. Peak runoff occurs during winter and the saline estuarine water is usually flushed from the upper estuary, resulting in a vertically well-mixed water column in the shallow upper estuary. The freshwater discharge moves downstream as a buoyant plume and the lower estuary stratifies. As river flows reduce in October and November, the saline water migrates upstream as a salt wedge and salinity stratification is re-established in the upper estuary.

The dominant primary producers are phytoplankton which have been detected in bloom proportions in all sections of the estuary at various times, but are most significant in the upper reaches, blooming in spring, summer and autumn. Benthic macroalgae and the seagrass *Halophila* grow in the lower reaches of the estuary.

The Water and Rivers Commission has routinely monitored water quality in the Swan Canning estuary and its coastal plain catchment since 1994. Fifteen major catchment inflows have been monitored weekly for total and dissolved nutrients, when they were flowing. Nine estuary sites have been monitored for the above nutrients; vertical profiles measured for salinity, temperature, oxygen; and water samples collected to estimate phytoplankton density, on a weekly basis. The data collected from these programs has been used for LOICZ-style budgeting (Gordon *et al.* 1996), along with other data.

LOICZ Budgeting Guidelines

The following equation for the conservation of mass can be applied to any system:

$$\frac{dM}{dt} = \sum Inputs - \sum Sinks + \sum [Sources - Sinks] \quad (1)$$

where M is the mass of a particular material. This equation represents the rates and quantities of material movement through the system and includes the effects of internal sources and sinks.

The LOICZ procedure applies this equation to water, salt and nutrients in order to obtain

estimates on:

- the rate at which water moves through the system
- the rate at which carbon, nitrogen and phosphorus move with the water, and
- the importance of biogeochemical processes within the system.

The LOICZ procedure was applied to the entire basin of the Swan Canning estuary. The results and methods are discussed below.

Two-Layer Two-Basin System

The Swan Canning estuary behaves as a salt wedge estuary for much of the year. A two-layer LOICZ budget is thus used to model the system when stratified. To gain further information on the estuary it has been broken up into two basins: the upper basin and the lower basin, with the boundary at the Perth Causeway.

Water Balance

The LOICZ procedure assumes that the mass of water within the system stays constant over time:

$$\frac{dM}{dt} = \frac{dV}{dt} = 0 \quad (2)$$

where V is the volume of the system. There are no internal inputs or outputs of water, so that equation (1) simplifies to

$$0 = \sum inputs - \sum outputs \quad (3)$$

The generalised diagram used to represent the Swan Canning estuary is shown in Figure 2.31. Considering all the inputs and outputs to each box in the model, the water balance for the n th basin (where $n=1$ is the lower estuary and $n=2$ is the upper estuary) is given by the following:

Basin n surface layer

$$V_{Q^*n} + V_{Gn} + V_{entn} + V_{surfn+1} = V_{surfn} \quad (4)$$

where

$$V_{Q^*n} = V_Q + V_P - V_E \quad (5)$$

Basin n bottom layer

$$V_{deep(n-1)} - V_{deepn} = V_{entn} \quad (6)$$

Where the subscripts represent:

- Q - river inflow
- P - precipitation
- E - evaporation
- G - groundwater

$V_{ent\ n}$ represents the volume of water vertically entrained within the n th basin from the bottom layer to the surface layer; $V_{surf\ n}$ represents the volume of horizontal outflow from the n th surface layer and $V_{deep\ (n-1)}$ is the volume of horizontal inflow to the n th bottom layer from the $(n-1)$ th bottom layer. $V_{deep\ (n-1)}$ when $n=1$ represents the volume of inflow from the ocean, ie V_{ocean} . For the final basin ($n=2$) $V_{deep\ n} = V_{surf\ n+1} = 0$.

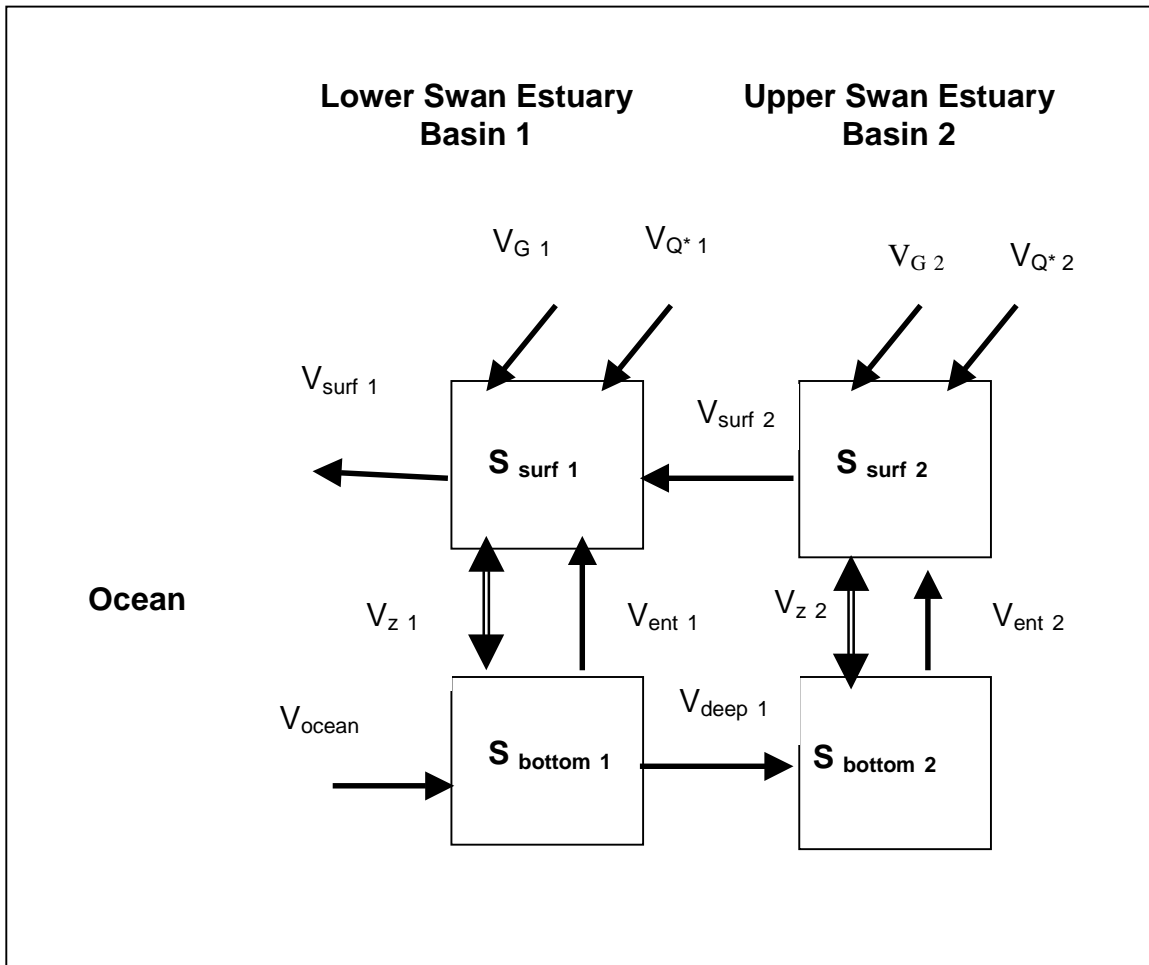

Figure 2.31 Generalised LOICZ model for the Swan Canning estuary.

Salt Balance

Salt is a conservative material, so equation (1) simplifies to equation (3), if it is assumed that the mass of salt in the system remains constant over the time-frame of interest. For a

steady state salt balance for basin n, the salt exiting the surface layer equals the salt input from the bottom layer. That is:

$$S_{surf\ n} V_{surf\ n} = S_{bottom\ (n-1)} V_{bottom\ (n-1)}. \quad (7)$$

Solving equations (4), (6) and (7) simultaneously gives the values for $V_{surf\ n}$, $V_{ent\ n}$ and $V_{deep\ n}$. To complete the salt balance an additional vertical mixing term V_{zn} is required to exchange surface and bottom water within a basin. V_{zn} is thus given by

$$V_{zn} = \frac{V_{deep\ (n-1)} (S_{bottom\ n-1} - S_{bottom\ n})}{(S_{bottom\ n} - S_{surface\ n})} \quad (8)$$

When a basin is well mixed the V_{zn} term tends to infinity and the two layer model reduces to a one layer model.

Nutrient Budgets

The conservation of mass equation, equation (1), can be applied to any material. For materials which undergo net transformations within the system, the Σ [sources-sinks] term is non-zero and represents the “non-conservative behaviour” of the system. Nutrients such as nitrogen and phosphorus are expected to display non-conservative behaviour. For a material Y, equation (1) can be for the nth basin as:

Surface Layer

$$\begin{aligned} \frac{dVY}{dt} = & Y_{Qn} V_{Qn} + Y_{Pn} V_{Pn} + Y_{Gn} V_{Gn} + V_{ent\ n} Y_{bottom\ n} + V_{zn} (Y_{bottom\ n} - Y_{surface\ n}) + V_{surf\ n+1} Y_{surface\ n+1} \\ & - V_{surf\ n} Y_{surface\ n} - Y_{En} V_{En} + \Delta Y_{surf\ n} \end{aligned} \quad (9)$$

Bottom Layer

$$\begin{aligned} \frac{dVY}{dt} = & -V_{ent\ n} Y_{bottom\ n} - V_{zn} (Y_{bottom\ n} - Y_{surface\ n}) + V_{deep\ n-1} Y_{bottom\ n-1} \\ & - V_{deep\ n} Y_{bottom\ n} + \Delta Y_{bottom\ n} \end{aligned} \quad (10)$$

where, $\Delta Y = Y$ [sources-sinks].

Application to Swan Canning Estuary

Due to the highly seasonal nature of the rainfall within the Swan Canning catchment, the LOICZ budget has been applied over distinct seasons. The seasons are summer (January-May), winter (June-August) and spring (September-December). Data for 1996 was used in the budgets, so that the results of the LOICZ budgets could be compared with the nutrient fluxes estimated by Fredericks *et al.* (1997). 1996 was a relatively wet year, with the total annual rainfall of 889 mm, exceeding the long-term average of 796 mm (Bureau of Meteorology data for Perth Airport).

Water Balance

Table 2.22 Volume data sources for the Swan Canning estuary.

<u>Quantity</u>	<u>Source</u>
V _{Q2}	1996 flow data for Walyunga site (SWN4) divided by 0.7. Walyunga contributes 70% of annual flow to the Swan Canning estuary (Frank Davies, pers. comm.).
V _{Q1}	Canning River inflow is approximately a factor of 15 smaller than inflows from the Swan River (Swan Canning Cleanup Programme Draft Action Plan) i.e., Flow data for Walyunga/15.
V _P	1996 rainfall data from Bureau of Meteorology, Perth Airport Station multiplied by surface area of estuary.
V _E	17-year monthly mean of pan evaporation from Bureau of Meteorology, WA converted to estuary evaporation by Perth pan to lake coefficient of 0.9 (Surface Hydrology Section, pers. comm.).
V _{G2}	Gnangara groundwater mound south and Cloverdale aquifer discharge to estuary. From Davidson (1995)
V _{G1}	Gnangara groundwater mound south and Jandakot groundwater mound discharge to estuary. From Davidson (1995).
V _{Inlet}	158 x 10 ⁶ m ³ (from Chari Pattiaratchi, pers. comm.).

Table 2.23 Average depth of surface layer (metres) in each season of 1996, Swan Canning estuary.

Season	Lower Estuary	Upper Estuary
<u>Summer</u>	Well mixed	1.5
Winter	2.5	5 (entire water column)
Spring	5	2

Salt Balance

For the Swan Canning estuary it can be assumed that $S_P \sim S_E \sim S_G \sim S_Q \sim 0$. S_Q was originally included in the calculation for salt balance but due to the low salinity of the inflowing water (1 ppt), it was insignificant and was removed from the equation. This leaves $S_{bottom\ n}$ and $S_{surf\ n}$ for both basins to assign. With each season, the depth of each layer changes. The average depth of the freshwater layer in the two basins was estimated from an overview of the vertical transect data. The average depths of each layer are

shown in Table 2.23. The average salinities of each layer and each basin were then calculated.

Nutrient Balances

The DIN and DIP concentrations required to evaluate equations (9) and (10) were taken from 1996 sampling data and the additional sources shown in Table 2.24. The individual layer concentrations were calculated as the average concentrations within that layer.

Table 2.24 Average nutrient values used in the mass balance, Swan Canning estuary.

Quantity	DIN (mmol m ⁻³)	DIP (mmol m ⁻³)	Source
Y _P ~ Y _E ~ 0	0	0	
Y _G	143.0	3.0	Appleyard (1992).
Y _{ocean}	0.4	0.06	South Metropolitan Coastal Waters Study 1996 & Perth Coastal Waters Study, Water Quality Data (Buckee <i>et al.</i> 1994).
Y _{Q summer}	33.4	1.9	Average of weekly data from all gauging stations in the Swan Canning catchment, 1996 data.
Y _{Q winter}	70.0	1.9	
Y _{Q spring}	32.6	1.6	

Results

The water and salt budgets for each season are shown in Figures 2.34-2.36. The key differences between each season are obvious: evaporation and groundwater were the dominant input terms in the surface layer of the upper basin over summer. The marine water input dominated the well-mixed lower basin, with most of the marine water exported back out to the ocean rather than transported to the upper estuary. The groundwater inputs were negligible over winter, with high freshwater inputs dominating the water balance. The water column in the upper estuary was completely flushed with freshwater, so that the upper estuary has been represented by a single box. The spring system represents a transition between the other two seasonal states.

The water exchange time within the entire Swan Canning estuary (the average length of time water stays in the system) for each season can be calculated by:

$$\tau = \frac{V_{Inlet}}{(V_{ocean} + \sum_n (V_{Q^*} + V_G))} \quad (11)$$

Table 2.25 gives the exchange times of the estuary for each season of 1996. The upper estuary is estimated to contribute 7% to the total estuary volume of 158 million m³.

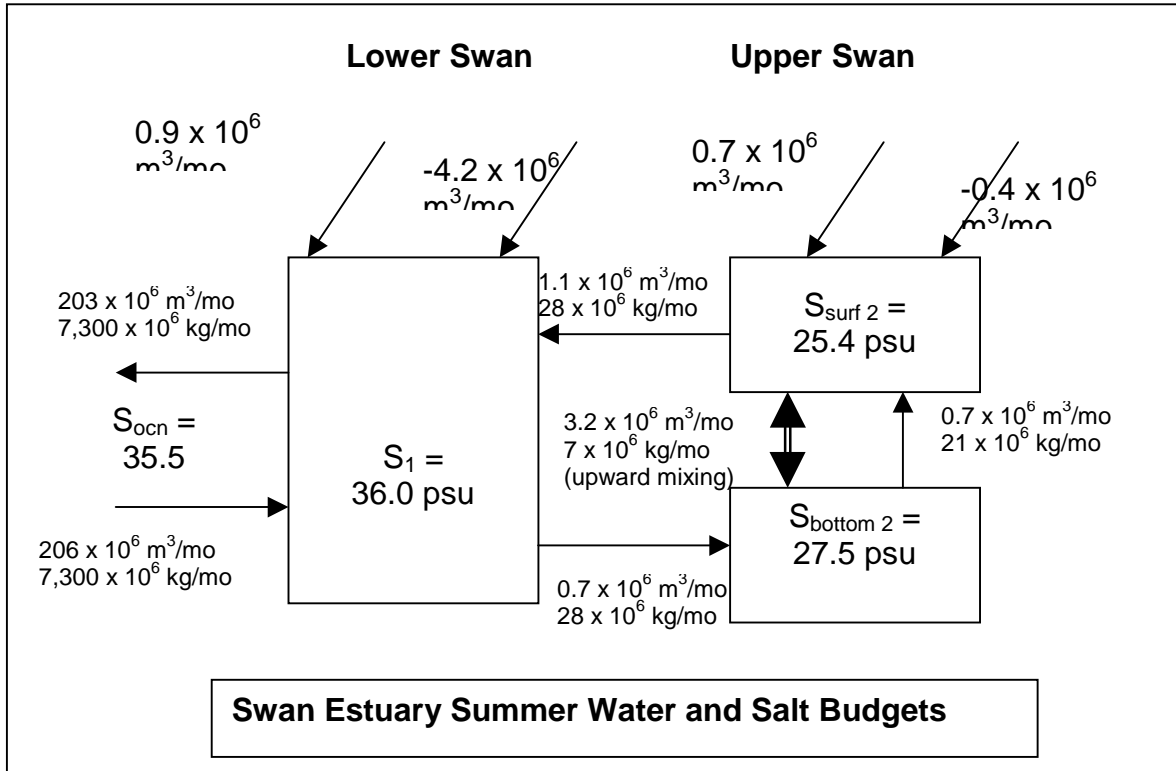

Figure 2.32 Summer water and salt budgets, Swan Canning estuary (see Figure 2.31 for details of arrows).

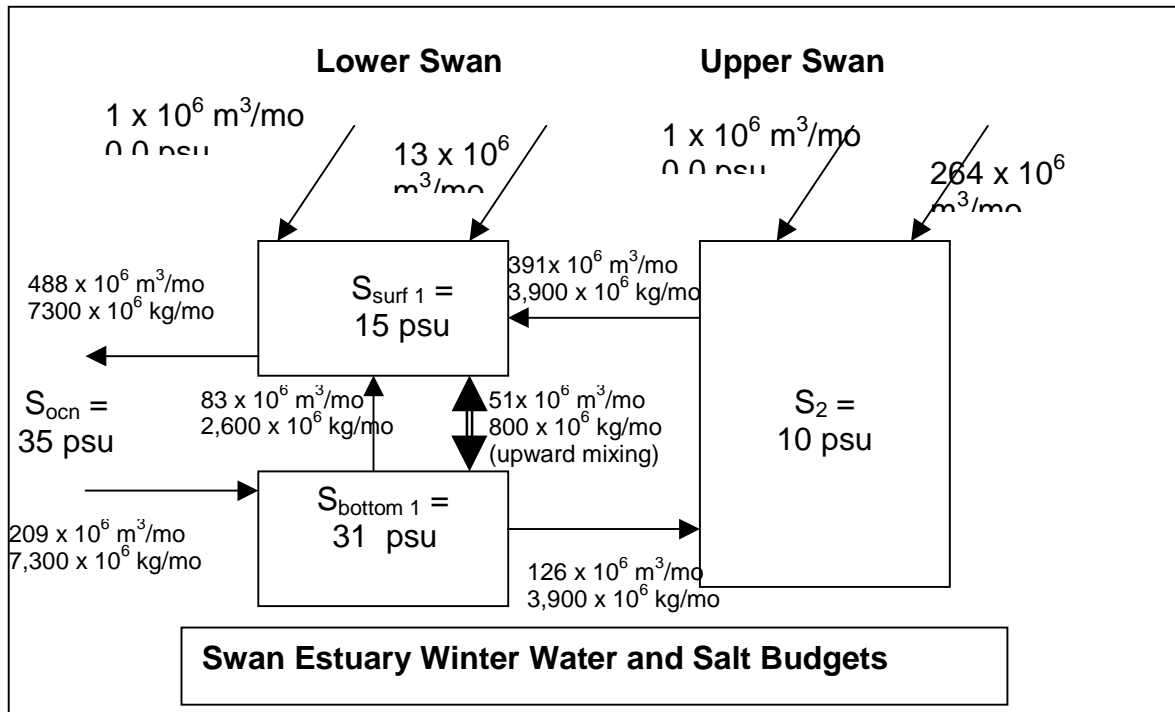

Figure 2.33 Winter water and salt budgets, Swan Canning estuary (see Figure 2.31 for details of arrows).

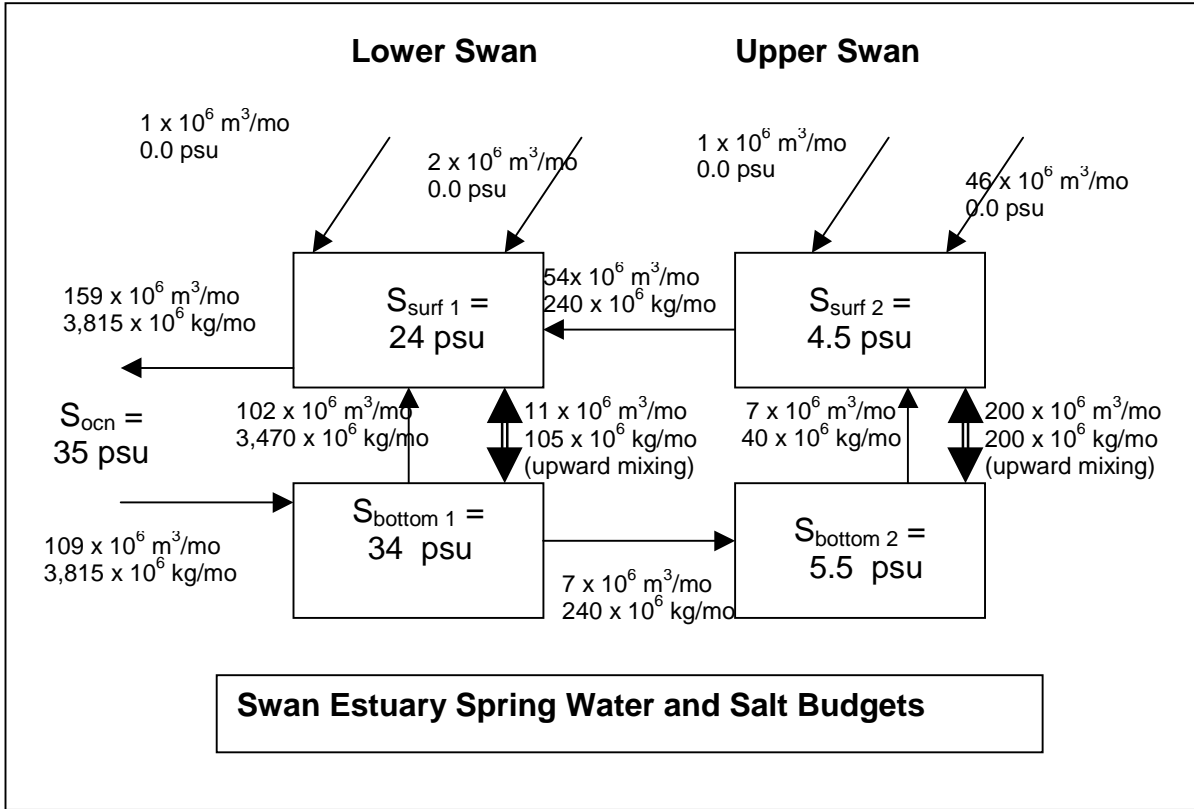

Figure 2.34 Spring water and salt budgets, Swan Canning estuary (see Figure 2.31 for details of arrows).

Table 2.25. Water exchange times for 1996, Swan Canning estuary.

Season	Exchange Time (days)		
	Lower Estuary 147 million m ³	Upper estuary 11 million m ³	Entire Estuary 158 million m ³
Summer	22	235	23
Winter	7	1	10
Spring	13	6	30
Annual			17

Nutrient Budgets

The nutrient budgets for each season are shown in Figures 2.35-2.37. Due to the considerable seasonal differences in the water budgets there are corresponding differences in the nutrient budgets.

In summer the groundwater term dominated the external inputs of both DIN and DIP. The DIP budget indicates that in the upper basin much of the DIP was taken up in the

surface layer (probably due to phytoplankton uptake or adsorption to particles and subsequent sedimentation). The bottom layer indicates regeneration of DIP that is then

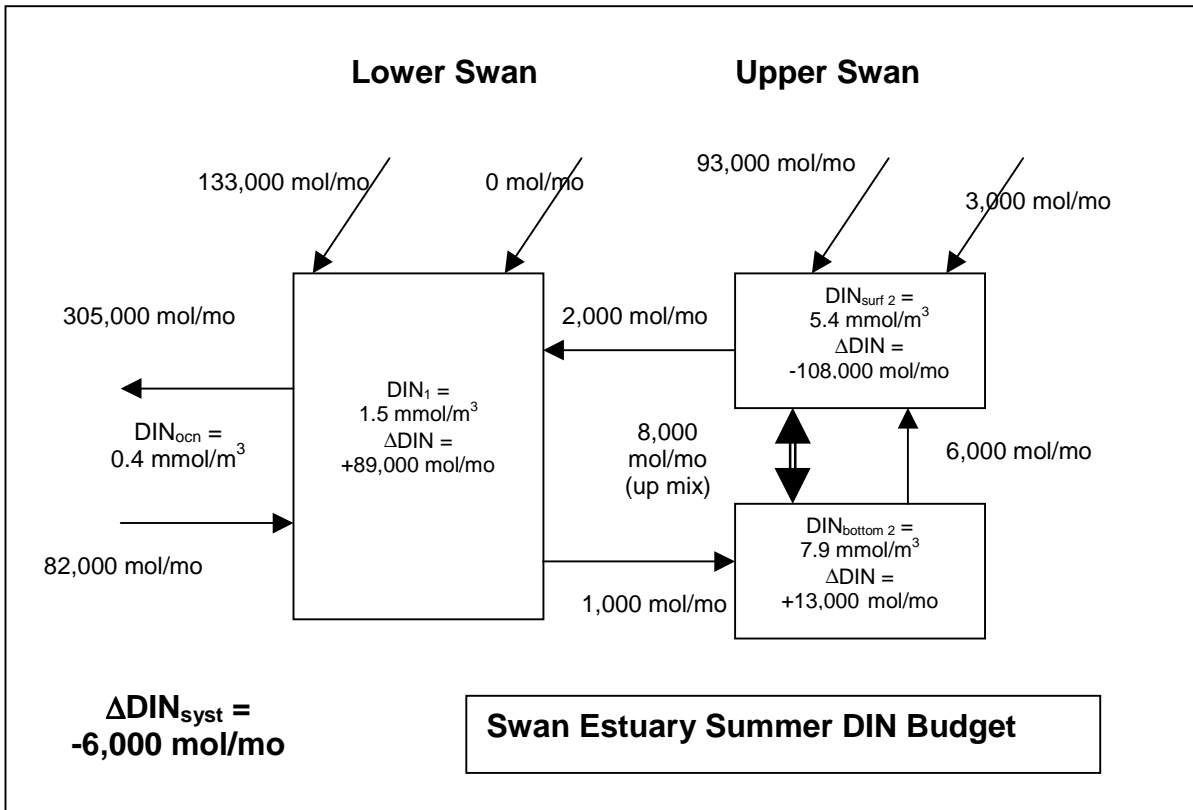
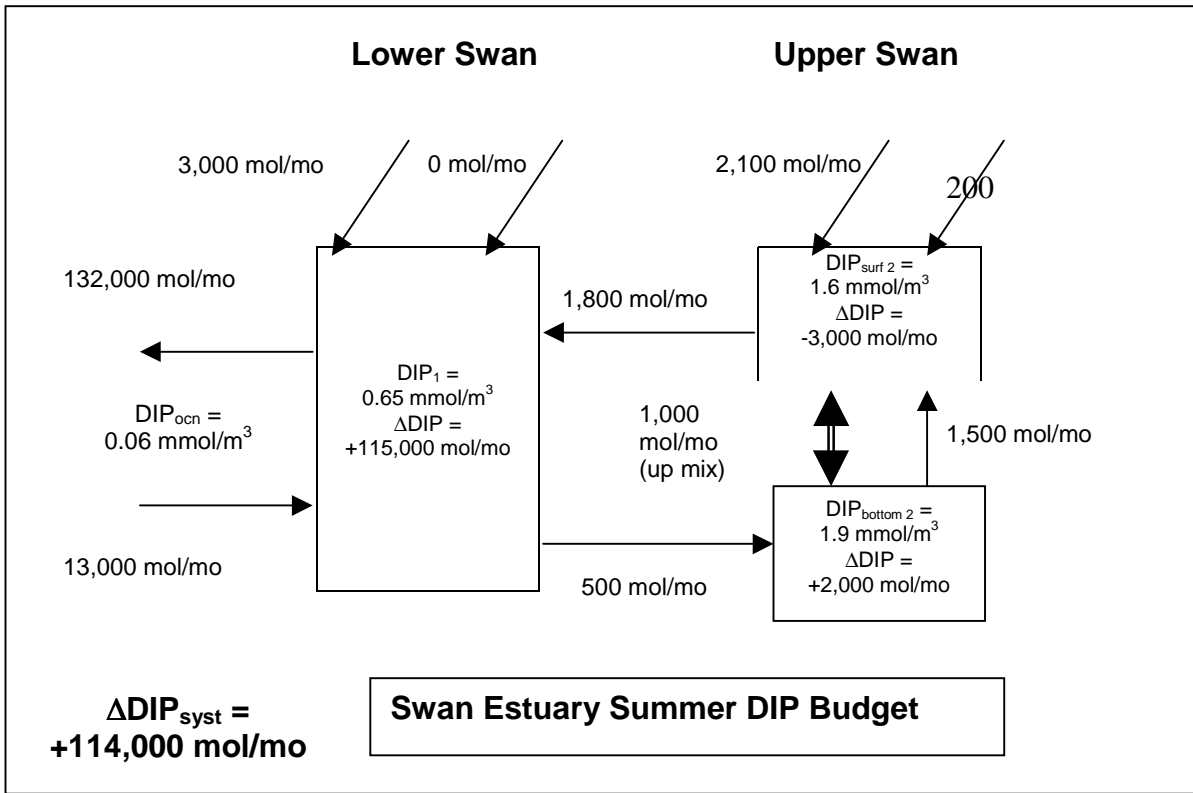

Figure 2.35 Summer DIP and DIN budgets, Swan Canning estuary (see Figure 2.31 for details of arrows).

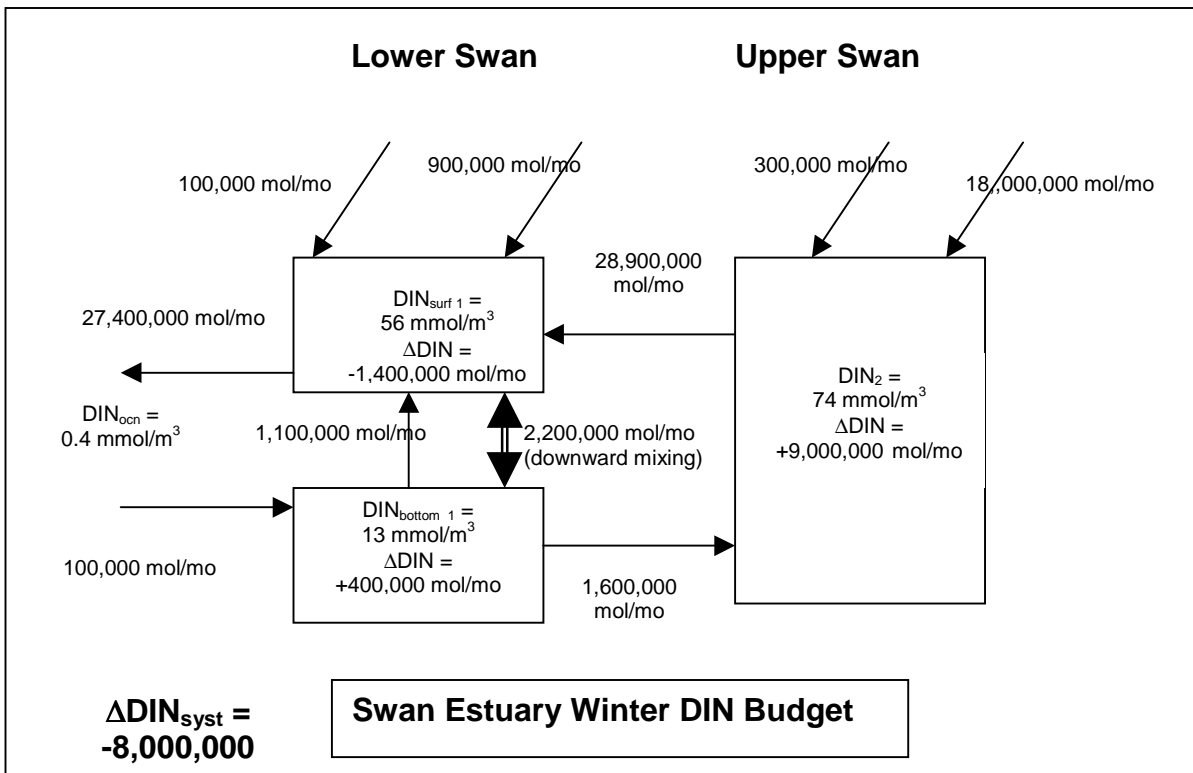
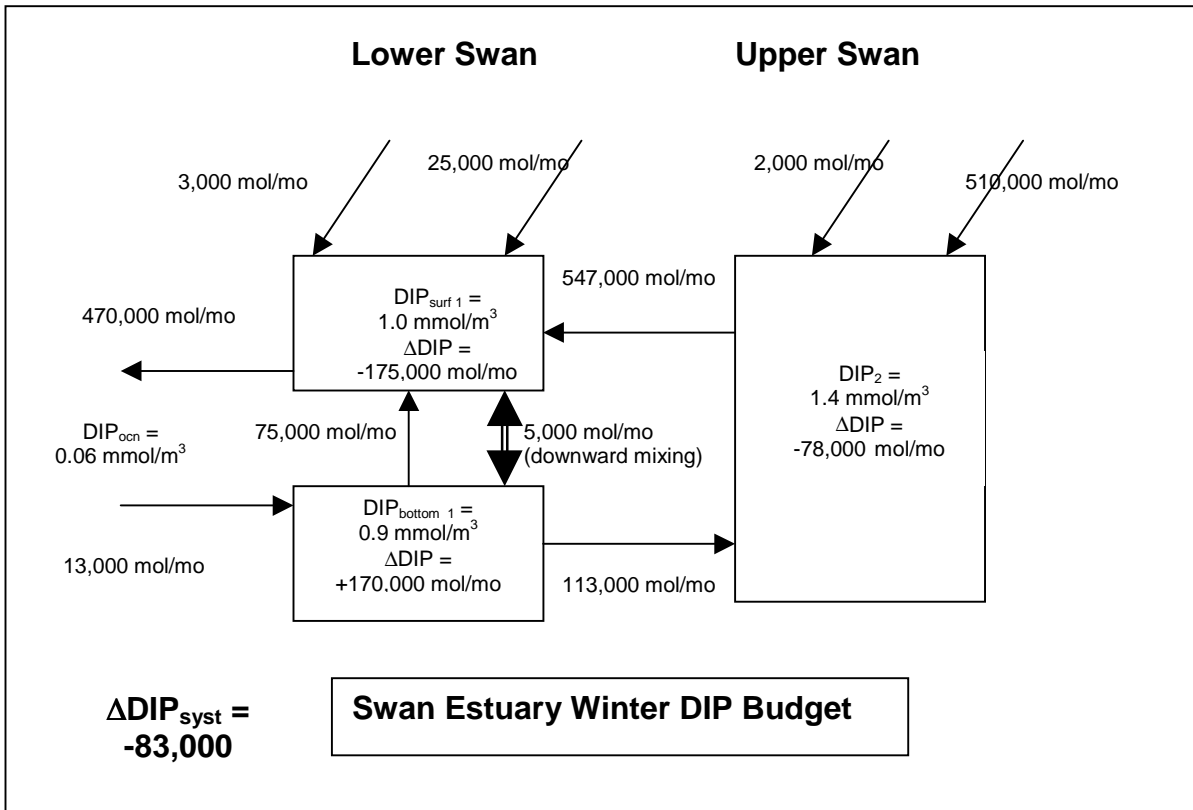

Figure 2.36 Winter DIP and DIN budgets, Swan Canning estuary (see Figure 2.31 for details of arrows).

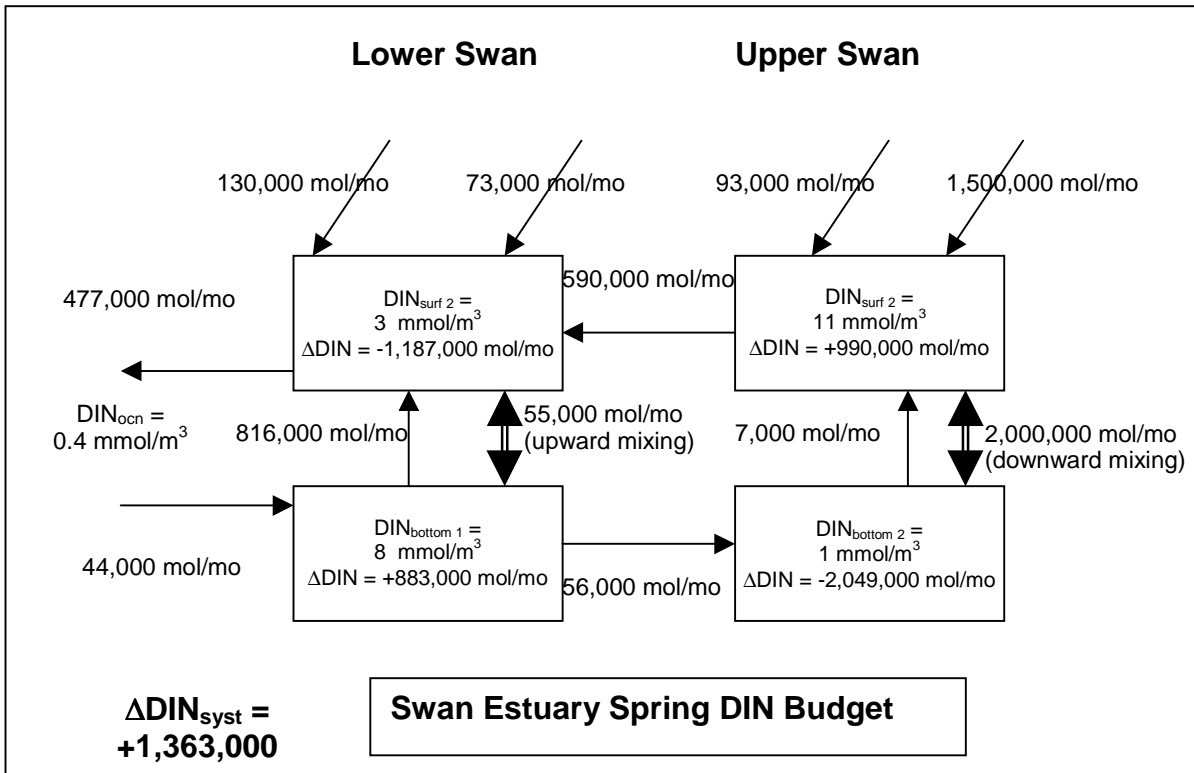
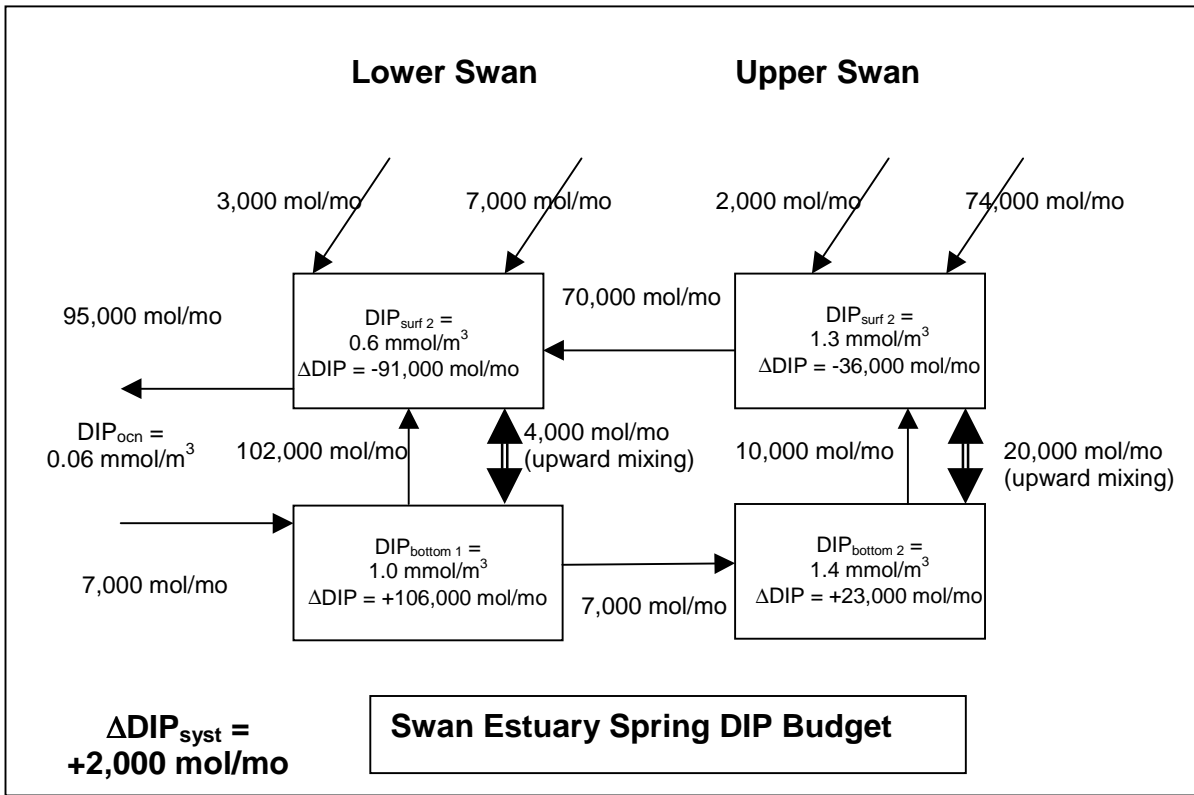

Figure 2.37 Spring DIP and DIN budgets, Swan Canning estuary (see Figure 2.31 for details of arrows).

transported into the surface layer. The upper basin overall was a small net sink of DIP. The DIP exported to the lower estuary from the upper basin was almost negligible compared to the large source of DIP generated within the lower estuary. Nutrient input from the ungauged urban catchment may contribute to this non-conservative source term. All of this DIP source term was exported from the estuary.

The summer DIN behaviour was similar to that of DIP. All of the groundwater DIN introduced into the upper estuary was retained within the surface layer of the upper basin. The bottom layer was a small source of DIN, which was exported to the upper layer. Again the lower estuary was a significant source of DIN, with the loadings from the source term and the groundwater inputs exported to the ocean.

The winter budgets have a much greater magnitude of nutrient fluxes, with large quantities of nutrients carried in with the freshwater inflows. The upper estuary acted as a sink for DIP and was a significant source of DIN. The surface waters of the lower estuary were also a net sink for DIP, while the bottom waters were a source of similar magnitude, so that the net non-conservative behaviour of P in the lower estuary was negligible. This probably represents net organic production in the surface layer followed by sedimentation and then P regeneration in the bottom sediments. The DIN species in the lower estuary showed a similar trend, with the surface waters acting as a sink and the bottom waters a source. For both species, export to the ocean was a significant mechanism for removal from the estuary.

The nutrient inputs from the catchment declined in spring, with reduced streamflow. There was uptake of DIP in the surface layer of both basins and release in the bottom layer. Most of the DIP in the upper estuary was exported in the surface layer to the lower estuary. More DIP was released in the bottom layer of the lower estuary than the total input from the catchment. Most of this DIP was entrained into the upper layer where it was either exported to the ocean or taken up within the surface layer. As in winter, the non-conservative behaviour of P in the lower estuary was balanced in the surface and bottom layers, so that overall the Δ DIP was negligible.

Nitrogen behaviour differed between winter and spring, with much of the nitrogen input from the catchment reaching the surface layer and subsequently mixed into the bottom layer of the upper estuary, where it was retained. The apparent production of DIN in the surface layer of the upper estuary may again be a result of nutrient input from the ungauged urban catchment. The surface layer of the lower estuary showed an uptake of DIN, while in the bottom layer there was a release of DIN. Export to the ocean was an important removal mechanism for DIP, but not for DIN, which was retained principally within the upper estuary.

A summary of the non-conservative terms in each season is given in Tables 2.26 and 2.27. The values are normalised by the area of each basin. The total area of the Swan Canning estuary is 33 km² with the lower estuary representing 91% of this area.

Table 2.26. Seasonal variation in non-conservative DIP fluxes ($\text{mmol m}^{-2} \text{d}^{-1}$), Swan Canning estuary.

Season	Lower Estuary			Upper Estuary		
	Surface	Bottom	Basin Total	Surface	Bottom	Basin Total
Summer	+0.13		+0.13	-0.03	+0.02	-0.01
Winter	-0.19	+0.19	+0.00	-0.93		-0.93
Spring	-0.10	+0.12	+0.02	-0.40	+0.26	-0.14
Annual Total ($\text{mmol m}^{-2} \text{yr}^{-1}$)			+17			-122

Table 2.27. Seasonal variation in non-conservative DIN fluxes ($\text{mmol m}^{-2} \text{d}^{-1}$), Swan Canning estuary.

Season	Lower Estuary			Upper Estuary		
	Surface	Bottom	Basin	Surface	Bottom	Basin
Summer	+0.1		+0.1	-1	+0	-1
Winter	-1.6	+0.4	-1.2	+100		+100
Spring	-1.3	+1.0	-0.3	+11	-23	-12
Annual Total ($\text{mmol m}^{-2} \text{yr}^{-1}$)			-119			+10 461

Stoichiometric Analysis

If it is assumed that DIP within the estuary undergoes negligible inorganic reactions and all the non-conservative behaviour is of biological origin, then the ΔDIP values in the Swan Canning estuary are a measure of the net production of organic matter in the system. The expected ΔDIN ($\Delta\text{DIN}_{\text{exp}}$) would be ΔDIP multiplied by the N:P ratio of the reacting organic matter. If phytoplankton is assumed to be the principal form of organic matter then, based on the Redfield ratio, $\Delta\text{DIN}_{\text{exp}} = 16 \Delta\text{DIP}$. Large differences between $\Delta\text{DIN}_{\text{obs}}$ and $\Delta\text{DIN}_{\text{exp}}$ are indicators of other processes that alter fixed nitrogen. As nitrogen fixation and denitrification are important processes in coastal systems, the differences are taken as a measure of net nitrogen fixation minus denitrification.

$$[\text{Nfix}-\text{Ndenit}] = \Delta\text{DIN}_{\text{obs}} - \Delta\text{DIN}_{\text{exp}} \quad (12)$$

The values of (*nfix-denit*) for each basin are shown in Table 2.28.

Table 2.28. Stoichiometric Analysis (*nfix-denit*) ($\text{mmol m}^{-2} \text{d}^{-1}$), Swan Canning estuary.

Season	Lower Estuary			Upper Estuary		
	Surface	Bottom	Basin	Surface	Bottom	Basin
Summer	-2.0		-2.0	-0.5	-0.3	-0.8
Winter	+1.4	-2.6	-1.2	+115		+115
Spring	+0.3	-0.9	-0.6	+17	-27	-10
Annual Total ($\text{mmol m}^{-2} \text{yr}^{-1}$)			-391			+12 413

The stoichiometric analysis indicates that in summer the entire estuary was net denitrifying, with the greatest magnitude of denitrification occurring in the lower estuary. When the estuary was stratified in winter and spring, there was net denitrification in the bottom waters of each basin and a smaller amount of nitrogen fixation in the surface waters. Overall, under stratified conditions, each basin was net denitrifying. In winter when the upper estuary was fully flushed with river runoff and the water column was well mixed, a large net nitrogen fixation was indicated. In general, the lower estuary (which occupies most of the system and which has salinities near oceanic) appears to generate (*nfix-denit*) values which seem reasonable, while the upper estuary does not.

Net Ecosystem Metabolism

The net ecosystem metabolism ($NEM = p-r$) is calculated as the negative of ΔDIP multiplied by the C:P ratio of the reacting organic matter. Assuming the bulk of the reacting organic matter is phytoplankton, the C:P ratio is 106:1. Thus:

$$(p-r) = -106(\Delta DIP) \quad (13)$$

For the Swan Canning estuary, ($p-r$) is shown in Table 2.29.

Table 2.29. Net ecosystem metabolism ($p-r$) ($\text{mmol m}^{-2} \text{d}^{-1}$), Swan Canning estuary.

Season	Lower Estuary			Upper Estuary		
	Surface	Bottom	Basin	Surface	Bottom	Basin
Summer	-14		-14	+3	-2	+1
Winter	+20	-20	0	+99		99
Spring	+11	-13	-3	+42	-28	+14
Annual Total ($\text{mmol m}^{-2} \text{yr}^{-1}$)			-1 800			+12 900

The lower estuary was apparently a net consumer of organic matter in summer. It is surprising that there was not a more significant production in the warm, light summer conditions. However this value for consumption may be inaccurate due to contributions of the ungauged drains to the positive ΔDIP term. In winter and spring the lower estuary was a net producer of organic matter in the surface waters throughout each season. The production was greatest in winter. The surface production was closely balanced by net consumption in the bottom waters, so that throughout the entire water column the ($p-r$) was close to zero.

In summer and spring, the upper estuary showed net production in the surface layer and net respiration in the bottom layer. The production in the surface layer exceeded respiration in the bottom layer, so that the upper estuary was a net producer of organic material. The production was highest in spring. The NEM in winter was the highest reported and indicated a production of organic matter. A higher production in winter compared with spring seems unlikely with the high turbidity and low temperature and light conditions in winter. It is likely that the NEM of the upper estuary in winter is incorrectly elevated by contributions to the ΔDIP term from inorganic and particle reactions and subsequent sedimentation.

General Discussion of Nonconservative Fluxes

Because of relatively short residence times in the upper estuary during winter and spring (Table 2.25), non-conservative flux calculations and stoichiometric balances are questionable. We consider the calculations based on the whole estuary, particularly those based on the annual balance, to be the most reliable.

Based on the total system mass balance (Figures 2.35-2.37), the total estuary ΔDIP is about $+4 \text{ mmol m}^{-2} \text{ yr}^{-1}$. This represents a very small portion of the terrigenous DIP input (about $77 \text{ mmol m}^{-2} \text{ yr}^{-1}$), and is effectively indistinguishable from zero. Uptake of DIP in the upper estuary during the summer is slightly more than offset by DIP released in the lower estuary during the summer, so that when integrated over an annual cycle the system is nearly conservative with respect to DIP. Also based on those figures, the total estuary ΔDIN is about $1\ 130 \text{ mmol m}^{-2} \text{ yr}^{-1}$. This represents DIN production equal to about 40% of the terrigenous DIN loading and is sufficient to suggest that there is a net DIN source within the system. The estuary total (*nfix-denit*) is calculated to be about $+1\ 070 \text{ mmol m}^{-2} \text{ yr}^{-1}$, suggesting net nitrogen fixation over an annual cycle. The calculated estuary total (*p-r*) is about $-400 \text{ mmol m}^{-2} \text{ yr}^{-1}$; that is, the system appears to be marginally net heterotrophic.

Comparisons with other work

The values derived in this LOICZ budget can be qualitatively compared to values experimentally measured by Fredericks *et al.* (1997) in a 1996 flux study of the Swan Canning estuary (see Appendix IVB). The numerical values cannot be directly compared, as the 1996 flux study provided instantaneous surface values, whereas this LOICZ budget has been averaged over an entire season with two depth layers. However, a qualitative comparison is valuable in assessing the LOICZ budget.

The summer survey of Fredericks *et al.* (1997) found a mid-estuary internal input of DIN. The surface layer of the upper estuary in the LOICZ model also indicates an input of DIN.

Fredericks *et al.* (1997) undertook two surveys over the time period used in the winter LOICZ budget. The survey in early winter was a low flow survey, while the second survey was a high flow survey. The nutrient behaviour under the two flow conditions was quite different and makes difficult comparison of the LOICZ winter budget. However, both winter surveys of Fredericks *et al.* (1997) showed that there was a net source of ammonium within the upper estuary. This agrees with the winter LOICZ budget that indicates a significant positive ΔDIN term.

The results of the 1996 flux study for the lower estuary indicated that under low flow conditions there was an uptake of DIN and a conservative behaviour under high flows. The LOICZ budget indicates a small uptake in the surface layer, but with most DIN exported to the ocean. The LOICZ result agrees well with the combined results of both surveys.

The LOICZ budget found a DIP uptake in the upper estuary, which does not agree with the 1996 flux study findings of conservative behaviour in both the low and high flow conditions. The LOICZ budget indicates that there was net removal of DIP in the surface waters of the lower estuary - under low flows there was input into the lower estuary and under high flows there was removal in the lowest section of the estuary and input in the middle reaches (part of the lower estuary LOICZ box). Due to the greater magnitude of the fluxes under the high flow situation it is likely that the high-flow scenario would have dominated the winter LOICZ budget. The two results are thus hard to compare due to the spatial variation in behaviour indicated by the flux study.

The spring survey of Fredericks *et al.* (1997) found an internal input of DIN (in particular ammonium) in the upper estuary and DIN removal in the lower basin. The surface boxes of the LOICZ model also indicate this to have been the case in spring. The flux study indicated that there was an internal input of DIP in the upper estuary and removal in the lower estuary. The LOICZ model differs in that it demonstrates a removal in the surface waters of both the lower and upper estuaries.

Further Work

This model could be improved by increasing the accuracy of some of the data. More accurate information could be obtained for groundwater volume inputs into the estuary and their concentrations of nutrients. Total volume of surface water entering the catchment could be improved by having a study undertaken on the contribution from the ungauged catchment and by updating the data from the gauged stations.

3. BUDGETS FOR NEW ZEALAND ESTUARINE SYSTEMS

3.1 HAURAKI GULF, NORTH ISLAND

John Zeldis and S.V. Smith

Study Area Description

The Hauraki Gulf (Site No. 21.; 175.00E, 36.50S) is a large temperate embayment on the north-eastern coast of the North Island, New Zealand (Figure 3.1; see Figure 1.1). The Gulf lies adjacent to a narrow continental shelf, bounded offshore by the south-eastward flowing East Auckland Current. New Zealand's largest city, Auckland, borders its south-western shoreline. New Zealand's largest commercial and recreational inshore fin fishery (for snapper), and important mariculture enterprises for mussels and oysters, are carried out in its coastal waters. Among the many recreational opportunities offered by the Gulf region are marine reserves of international significance and extensive yachting among its many islands, bays, and open waters. The significance of the region is underscored by its selection as the site of the year 2000 America's Cup yachting competition.

The Hauraki Gulf and adjacent shelf have been the subject of intensive physical and biological oceanographic studies over the last 5 years. Here, we develop a water, salt, and nutrient budget for the Hauraki Gulf-shelf system using data acquired in the NIWA

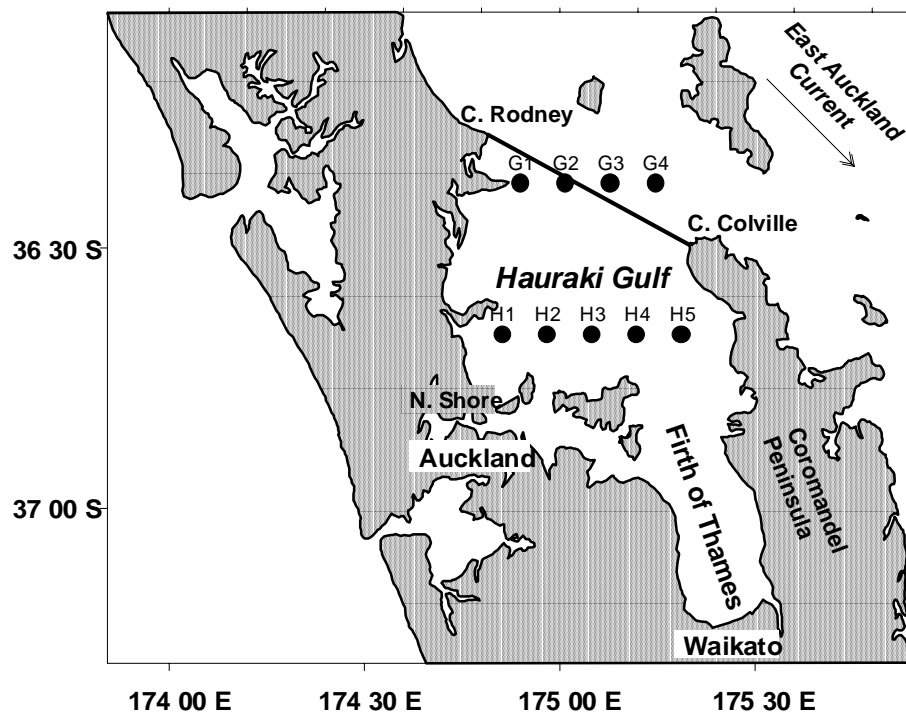

Figure 3.1 Hauraki Gulf, North Island New Zealand.

program 'Biological Effects of Cross-Shelf Exchange'. This operated four voyages in September, October, December and February (austral spring to summer) 1996-97 (Zeldis *et al.* 1998; Figure 3.1). Extensive data sets of dissolved inorganic nutrients (nitrate, ammonium, DIP, urea, silicate and DIC) were collected (Pickmere 1998), in combination with CTD data (Abraham 1998), moorings, remote sensing and studies of primary and secondary production (summarised in Zeldis *et al.* 1998). Physical modelling of the area has been carried out (Proctor and Greig 1989; Black *et al.* submitted). Thus, the data set represents a rich test bed for LOICZ-style modelling of the temperate continental margin.

System Description

The system is delimited by a line from Cape Rodney to Cape Colville (Figure 3.1) which divides the Gulf waters from the shelf waters offshore. In survey data, strong gradients of salinity and chlorophyll often are seen associated with this boundary, reflecting the propensity of the residual southeasterly shelf circulation to 'bypass' the Hauraki Gulf entrance. The H-line stations (Figure 3.1) are used to represent the 'system' or 'Gulf' and the G-line stations are used to represent the 'shelf'. Salinity and nutrient data from these transects were depth-averaged at each station, and were averaged for three voyages; DIP data from the September 1996 voyage were lost due to a laboratory error, and data from that voyage were not used.

The Gulf system has a surface area of 5800 km², and a volume of 94 x 10⁹ m³ (U. Shankar, NIWA, personal communication). While the Gulf has a maximum depth of 50 m, the average depth is about 16 m, with extensive shallow areas in the Firth of Thames and other inner harbour reaches.

Freshwater and freshwater nutrient sources

Extensive climatological and water resource data are available for the Hauraki Gulf region, through various municipal, regional and governmental agencies. The total riverine inflow to the inner Gulf is about 100 cumecs, predominantly from the Waikato dairying areas, and native forest regions of the Coromandel Peninsula (A. McKerchar, NIWA, personal communication). Both regions drain to the Firth of Thames in the southeastern Gulf (Figure 3.1). The great majority of dissolved inorganic P and N from rivers is derived from the pastoral catchments (Environment Waikato 1998 a,b; B. Vant, Environment Waikato, personal communication). Groundwater is a relatively small contributor to inflow, with the landform composed largely of relatively impermeable sandstones (A. Smail, Auckland Regional Council, personal communication).

The net balance of precipitation and evaporation switches from positive to negative between spring and summer, with rainfall decreasing by two thirds and evaporation increasing by a third between the seasons (S. Brown, NIWA, personal communication). Wet and dry atmospheric deposition of P and N are likely to be small factors in this relatively clean air region.

There are significant discharges of treated sewage effluent, predominantly at North Shore, Auckland (Figure 3.1) and other smaller discharges along the west coast of the

Gulf. Although the water volume of sewage is small relative to other freshwater inputs, dissolved P and N are highly concentrated in the effluent (M. Shipton, North Shore Regional Council, personal communication) so that nutrient flux from this source is significant relative to other freshwater nutrient sources.

Saltwater and marine nutrient sources

In winter and spring, the shelf region bordering the Hauraki Gulf regularly receives low salinity water from the continental slope, forced onshore by prevailing westerly and north-westerly winds which are favourable to upwellings (Sharples and Greig 1998, Zeldis *et al.* 1998). Later in summer, the shelf typically receives high salinity surface water from the East Auckland Current, driven onshore by south-easterly winds (Sharples 1997, Zeldis *et al.* 1998). Thus, although the net input of freshwater to the Gulf system decreases considerably between spring and summer, a reasonably strong increasing salinity gradient persists on-offshore, over this period. This was the case during the entire period (October 1996 - February 1997) here, when average salinities were 34.9 and 35.2 psu in the Gulf and shelf respectively.

Dissolved inorganic nutrients can be transported well into the inner Gulf by the tidal, current and wind-forced residual circulation (Sharples 1997; Zeldis *et al.* 1998). Such transport occurred during the October and December (spring and early summer) voyages, when relatively high levels of DIP and especially DIN were introduced. By late summer, low nitrate (but higher ammonium) conditions prevailed in the Gulf.

Other

There is considerable variability in the Gulf region between spring and summer for parameter values important to the budgeting procedure including precipitation/evaporation and marine nutrient loading. Furthermore, the Gulf hydrographic system moves from a relatively unstratified water column to one with relatively strong differences in bottom and surface density between spring and summer. The interplay between seasonal changes in freshwater input and stratification intensity could be expected to alter the rates of estuarine circulation, and hence residence time, between seasons. While variation in these values could be expected to yield variable results when modelled over the short term (e.g., monthly), for the present exercise a relatively unsophisticated time-averaged and non-vertically stratified model approach is taken. It is assumed that the budget describes the average of spring/summer water and nutrient dynamics.

We assumed that the particulate Redfield ratio was 106:16:1, because production in the system is largely plankton based. The budgetary analysis was performed using the LOICZ Guidelines (Gordon *et al.* 1996), and is presented in Figures 3.2 and 3.3.

Water and Salt Budgets

For the October-February 1996-97 Hauraki Gulf water budget (Figure 3.2), precipitation, evaporation, and river flow data were used from the period June to January 1996-97, assuming that the estuarine circulation would involve freshwater input from the previous

few months. It was assumed that system volume (V_I) remained constant over the model period (i.e., $dV_I/dt=0$), such that the residual flow V_R was:

$$V_R = -V_Q - V_P - V_E \quad (1)$$

where V subscripts R , Q , P , and E identify volumes of total residual flow, river runoff, precipitation, and evaporation. Recall that V_E is negative and note that the small terms for groundwater and sewage are neglected. Because V_R is negative, residual flow is out of the Gulf.

Again neglecting the small terms and assuming the salinity of precipitation, runoff and evaporated water to be zero, the steady-state balance of salt between the Gulf (V_{syst}) and Shelf (V_{ocn}) can be defined by:

$$0 = V_R S_R + V_X (S_{ocn} - S_{syst}) \quad (2)$$

where the salinity of the residual flow is estimated as the average of the system and ocean salinities and V_X is defined as the mixing between system and ocean waters. Rearrangement of this expression allows calculation of the exchange flow, V_X .

The residence time of water in the Gulf (with volume = V_{syst}) is calculated as:

$$\tau = \frac{V_{syst}}{(V_X + |V_R|)} \quad (3)$$

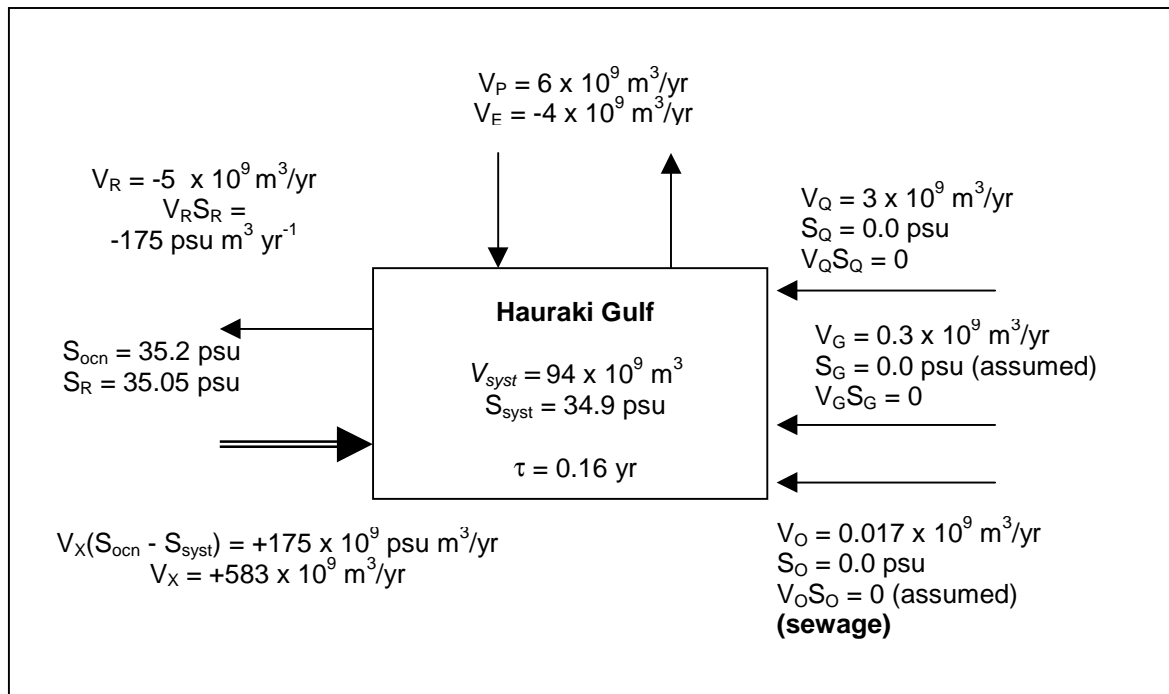

Figure 3.2 Steady state water and salt budgets, Hauraki Gulf.

Budgets of non-conservative materials (P and N)

Dissolved inorganic nutrients which behave non-conservatively may be assumed to be transported into and out of the system by the same residual flows and mixing processes described for water and salt. These terms are represented by the inputs and outputs

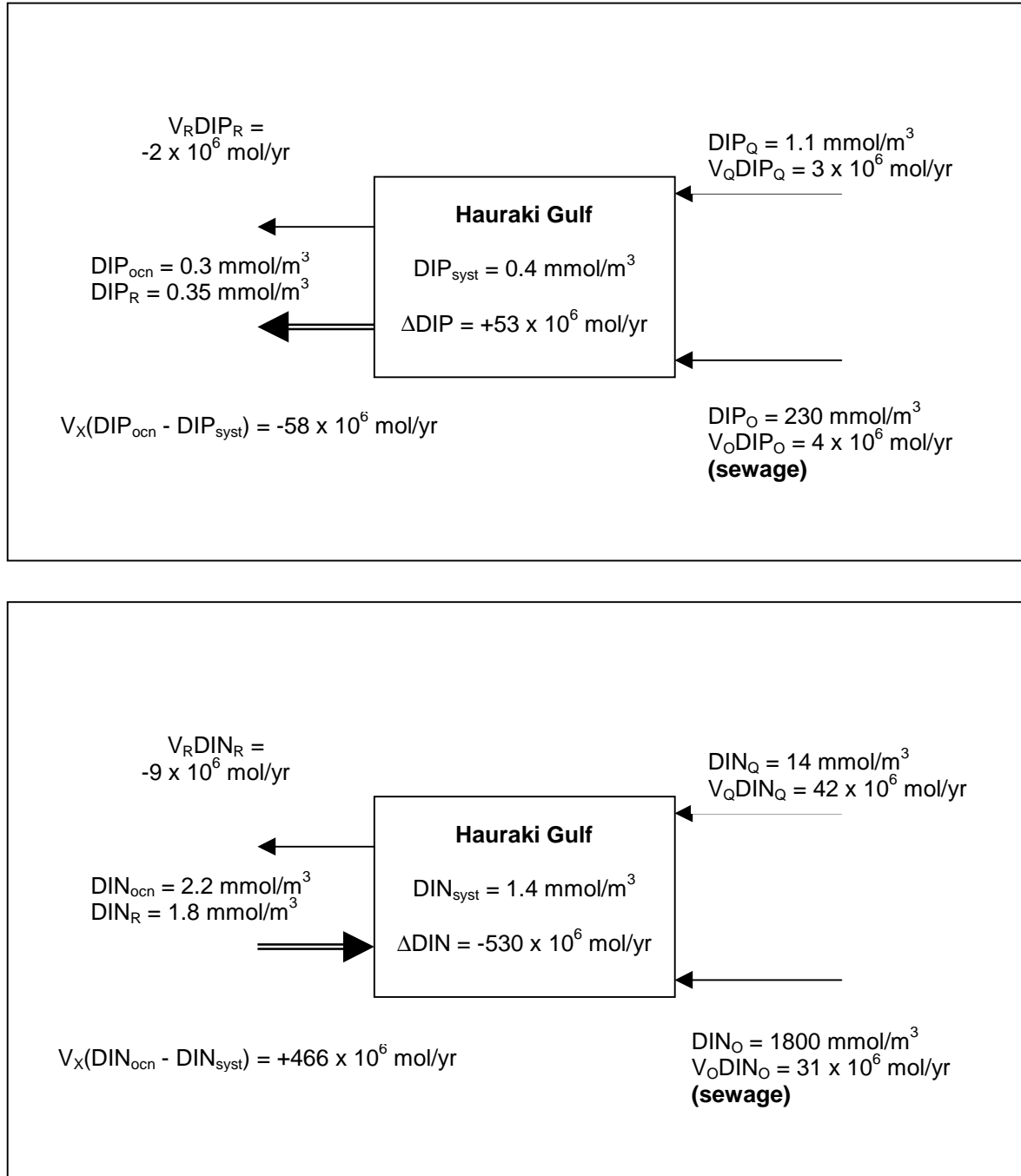

Figure 3.3 Steady state DIP and DIN budgets, Hauraki Gulf.

functions shown in equation (4). However, the flux of biogeochemically reactive materials includes an additional term, ΔY , to account for the net non-conservative behaviour (release - uptake) within the system:

$$\frac{VdY}{dt} = 0 = \sum V_{in} Y_{in} - \sum V_{out} Y_{out} + \Delta Y \quad (4)$$

For the non-conservative flux of DIP (Δ DIP) in the Hauraki Gulf (Figure 3.3), this expression was evaluated as the sum of riverine, other (sewage), residual and exchange flows. Wet and dry atmospheric deposition and groundwater sources for DIP were assumed negligible. The non-conservative fluxes of DOP (not measured) were assumed to be small. The positive value of Δ DIP indicates that the system has an internal DIP source, i.e., internal system reactions are generating DIP over particulate organic P, suggesting that it is a net respiring, oxidative system. Thus, the difference between production and respiration ($p-r$) for the system is apparently negative. The production of DIP on an areal basis is about $14 \text{ mmole DIP m}^{-2} \text{ y}^{-1}$. If the Redfield relationship of C:P of 106:1 is assumed, the system is producing about $1.5 \text{ mole C m}^{-2} \text{ y}^{-1}$.

For the non-conservative flux of DIN (Δ DIN), similar calculations apply as for Δ DIP (Figure 3.3). Again, atmospheric and groundwater sources of N were considered negligible. The negative value of Δ DIN indicated that the Gulf system was a net sink for DIN. The observed value of Δ DIN_{obs} is equivalent to about $-140 \text{ mmol m}^{-2} \text{ yr}^{-1}$. If DIN were released in a Redfield Ratio (16:1) with respect to DIP, the expected DIN flux (Δ DIN_{exp}) would be $+224 \text{ mmol m}^{-2} \text{ yr}^{-1}$. The discrepancy ($-364 \text{ mmol m}^{-2} \text{ yr}^{-1}$) is interpreted according to the LOICZ Guidelines as a measure of (*nfix-denit*).

Conclusions

The average spring-summer water residence time for the Gulf was estimated at about 0.16 yr (about 58 days). For the nutrient budgets, the positive value for Δ DIP showed that the system was a net exporter of dissolved inorganic phosphorus, suggesting that the system oxidises more organic matter than it produces, with primary production minus respiration ($p-r$) of about $-4 \text{ mmole C m}^{-2} \text{ d}^{-1}$. Relative to a likely value for net primary production in the Gulf on the order of $100 \text{ mmole C m}^{-2} \text{ d}^{-1}$, the system is essentially balanced between production and respiration. The Gulf appears to be a net sink for DIN, suggesting that denitrification is occurring within the system, the difference between observed and expected Δ DIN indicating a denitrification rate of about $1 \text{ mmole N m}^{-2} \text{ d}^{-1}$. Present studies in the Hauraki Gulf will provide direct measurements of primary production and denitrification, to compare with these budget estimates.

Interesting comparisons are possible between the N and P fluxes from sewage, riverine and oceanic sources, using these budget calculations for the Hauraki Gulf. The flux of DIN from all sewage outfalls in the Gulf was about two thirds that of DIN flux from rivers, and about 7% that of the exchange flux from oceanic mixing, averaged over the whole Gulf and across the spring - summer period. For DIP, sewage flux was about equal to riverine flux and about 15% that of oceanic mixing. Thus, the dissolved nutrient fluxes from sewage are similar to the fluxes from farming in the catchment, but are

substantially less than nutrient exchange fluxes with the open ocean. Of course, this analysis does not inform us about the more localised effects sewage and farm-derived nutrient inputs may have, but it does provide a perspective on the relative sizes of the factors affecting nutrient dynamics of the Hauraki Gulf.

3.2 MANUKAU HARBOUR, NORTH ISLAND V. Dupra

Study Area Description

Manukau Harbour (Site No. 22.; 174°E, 37°S,) is a large (~370 km²) and shallow (mean depth ~ 6 m) embayment located on the west coast of the North Island, New Zealand (Figure 3.4). Freshwater influence is low so that the average salinity of the Harbour is close to that of the nearby coastal waters. The water column is vertically well-mixed due to the strong tidal circulation (Heath *et al.* 1977). The Harbour is dissected into three main channel systems from the mouth, spreading to the north-east, east and south. These channel systems are designated "Northern Channels", "Papakura Channel" and "Waiuku Channel" in Vant and Williams (1992). There is very limited exchange across the shallow areas shown in Figure 3.4 and between the channels.

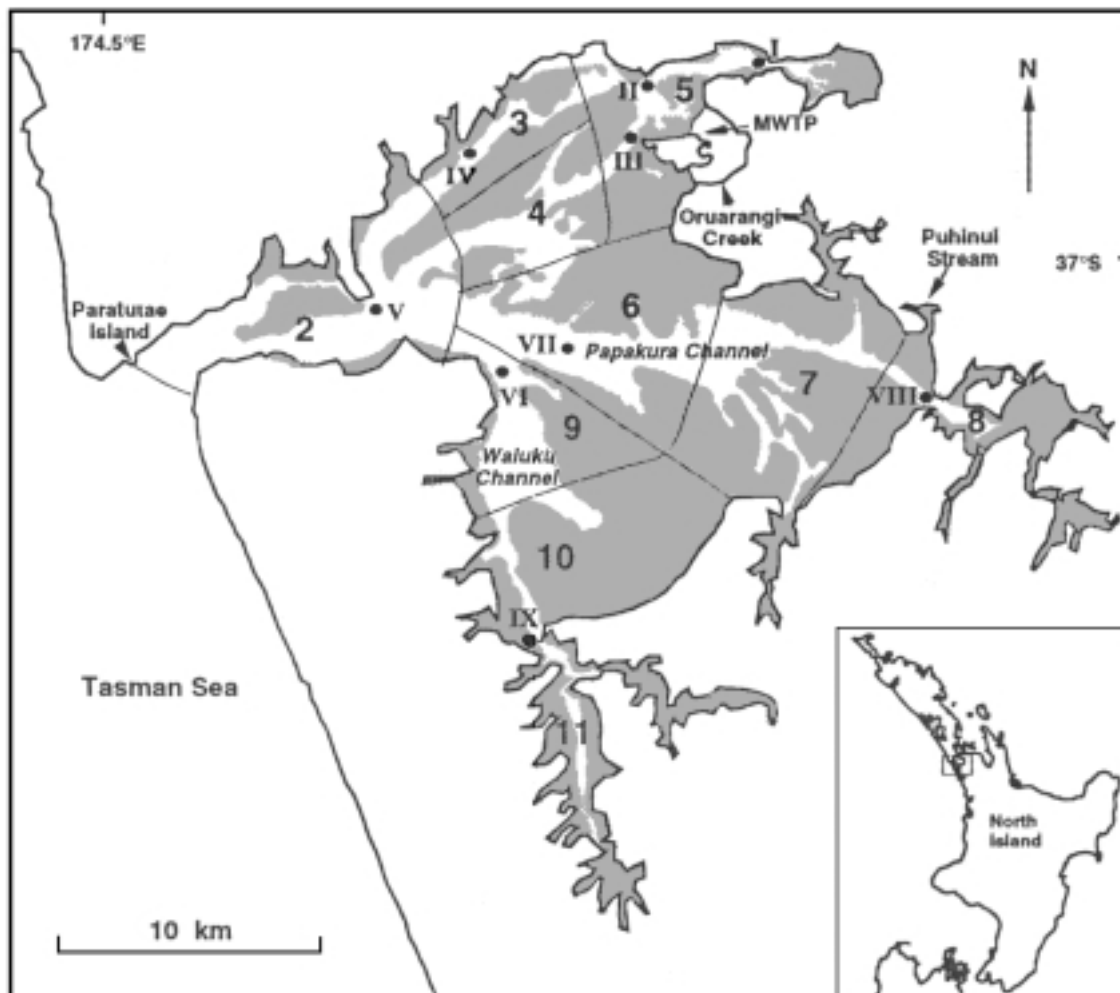

4. BUDGETS FOR PAPUA NEW GUINEA ESTUARINE SYSTEMS

4.1 FLY RIVER

B. N. Opdyke, A. Suzuki, Peter Davies and G. Brunskill

Study Area Description

The Fly River (Site No.1) is one of a number of large rivers that drains the wet tropical interior of Papua New Guinea. It drains a basin that is 75 000 km² and discharges into the Gulf of Papua at 143.30E, 8.30S (Figure 4.1; see Figure 1.1). The water-covered area of the Fly River Delta is approximately 500 km². Flow down the Fly River generally varies from 3 000 to 7 000 m³ sec⁻¹ during a given year. However, 1997 was an El Nino year, with a significant drought in the Fly River catchment. We estimate that flows were reduced to approximately 1 000 m³ sec⁻¹ during the study period.

The Fly River catchment has been the focus of much interest since the opening of the giant Ok Tedi mine, which is located in the headwaters of the river. Sediment load down the rivers of PNG is high but sediment from the Ok Tedi mine has made the sediment load on the Fly River quite extreme and the environmental impact is still being assessed. Human population in the Fly delta region is sparse.

Water and nutrient data were collected during the TROPICS cruise 5A on board the *R/V Harry Messel* in 1997.

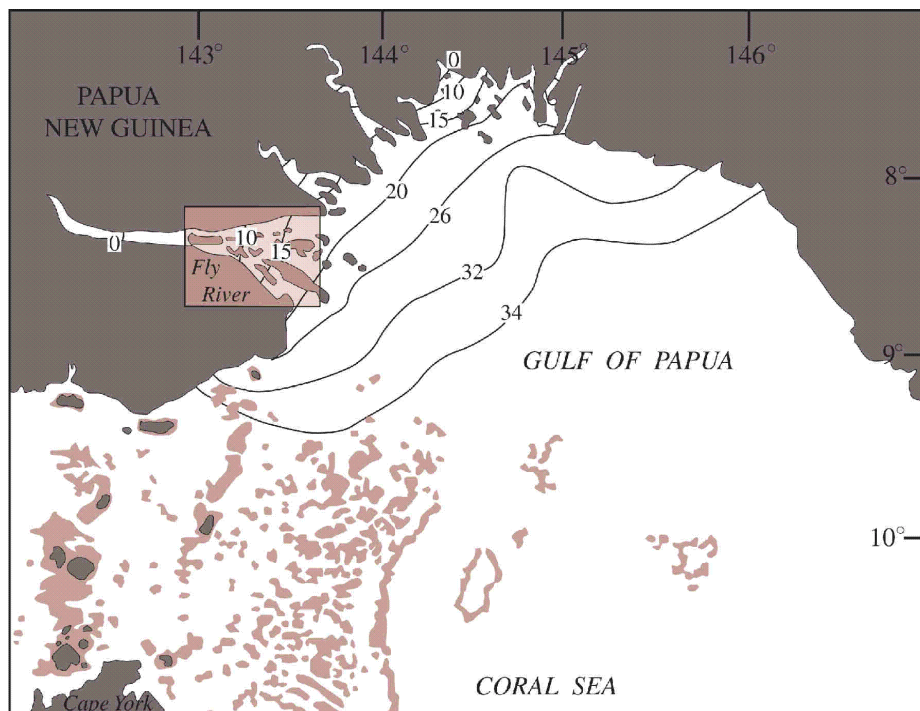

Figure 4.1 Fly River estuary and the Gulf of Papua.

Water and Salt Budgets

This is a system obviously dominated by the large flow of the Fly River. Both precipitation and evaporation are over a $1\,000\text{ mm yr}^{-1}$, constitute a small term in this equation and should largely offset each other. The “horn” of the delta is where most of the mixing takes place between freshwater and seawater, and hence an area of much dynamic sedimentation and organic carbon deposition. The delta is mesotidal, and the surface area of water within the horn is approximately 500 km^2 . Average water depth within this area is approximately 5 m . This yields a volume of $2.5 \times 10^9\text{ m}^3$. Water and salt budgets are illustrated in Figure 4.2. Within the box defined in Figure 4.1, the average salinity of water arriving at the estuary is 0 psu ; the average within the estuary is 11 psu , and the average on the shelf is 28 psu (Figure 4.2). The water exchange time for the drought-plagued Fly River estuary is 13 days . Typically, the exchange time would be a third of this or less.

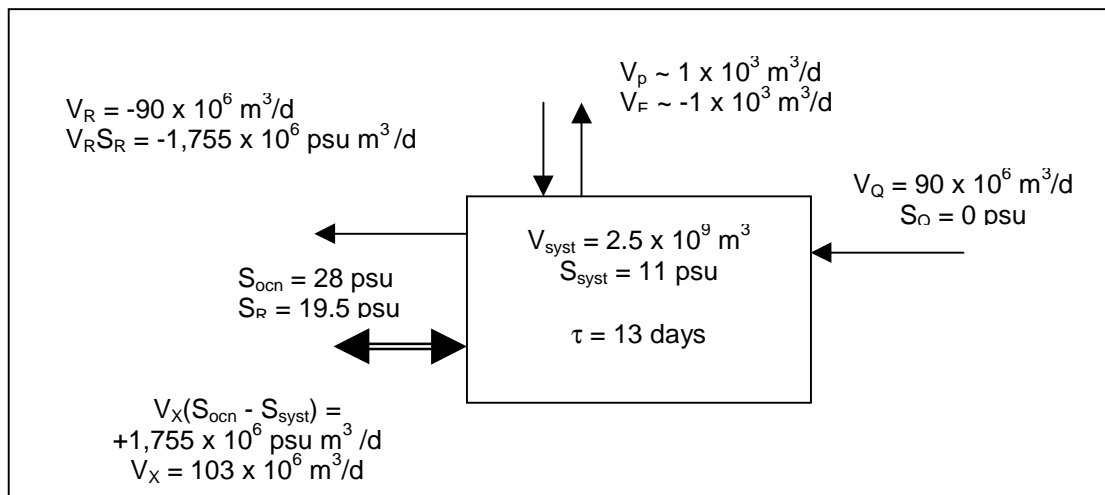

Figure 4.2 Water and salt budgets during the 1997 drought, Fly River estuary.

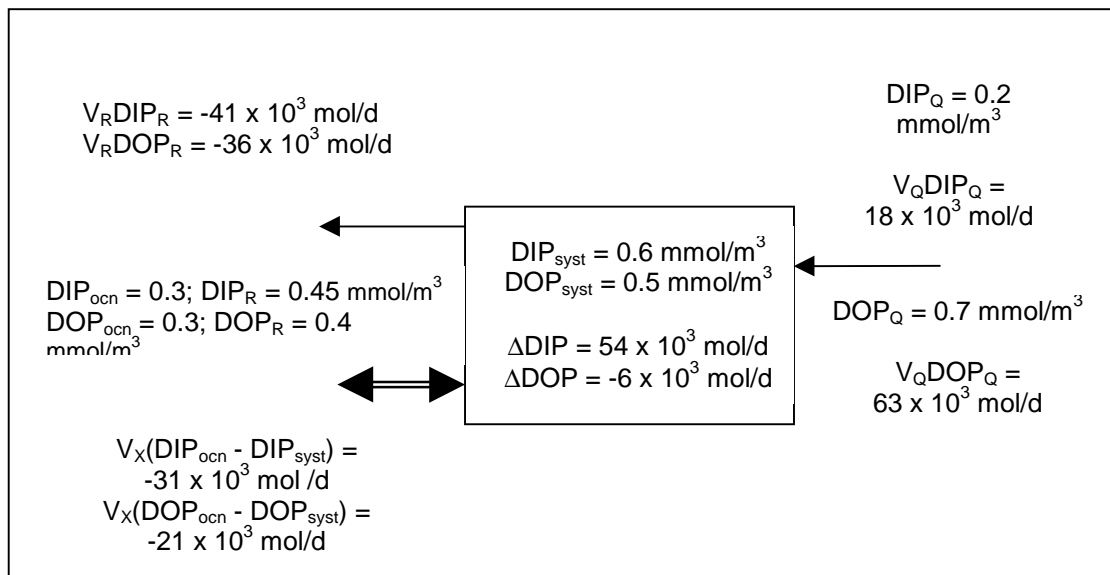

Figure 4.3 DIP and DOP budgets during the 1997 drought, Fly River estuary.

Budgets of Non-conservative Materials

P Balance

DIP concentration in the Fly River estuary is slightly elevated in comparison to the river and open shelf. ΔDIP is positive ($+54 \times 10^3 \text{ mol d}^{-1}$ or $0.1 \text{ mmol m}^{-2} \text{ d}^{-1}$) (Figure 4.3). ΔDOP , on the other hand, is near 0 ($-6 \times 10^3 \text{ mol d}^{-1}$ or $-0.01 \text{ mmol m}^{-2} \text{ d}^{-1}$).

N Balance

Net non-conservative DIN flux is low in this system, with $\Delta\text{DIN} = -82 \times 10^3 \text{ mol d}^{-1}$ or $-0.26 \text{ mmol m}^{-2} \text{ d}^{-1}$ (Figure 4.4). There is, however, DON production in the system: $\Delta\text{DON} = +560 \times 10^3 \text{ mol d}^{-1}$ or $+1.1 \text{ mmol m}^{-2} \text{ d}^{-1}$.

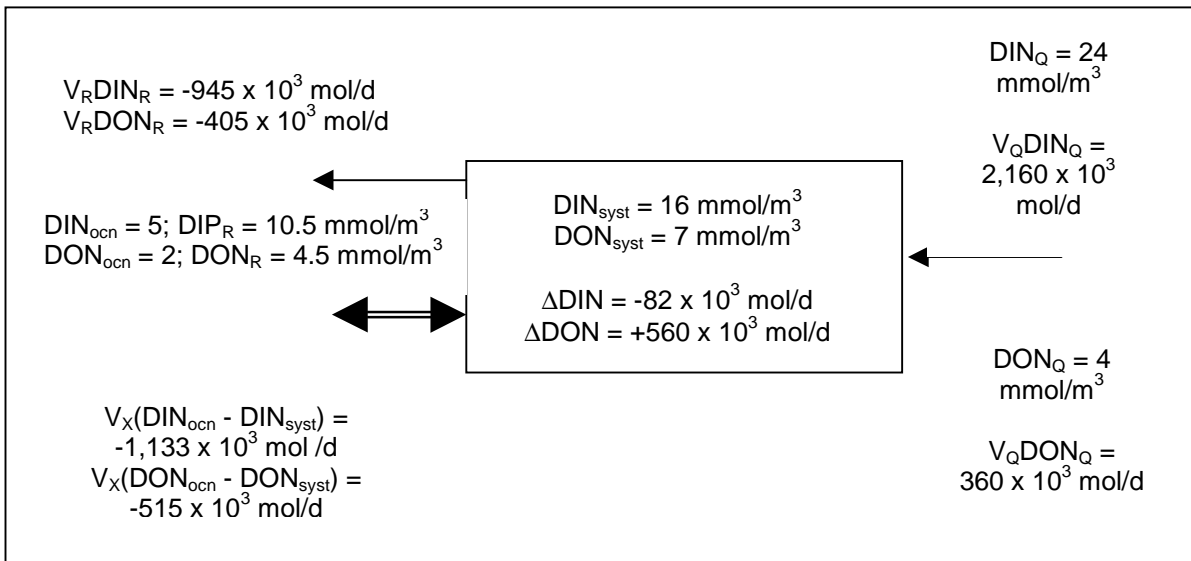

Figure 4.4 DIN and DON budgets during the 1997 drought, Fly River estuary.

Stoichiometric Calculations of Aspects of Net System Metabolism

Net nitrogen fixation minus denitrification (*nfix-denit*) is calculated as the difference between observed and expected $\Delta\text{DIN} + \Delta\text{DON}$. Expected ΔN is ΔP multiplied by the N:P ratio of the reacting particulate organic matter. In this case we have employed the Redfield ratio for marine plankton (16:1).

$$(\text{nfix-denit}) = 478 \times 10^3 - 16 \times (+48 \times 10^3) = -290 \times 10^3 \text{ mol N d}^{-1} \text{ } (-0.6 \text{ mmol m}^{-2} \text{ d}^{-1})$$

Therefore we see apparent slight net denitrification. For most systems, organic N and P calculations are not available. It is therefore instructive to compare these results with calculations based strictly on the observed and expected ΔDIN . In that case, (*nfix-denit*) = $-946 \times 10^3 \text{ mol d}^{-1}$, or about $-1.9 \text{ mmol m}^{-2} \text{ d}^{-1}$. Thus, the magnitude, but not the qualitative conclusion, is changed.

Net ecosystem metabolism ($NEM = p-r$) can also be estimated in a similar way, as the negative of the non-conservative DIP flux multiplied by the C:P ratio of the reacting

organic matter. If the organic matter is plankton, then the particulate C:P Redfield ratio is 106:1 and

$$(p-r) = -106 \times (+54 \times 10^3) = -5.7 \times 10^6 \text{ mol C d}^{-1} \text{ or } -11 \text{ mmol m}^{-2} \text{ d}^{-1}.$$

The system appears to be net heterotrophic. If the reacting organic matter is mangroves or other terrigenous organic detritus, the C:P ratio may be as high as 1000:1. In that case, $(p-r) = -54 \times 10^6 \text{ mol C d}^{-1}$, or $-108 \text{ mmol m}^{-2} \text{ d}^{-1}$.

As an aside, Δ alkalinity for this system is about $+82 \text{ mmol m}^{-2} \text{ d}^{-1}$. The source of the alkalinity is presumably the oxidation of organic matter via sulfate reduction in the sediments, as discussed by Gordon *et al.* (1996). This implies that the higher net respiration rate may be more correct.

5. REFERENCES

- Abraham, E. 1998 C-SEX Physical Atlas: CTD data from the 1996/97 cross-shelf exchange cruises north-east New Zealand. Unpublished data report NIWA Greta Point Library.
- Anderson, J.R. and Storey, K.J. 1981 Temperature, salinity, turbidity and tidal data for eight estuaries on the south coast of NSW, 1974-78. CSIRO, Canberra, *Technical Memorandum* **81/20**.
- Anonymous 1973 *Environmental study of Port Phillip Bay Report on Phase One: 1968-1971*. Melbourne & Metropolitan Board of Works, and Fisheries & Wildlife Dept of Victoria.
- Anonymous 1998 Task PL1: Point source loads. *Brisbane River and Moreton Bay Wastewater Management Study*. Sinclair Knight Merz.
- Appleyard, S. 1992 Estimated nutrient loads discharged into the Swan Canning estuary from groundwater. *Hydrology report No. 1992/20*. Geological Survey, Perth. GSWA File No. 119/1992.
- Bek, P. and Bruton, G. 1979 Gippsland lakes and streams: Hydrochemistry. *A report to the environmental studies section, Ministry for Conservation, Victoria. Environmental studies series No. 238*.
- Bird, E. D. F. 1978 The geomorphology of the Gippsland Lakes. *Ministry for Conservation, Victoria. Environmental studies series No. 186*.
- Black, K.P., Bell, R.G., Oldman, J.W., Carter, G.S. and Hume, T.M. Features of 3-dimensional barotropic and baroclinic circulation in the Hauraki Gulf, New Zealand. Submitted to: *New Zealand Journal of Marine and Freshwater Research*.
- Brown, 1968 Shoreline Development: Lake Illawarra. *Masters Thesis*, Geography Department, University of Sydney, New South Wales.
- Buckee, J., Rosich, R.S. and Van Senden, D.C. 1994 *Perth Coastal Waters Study*. Water Quality Data. Water Authority of Western Australia, John Tonkin Water Centre, Leederville WA
- Bureau of Meteorology 1974-1985 Monthly Climatic Reports. Canberra
- Cambridge, M.L. 1975 Seagrasses of south-western Australia with special reference to the ecology of *Posidonia australis* Hook F in a polluted environment. *Aquatic Botany* **1**, 149-161.
- Chiffings, A.W. 1987 Nutrient Enrichment and Phytoplankton Response in Cockburn Sound, PhD Thesis, Univ. West. Aust.
- Churchill, D.M. 1959 Late Quaternary eustatic changes in the Swan River district. *Journal of the Royal Society of Western Australia* **42**, 53-55.
- Clarke, D.J. and Elliot, I.G. 1984 Wind-driven circulation in Lake Illawarra, New South Wales, a numerical simulation. *Coastal Research Report No. 2/84*, Department of Mathematics, University of Wollongong, New South Wales.
- Close, M.E. and Davies-Colley, R.J. 1990 Baseflow water chemistry in New Zealand rivers. 1. Characterization. *New Zealand Journal of Marine and Freshwater Research* **24**, 319-328.
- Collie, T. 1994 Dry weather intensive water quality sampling: Lake Illawarra. *AWT Science and Environment, Wollongong, Report No. 92/103*.

- Coughanowr, C. (1995) The Derwent Estuary Nutrient Program. DELM, Hobart.
- Coughanowr, C. (1997) State of the Derwent Estuary: a review of environmental quality data to 1997. *Supervising Scientist Report 129*, Supervising Scientist, Canberra.
- Davey, S. 1994 Nutrient flux rates in sediments in Lake Illawarra. EMI, AWT and the Water Board, Wollongong.
- Davidson, W.A. 1981 A flow-net analysis of the unconfined groundwater in the 'superficial formation' of the southern Perth area, Western Australia. *Hydrogeology Report No. 2309. Geology Survey, Department of Mines, Western Australia 20* and maps.
- Davidson, W.A. 1995 Hydrogeology and groundwater resources of the Perth region, Western Australia. *Geological Survey of Western Australia Bulletin 142*, Perth, Western Australia.
- DEP (Department of Environmental Protection) 1996 *South Metropolitan Coastal Waters Study 1991-1994. Final Report 17*. Department of Environmental Protection, Perth, WA.
- ELCOM (Electricity Commission) of NSW 1984 Water quality dataset, June 1981 to June 1983. *ELCOM Technical Report No. DE 198*.
- ELCOM (Electricity Commission) of NSW 1987 Assessment of water quality of Lake Illawarra.. *ELCOM Technical Report No. PD 180*.
- Environment Waikato 1998a Environmental Monitoring 1997 Data Report. *Environment Waikato Technical Report 1998/05*.
- Environment Waikato 1998b Regional Rivers Water Quality Monitoring Programme Data Report 1997. *Environment Waikato Technical Report 1998/12*.
- ERM McCotter and Associates Pty Ltd 1994 Lake Illawarra entrance improvements: environmental impact study. For Lake Illawarra Authority, Wollongong.
- Eyre, B.D. 1994 Nutrient biogeochemistry in the tropical Moresby River estuary system north Queensland, Australia. *Estuarine, Coastal and Shelf Science 39*, 15-31.
- Eyre, B.D. 1995 A first-order nutrient budget for the tropical Moresby Estuary and catchment North Queensland, Australia. *Journal of Coastal Research 11*, 717-732.
- Eyre, B.D. 1998 Transport, retention and transformation of material in Australian estuaries. *Estuaries 21*, in press.
- Eyre, B.D. and Balls, P. A comparative study of nutrient behaviour along the salinity gradient of tropical and temperate estuaries. *Estuaries*, in press.
- Eyre, B.D. and Twigg, C., 1997 Nutrient behaviour during post-flood recovery of the Richmond River Estuary northern NSW, Australia. *Estuarine, Coastal and Shelf Science 44*, 311-326.
- Fairbridge, R.W. 1950 The geology and geomorphology of Point Peron, Western Australia. *Journal of the Royal Society of Western Australia 34*,35-72.
- Ferguson, C., Long, J. and Simeoni, M. 1995 Stormwater Monitoring Project 1994 Annual Report: Volume 1. *Australian Water Technologies, Sydney, Report No. 95/49*.
- France, R.E. 1978 The sedimentology of barrier and fringing banks in Cockburn Sound and the effect of industrial development on sedimentation. Report of the Sedimentology and Marine Geology Group, Department of Geology, University of Western Australia.

- Fredericks, D.J., Heggie, D.T., Watkins, K. and Longmore, A. 1997 Nutrient, hydrocarbon and agrichemical fluxes in the Swan Canning estuary. *Australian Geological Survey Organisation, Petroleum and Marine Division, Canberra.*
- Gordon, D.C. Jr., Boudreau, P.R., Mann, K.H., Ong, J.-E., Silvert, W.L., Smith, S.V. Wattayakom, G., Wulff, F. and Yanagi, T. 1996 LOICZ Biogeochemical Modelling Guidelines. *LOICZ/R&S/ 95-5*, LOICZ, Texel, The Netherlands.
- Harris, G.P., Batley, G., Fox, D., Hall, D., Jernakoff, P., Molloy, R., Murray, A., Newell, B., Parslow, J., Skyring, G. and Walker, S. 1996 *Port Phillip Bay Environmental Study: Final report*. CSIRO, Dickson, ACT Australia.
- Harris, G.P., Batley, G., Webster, I.T., and Molloy, R. 1998 *Gippsland Lakes environmental audit: Preliminary review of water quality and status of the Aquatic ecosystems of the Gippsland Lakes*. A report prepared for the Gippsland Coastal Board.
- Hean, D.S. and Nanson, G.C. 1985 Geomorphological investigations of stream channel and alluvial deposits in areas of proposed urban development within the catchment of Lake Illawarra. University of Wollongong, Department of Geography.
- Heath, R.A., Greig, M.J.N. and Shakespeare, B.S. 1977 Circulation and hydrology of Manukau Harbour. *New Zealand Journal of Marine and Freshwater Research* **11**, 589-607.
- Hossain, S. 1998 Hydrology and suspended sediment transport in the Richmond River catchment and estuary NSW Australia. *PhD thesis*, Southern Cross University, New South Wales.
- Kanamori, S. 1976 Water Pollution Studies on Lake Illawarra.. *PhD thesis*, Chemistry Department, University of Wollongong, New South Wales.
- Lake Illawarra Authority 1995 Lake Illawarra works program environmental appraisal : Impact on lake nutrient dynamics. Department of Public Works, Sydney.
- Lake Illawarra Authority 1998 Restoration Project Site Tour Notes. Wollongong, New South Wales.
- Layton Groundwater Consultants 1979 Cockburn Sound groundwater study for the Cockburn Sound Study Group. Department of Conservation and Environment. Western Australia.
- Longmore, A.R., Cowdell, R.A., and Flint, R. 1996 Nutrient status of the water in Port Phillip Bay. *Port Phillip Bay Environment Study Technical Report no. 24*. Melbourne.
- Mills D.A. and D'Adamo N. 1995 The application of a three dimensional baroclinic model to the hydrodynamics and transport of Cockburn Sound, Western Australia and surrounding waters. *Technical Report Series 76*, Dept of Environmental Protection, Perth Western Australia
- Murphy, P.J. 1979 *Technical report on industrial effluents. Report No 6*. Department of Conservation and Environment. Western Australia.
- Murray, A.M. and Parslow, J.S. 1997 Port Phillip Bay Integrated Model: Final report. *Port Phillip Bay Environmental Study Technical Report No. 44*, CSIRO, Canberra.
- National Environmental Consulting Services 1997 Lake Illawarra: assessment of foreshore habitat enhancement opportunities. NECS, Canberra.

- New South Wales Environmental Protection Authority 1994 *Water quality Hawkesbury-Nepean River system June 1990 to June 1993*.
- Nicholson, G.J., Longmore, A.R., and Cowdell, R.A. 1996 Nutrient status of the sediments of Port Phillip Bay. *Port Phillip Bay Environment Study Technical Report No. 26*, Melbourne.
- Pernetta, J.P. and Milliman, J.D. 1995 *LOICZ Implementation Plan*, Report No. 33 IGBP: Stockholm.
- Pickmere, S.E. 1998 Biological effects of cross-shelf water transfer programme nutrient report. *NIWA Internal Report 98/04*.
- Pont, D. 1998 Sediment, nitrogen and phosphorus exports from 13 eastern Australian catchments during a flood year. *Honours Thesis*, Southern Cross University, New South Wales.
- Pritchard, D.W. 1969 Dispersion and flushing of pollutants from estuaries. *Proceedings of the American Society of Civil Engineers 95*, HY1: 115-124.
- Proctor, R. and Greig, M.J.N. 1989 A numerical model investigation of the residual circulation in Hauraki Gulf, New Zealand. *New Zealand Journal of Marine and Freshwater Research. 23*, 421-442.
- Public Works Department 1988 Lake Illawarra hydrographic survey general plan. Drawing Numbers: 882128 - 2 and 882128 - 3. Scale 1:10,000.
- Robinson, D.P. 1995 *Water quality and nutrient status of Lake Wellington*. Environmental Protection Authority, Victoria.
- Sharples, J. 1997 Cross-shelf intrusion of subtropical water into the coastal zone of north-east New Zealand. *Continental shelf research 177*, 835-857.
- Sharples, J. and Greig, M.J. 1998 Tidal currents, mean flows, and upwelling on the north-east shelf of New Zealand. *New Zealand Journal of Marine and Freshwater Research. 32*, 215-231.
- Simeoni, M., Hickey, C., Gillespie, L., Kachka, A. and Vorreiter, L. 1995 Stormwater Monitoring Project 1993 Annual Report. Volume 1. *Australian Water Technologies, Sydney, Report No. 94/93*.
- Sokolov, S. 1996 Inputs from the Yarra River and Patterson River/Mordialloc Main Drain into Port Phillip Bay. *Port Phillip Bay Environment Study Technical Report No. 33*, Melbourne.
- SPCC 1983 *Water quality in the Hawkesbury-Nepean River: a study and recommendations*. State Pollution Control Commission, Sydney, New South Wales.
- Standing Committee on Public Works 1996 *The Lake Illawarra Authority. Report No. 3*.
- Steedman, R.K., and Craig, P.D. 1979 Numerical model study of circulation and other oceanographic aspects of Cockburn Sound. *Report for the Department of Conservation and Environment. Western Australia*.
- Steedman, R.K., and Craig, P.D. 1983 Wind driven circulation of Cockburn Sound. *Australian Journal of Marine and Freshwater Research 34*, 187-212
- Stevens, R. and Imberger, J. 1996 Dynamics of the Swan River estuary: the seasonal variability. *Marine and Freshwater Research 47*, 517-29
- Sydney Water 1991 Lower Hawkesbury-Nepean study area – sewerage systems, existing conditions. Volume 1, December 1991.

- Sydney Water 1998 Licensing sewerage overflows: Environmental impact statement. Sydney Water, Sydney.
- Vant, W.N. and Williams, B.C. 1992 Residence times of Manukau Harbour, New Zealand. *New Zealand Journal of Marine and Freshwater Research* **26**,393-404.
- Vant, W.N. and R.G. Budd 1993 Phytoplankton photosynthesis and growth in contrasting regions of Manukau Harbour, New Zealand. *New Zealand Marine and Freshwater Research* **27**, 295-307.
- Walker, S.J. 1997 A transport model of Port Phillip Bay. *Port Phillip Bay Environment Study Technical Report No. 39*, Melbourne
- WCC and UOW (Wollongong City Council and The University of Wollongong) 1976 *Illawarra Lake: An Environmental Assessment Project*. Wollongong, New South Wales.
- Wood, P.J. 1983 Evolution of, and soil development on, Holocene beach ridge sequences, west coast, Western Australia. *Ph D thesis*, University of Western Australia.
- Woodward, C.J. 1986 An assessment of long term phosphorus inputs to Lake Illawarra. *Master of Engineering Honours Thesis*, Engineering Department, University of Wollongong.
- Zeldis, J.R., Sharples, J., Uddstrom, M. and Pickmere, S. 1998 Fertilising the continental shelf: biological oceanographic studies on the northeastern New Zealand continental margin. *Water and Atmosphere* **6**(1), 13-16.

APPENDICES

APPENDIX 1 **The response of Australian estuaries and coastal embayments to increased nutrient loadings and changes in hydrology.**

Graham Harris

[This paper was presented as the opening plenary of the Workshop.]

Introduction

The Australian continent is old, weathered and largely dry, with the lowest runoff of any major continent (Williams 1975, Alexander 1985). Apart from the northern, tropical part of the continent where monsoonal rains produce high runoff, estuaries and coastal embayments in the southern, temperate and subtropical parts of the continent are generally marine environments with small freshwater inflows (e.g., Port Phillip Bay, Harris *et al.* 1996). The coasts of the south-eastern part of Australia are dotted with coastal embayments formed from drowned valleys during sea level rise since the last glacial period (Bayly 1975). Most of these embayments are cut off from the sea by sand bars and dune systems so that tidal exchange is also small and water residence times are long (Jennings and Bird 1967). The coastal sand bars frequently close off altogether during dry periods. Many Australian coastal systems therefore become slightly hypersaline during the summer period when evaporation is most rapid.

The oceans of the southern parts of Australia tend to be warm temperate or subtropical and poor in nutrients (Rochford 1975) so the marine inputs of nutrients are consequently low. Thus we have many generally marine ecosystems in coastal embayments which, because of the low freshwater inflows and tidal exchanges, tend, in their pristine states, to be oligotrophic and dominated by seagrasses. When freshwater inflows do occur they tend to be large and infrequent (the variance in rainfall in Australia is very high, Alexander 1985) and the water residence time, T_w , may intermittently go from hundreds of days to a few days or less. (It is recognised that the concept of a water residence time is sometimes difficult to apply to estuarine systems; Officer and Kester 1991, Oliveira and Baptista 1997). While these ecosystems evolved to cope with the rather extreme climate and climate variability of the continent they are nonetheless very sensitive to changes in T_w induced by extensive damming and regulation of the coastal rivers for water supplies and irrigation.

Because the water residence times of these systems are often long, the water quality is dominated by sediment-water column exchanges. The role of the benthos and microbial metabolism frequently dominates the ecosystem response to external loads – denitrification is very important in these systems (Harris *et al.* 1996). Because sediment nutrient pools and regrowth of seagrasses dominate the ecosystem response to intermittent loads, these systems are rarely at steady state and are always in a state of adjustment to the last extreme event which may have been years before.

Most of the Australian coastal embayments and estuaries are shallow – even Port Phillip Bay with an area of 2 000 km² has a maximum depth of barely 20 metres. This means that there is extensive contact between the sediments and the water column driven by

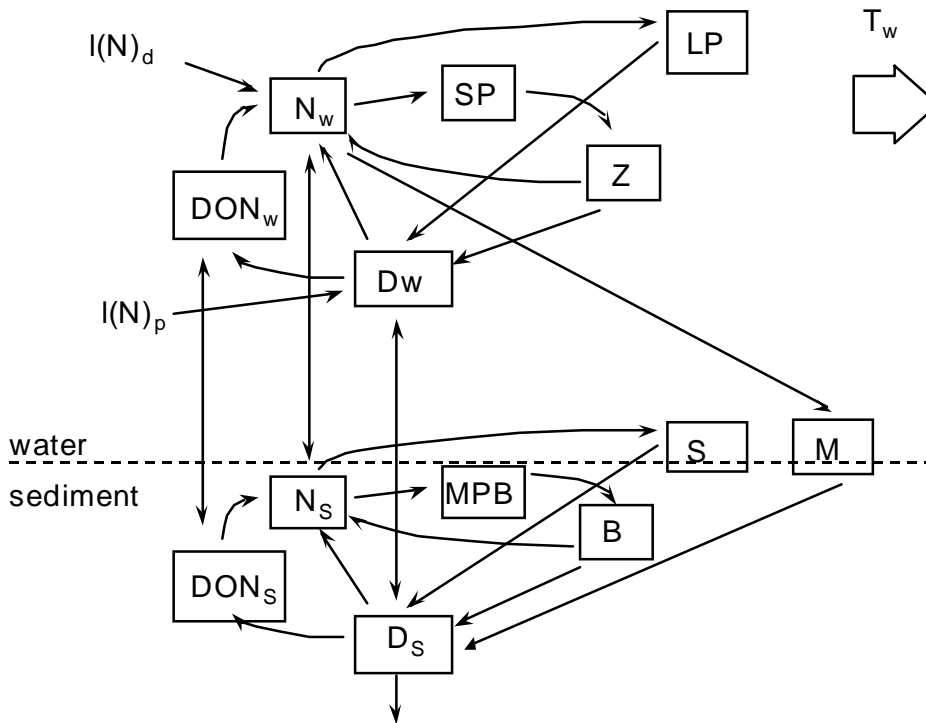

Figure I.1. A schematic diagram of the model. (The model was run with all stocks and flows calculated as nitrogen per unit area and for a 5m deep, fully-mixed water column. The exchanges between the sediment and the water column were calculated from the concentration difference and a diffusion coefficient. Nutrient (nitrogen) loads were split between dissolved [I(N)p] and particulate [I(N)d] fractions. Components as follows:

N_w , dissolved inorganic nitrogen in the water column; DON_w , dissolved organic nitrogen in the water column; D_w , detritus in the water column; SP , small phytoplankton; LP , large phytoplankton; Z , zooplankton; N_s , dissolved inorganic nitrogen in the sediment pore waters; DON_s , dissolved organic nitrogen in sediment pore waters; D_s , detritus in the sediment; MPB , microphytobenthos; B , benthic grazers; M , macrophytic algae (sea weeds); S , seagrasses.

Note that while M source nutrients from the water column, S draw nutrients from the sediments. The model calculated all light extinctions (m^{-1}) from sum of the biomass of phytoplankton ($SP+LP$), DON_w and D_w in the water column. Physiological parameters and grazing coefficients were derived from standard literature values ; Murray and Parslow 1997.)

wave action and wind driven currents. Because many systems are only a few metres deep, light intensities on the sediment surface are high and there is an extensive littoral zone. Macrophytic marine algae (seaweeds), seagrasses and microphytobenthos, in particular (Light and Beardall 1998), are important functional groups in these ecosystems. Where they are abundant, large beds of macrophytes may change the response of coastal ecosystems to nutrient loads so that the expected planktonic algal blooms are suppressed (Borum and Sand-Jensen 1996). These features are echoed in the model structure and its functional response (Figure I.1).

As might be expected, these coastal systems are very popular tourist destinations and some are beginning to suffer from the usual problems associated with agricultural and urban development – eutrophication, algal blooms, loss of seagrasses and overfishing. Luckily, because of low freshwater inflows and low population densities, many of the Australian coastal ecosystems are still relatively unpolluted so we have many pristine systems. Nonetheless, there are a number of coastal ecosystems that are beginning to show signs of stress and some are seriously impacted (Scanes *et al.* 1997, Harris *et al.* 1998).

Predictive models

In an effort to understand some of the important interactions in these ecosystems and to begin to tease out some of the controls on ecosystem structure and processes, I built a simple ecosystem model for these systems (Figure I.1). Much of the conceptual development of this model was carried out during the Port Phillip Bay Study so I owe a debt of gratitude to the other members of the Study team (see Harris *et al.* 1996, Murray and Parslow 1997). Further details of the conceptual development of the model used in this paper may be found in Harris (1997, 1998). This model describes the ecosystems of the coastal embayments of southeastern Australia. One major functional group not included in this model is the mangroves that dominate coastal ecosystems in protected sub-tropical and tropical estuaries. There is no reason why further versions of this model should not include this group.

In brief, the model employs well understood relationships for photosynthesis, nutrient uptake and growth, grazing and sinking and uses well established literature values for half-saturation constants, maximum growth rates, light saturation parameters, grazing efficiencies and sinking rates (Murray and Parslow 1997). The model was written as a nitrogen model for the ecosystem because of widespread evidence of nitrogen limitation in Australian coastal waters, a fact that was thoroughly documented in the Port Phillip Bay Study (Harris *et al.* 1996). The model was calibrated and validated by comparisons with a number of well documented ecosystem responses to nutrient loads e.g., dissolved inorganic to total nutrient ratios, algal biomass responses, export production and the organic load to the sediment, responses of functional groups to external loads. All these empirical responses are described in the literature. Full details of this model will be published elsewhere.

The important objective of this work was to explore the ecosystem behaviour and responses to loadings and flushing through the interactions between the functional

groups, rather than to develop new formulations for the responses of the groups themselves. An examination of Figure I.1 will show that broadly there are a set of pelagic interactions and a set of benthic interactions controlled by analogous sets of functional groups. This choice of model structure is outlined in Harris (1997, 1998). What emerges is a strongly non-linear response of the model to changes in nutrient loadings and hydraulic flushing which results from competition for light and nutrients between the organisms in the water column and those on the sediment surface. The model incorporates a simple empirical relationship between benthic denitrification efficiencies and the internal load of carbon and nitrogen from the water column (Harris *et al.* 1996, Murray and Parslow 1997). High denitrification efficiencies in the Bay were dependent on high bioturbation and irrigations rates by the macrobenthos.

Work in Port Phillip Bay confirmed what has been observed elsewhere (Smith *et al.* 1989, 1991, 1997; Smith and Hollibaugh 1989, 1997); that P:R ratios in estuaries and coastal waters can be estimating by examining C, N and P budgets and using Redfield proportions. Using a nutrient budgeting approach, Smith *et al.* (1989, 1991, 1997) have shown a close linkage between the net carbon balance of estuarine ecosystems and denitrification. Many estuaries are heterotrophic (Smith *et al.* 1997) but, from the data available, it would seem that temperate estuaries tend to be more autotrophic than tropical and subtropical systems. More Australian data are presented elsewhere in this paper which confirm this general pattern. In this paper, the model is used to examine how the various functional groups in the ecosystem interact with external loads and flushing times to recycle and retain nutrients within the ecosystem.

Model results – ecosystem responses to nutrient loads and changes in flushing rates.

1. Functional groups and ecosystem function.

It is possible to use the model to calculate retention coefficients ($R_C\%$, as in Dillon and Rigler 1974), that is, the balance of nutrient inputs, system storage and export. The relationships between T_W and $R_C\%$ are well known for phosphorus and for lakes where it is a simple matter to measure the loads to and exports from confined water bodies (Dillon and Rigler 1974, Kirchner and Dillon 1976, Larsen and Mercier 1976, Ostrofsky 1978). Empirical work by Vollenweider and others showed that the best scalar for flushing rates is $1/(1 + \sqrt{T_W})$. The retention coefficients for nitrogen and for estuaries are less well known because nitrogen itself is less well studied, and tidal exchanges make it more difficult to calculate T_W for estuaries (Oliveira and Baptista 1997) – but see Johnson *et al.* (1995) for a mass balance nutrient budget for a coastal sea lough. Plotting $R_C\%$ versus $1/(1 + \sqrt{T_W})$ from the model (Figure I.2) gives results which look very like lakes – $R_C\%$ declines from about 80% at water residence times in excess of 100 days to between 25 and 50% at residence times of just a few days. $R_C\%$ declines at long residence times if the critical load is exceeded.

Figure I.2 The relationship between flushing time and retention of nitrogen. (At long flushing times, retention coefficients decline sharply if the critical load is exceeded and the ecosystem becomes plankton dominated (lower points, left of graph). Nitrogen loads of $8-10 \text{ mgN m}^{-2} \text{ d}^{-1}$ are sufficient to cause the “critical load” to be exceeded if the water residence time is long enough.)

Figure I.3 The relationship between flushing times and retention of nitrogen in the model ecosystem with either all functional group present or with macrophytes or benthic denitrification deleted. (Note that at short residence times the uptake of nutrients by macrophytes (macrophytic algae and seagrasses) dominates the retention of nutrients whereas at longer residence times benthic processes dominate. Note also that flushing dominates the retention of nutrients when denitrification is deleted and that the system exports nitrogen (negative retention) when flushed.)

Also using the model it is possible to calculate the effect of deleting certain functional groups. This gives an idea of the functional group playing the most important role in

determining $R_C\%$ at various water residence times. The results from these simulations are displayed in Figure I.3.

At short water residence times (2-20 days), the macrophytes are the main functional group taking up and retaining the load whereas at longer residence times the benthic denitrification (resulting from sedimentation from the pelagic) is clearly the main determinant of the retention of nutrients in the system. This makes sense when it is remembered that short residence times will tend to flush out the plankton and swing the balance in favour of the littoral and demersal macrophytes.

2. Directional change and hysteresis in the response to nutrient loads.

The model quite clearly shows that the ecosystem has a highly non-linear response to nutrient load. There is, in effect, a “critical load” beyond which the system changes markedly and it is difficult to restore the oligotrophic functional groups and system function. This hysteresis is related to the finite capacity for denitrification in the system driven by organic loads to the sediment. Port Phillip Bay showed this response clearly (Harris *et al.* 1996).

The use of both small and large phytoplankton functional groups ensures that blooms of large phytoplankton result from increased nutrient loads (as is observed in Australian coastal waters, Hallegraeff 1981, Hallegraeff and Reid 1986) and that the organic load to the sediment rises sharply with increasing nutrient loads. These increased nitrogen loads to the sediment are initially efficiently denitrified. Once the organic loads to the sediment from pelagic production are sufficient to induce anoxia in the sediments both nitrification and denitrification cease and the sediment pools of nitrogen build up (Figure I.4). The decomposed nitrogen is then returned to the water column as an internal load. This further stimulates phytoplankton blooms resulting in the highly non-linear response of the system.

Figure I.4 The effects of rising and falling loads on both large phytoplankton (LP) and the dissolved inorganic nitrogen in the sediments (DIN). (The pool sizes rise by

the lower route and fall via the upper points when the nutrient load is reduced after inducing eutrophic conditions.)

Lakes show a similar increase in internal phosphorus load from the sediment once eutrophication has been induced (Nurnberg 1984, 1988). The situation is exacerbated in shallow estuaries and embayments where there is good contact between sedimentary nutrient pools and the water column.

Blooms of phytoplankton in the water column lead to the shading off and death of the seagrasses (as has been observed in Western Australia by Silberstein *et al.* 1986). The sequence of events in Australian coastal embayments and estuaries, as nutrient loads are increased, is for the seagrasses to first show epiphytic overgrowths. This is followed by the development of macrophytic algal beds (which are often free-floating and which drift with the tide, Harris *et al.* 1996), and finally by the development of phytoplankton blooms.

When eutrophic, the system switches from a clear, macrophyte-dominated system with high nutrient retention and high denitrification efficiencies to a turbid, phytoplankton-dominated system with low denitrification efficiencies, high nutrient concentrations in the water column and higher exports (Figure I.2). Lakes are well known to exhibit similar behaviour (Blindow *et al.* 1993, 1997). The model results show the same switch between states for estuaries (Figure I.5). There are many parallels between shallow lakes and estuaries.

Figure I.5 The inverse relationship predicted by the model for total phytoplankton biomass and macrophyte biomass in the 5m water column. (The points are plotted as the biomass of each functional group after 500 days of simulated time with various external nutrient loads.)

Because of the cessation of benthic denitrification once the “critical load” has been reached (and the consequent build-up of sedimentary nutrient pools, Figure I.4), the ecosystem shows marked hysteresis to increasing and reducing nutrient loads (Harris *et al.* 1996, Murray and Parslow 1997, Parslow 1998). Until benthic denitrification has

Figure I.6 The relationship between nitrogen load and the response of the dominant functional groups. (Under slowly increasing loads the seagrasses are initially dominant followed in order by macrophytes and finally phytoplankton blooms (upper figure). This is consistent with observations in Australian coastal ecosystems. If the “critical load” is exceeded and the phytoplankton blooms are produced, then the load has to be reduced considerably to achieve the desired oligotrophic state (lower figure). This may not always be possible.)

Figure I.7 The change in system state with constant load and varying flushing time. (At the left [flushing time = 25 days] the water column is clear, nutrient levels are low, denitrification efficiencies are high, macrophytes are abundant and algal blooms are absent. At the right [flushing time = 50 days] algal blooms appear, the water column is turbid, denitrification efficiencies are low and the nitrogen concentration in the water column rises, macrophytes disappear.)

been re-established (and this requires a marked reduction in load to reduce the production and sedimentation of organic matter to the sediments, as was observed in Port Phillip Bay, Harris *et al.* 1996), the system stays in a eutrophic state. Here, the sedimentary nitrogen fluxes are dominated by ammonia until the external nutrient load has been markedly reduced. Once benthic denitrification ceases, the only way to eliminate the excess nutrient is by flushing – either by the tide or by low nutrient freshwater inflows. Degraded coastal embayments such as the Gippsland Lakes in Victoria (Harris *et al.* 1998) export ammonia to the ocean on the falling tide (Figure I.3).

The ecosystem response to nutrient loads therefore depends on the history of extreme events and the ecosystem state when the load is applied. Increasing and decreasing loads produce quite different responses by the functional groups (Figure I.6). Simple visual observations of which functional groups are present can be useful indicators of ecosystem state (Scanes *et al.* 1998) but depend on the marked hysteresis in response to changing loads. Certainly it is difficult to restore degraded coastal ecosystems - in cases such as Port Phillip Bay the reduction in nitrogen loading required to restore the ecosystem once the critical load is exceeded cannot be achieved without removal of the city of Melbourne from the catchment!

3. The importance of water residence times (and the lack of long term steady state).

One surprising outcome of the model was its extreme sensitivity to water residence times and to flushing. On reflection this is, perhaps, to be expected. Variability in T_w leads to changes in the competition between the pelagic and benthic groups for light and nutrients and alters the removal rates of the pelagic components (Figure I.1). At long T_w , the pelagic groups are favoured by giving phytoplankton populations time to build up and shade-off the benthos. At short T_w , the pelagic groups are flushed out clearing the water for the seagrasses. At intermediate nutrient loads, it is possible to switch the ecosystem state from turbid and plankton-dominated to clear and macrophyte-dominated merely by changing the water residence time from 25 to 50 days (Figure I.7).

This means that in coastal Australia the changes in T_w brought about by river regulation, water extraction, dams and diversions have probably had as much of an impact on the coastal ecosystems as has the increase in nutrient loads due to urban and agricultural development in coastal catchments. By changing the frequency distribution of the already infrequent freshwater inflows and by increasing the water residence times, we have increased the probability of planktonic algal blooms even before any changes in nutrient loads. Through deforestation and the growth of urban and agricultural land use, we have increased the turbidity of freshwater inflows and therefore increased the negative impacts on seagrasses and macrophytes in the shallow coastal embayments. By changing the hydrology and water quality of Australian rivers so markedly, we have altered the ecology of Australian coastal systems in ways that we do not presently fully understand.

Given the long time-scale of turnover of the sediment nutrient pools and the similarly long time required for the regrowth of seagrasses, then these coastal ecosystems are never at steady state, being always responding to the most recent extreme event in the catchment. Most of the south-eastern region of Australia is strongly impacted by

alternating droughts and floods resulting from El Nino/Southern Oscillation events at time scales of seven to ten years. This climate variability has a strong impact on freshwater, estuarine and coastal marine ecosystems (Harris *et al.* 1988, Harris and Baxter 1996).

Conclusions

This simple exercise in estuarine modelling has demonstrated that it is possible to reproduce most of the observed systems dynamics through manipulating the interactions between the major functional groups. Interactions between functional groups yield the marked non-linearity of the ecosystems to nutrient loads. The changes in benthic denitrification ensure that a “critical load” is observed, beyond which it is difficult to restore the system. As well as reproducing the responses of the functional groups to changes in loads, this approach also adequately reproduces whole system properties such as nutrient retention coefficients. Nutrient budgeting approaches and the biogeochemistry of major elements, such as reported elsewhere in this volume, will depend on the ecosystem state in these coastal ecosystems. Models such as this can be used to explore system function as well as the response of coastal ecosystems to various management options.

REFERENCES

- Alexander, W.J.R. 1985 Hydrology of low latitude southern hemisphere land masses. *Hydrobiologia* **125**, 75-83
- Bayly, I.A.E. 1975 Australian Estuaries. In Nix, H.A. and Elliott, M.A. eds *Managing Aquatic Ecosystems. Proceedings of the Ecological Society of Australia* **8**, 41-66.
- Blindow, I., Andersson, G., Hargeby A., and Johansson, S. 1993 Long term pattern of alternative stable states in two shallow eutrophic lakes. *Freshwater Biology* **30**, 159-167.
- Blindow, I., Hargeby, A. and Andersson G. 1997 Alternative stable states in shallow lakes: what causes a shift? In Jeppesen, E., Sondergaard, M. and Christoffersen, K. eds *The structuring role of submerged macrophytes in lakes, Ecological Studies* **131**, 353-360. Springer Verlag, New York.
- Borum, J. and Sand-Jensen, K. 1996 Is total primary production in shallow coastal marine waters stimulated by nitrogen loading? *Oikos* **76**: 406-410
- Dillon, P.J. and Rigler F.H. 1974 A test of a simple nutrient budget model predicting the phosphorus concentration of lake water. *Journal of the Fisheries Research Board of Canada*. **31**: 1771-1778
- Hallegraeff, G.M. 1981 Seasonal studies of phytoplankton pigments and species at a coastal station off Sydney: importance of diatoms and the nanoplankton. *Marine Biology* **61**: 107-118.
- Hallegraeff, G.M. and Reid, D.D. 1986 Phytoplankton species successions and their hydrological environment at a coastal station off Sydney. *Australian Journal of Marine and Freshwater Research* **37**, 361-377.

- Harris, G.P. 1997 Algal biomass and biogeochemistry in catchments and aquatic ecosystems: scaling of processes, models and empirical tests. *Hydrobiologia* **349**, 19-26.
- Harris, G.P. 1998 Predictive models in spatially and temporally variable freshwater systems. *Australian Journal of Ecology* **23**, 80-94.
- Harris, G.P., Batley, G., Fox, D., Hall, D., Jernakoff, P., Molloy, R., Murray, A., Newell, B., Parslow, J., Skyring, G. and Walker, S. 1996 *Port Phillip Bay Environmental Study: Final report*. CSIRO, Dickson, ACT Australia.
- Harris, G.P., Batley, G., Webster, I., Molloy, R. and Fox, D. 1998 Review of water quality and status of the aquatic ecosystems of the Gippsland Lakes. *Contract report for the Gippsland Coastal Board*. CSIRO Environmental Projects Office, Melbourne.
- Harris, G.P. and Baxter, G. 1996 Interannual variability in phytoplankton biomass and species composition in a subtropical reservoir. *Freshwater Biology* **35**, 545-560.
- Harris, G.P., Davies, P., Nunez, M. and Meyers, G. 1988 Interannual variability in climate and fisheries in Tasmania. *Nature London* **333**, 754-757.
- Jennings, J.N. and Bird, E.C.F. 1967 Regional geomorphological characteristics of some Australian estuaries. in Lauff, G.H. (ed.) *Estuaries*. American Association for the Advancement of Science. Publ. No. **83**.
- Johnson, M.P., Costello, M.J. and O'Donnell D. 1995 The nutrient economy of a marine inlet: Lough Hyne, South West Ireland. *Ophelia* **41**, 137-151.
- Kirchner, W.B. and Dillon, P.J. 1975 An empirical method of estimating the retention of phosphorus in lakes. *Water Resources Research* **11**, 182-183.
- Larsen, D.P. and Mercier, H.T. 1976 Phosphorus retention capacity of lakes. *Journal of the Fisheries Research Board of Canada* **33**, 1742-1750.
- Light, B.R. and Beardall, J. 1998 Distribution and spatial variation of benthic microalgal biomass in a temperate, shallow water marine system. *Aquatic Botany* **61**, 39-54.
- Murray, A. and Parslow, J. 1997 Port Phillip Bay integrated model: Final report. *Port Phillip Bay Environmental Study, Technical Report No. 44*, CSIRO Environmental Projects Office, Canberra ACT, Australia.
- Nurnberg, G.K. 1984 The prediction of internal phosphorus load in lakes with anoxic hypolimnia. *Limnology and Oceanography* **29**, 111-124.
- Nurnberg, G.K. 1988 Prediction of soluble phosphorus release rates from total and reductant-soluble phosphorus in anoxic lake sediments. *Canadian Journal of Fisheries and Aquatic Science* **45**, 453-462.
- Officer, C.B. and Kester, D.R. 1991 On estimating the non-advective tidal exchanges and advective gravitational circulation exchanges in an estuary. *Estuarine and Coastal Shelf Science* **32**, 99-103.
- Oliveira, A. and Baptista, A.M. 1997 Diagnostic modeling of residence times in estuaries. *Water Resources Research* **33**, 1935-1946.
- Ostrofsky, M.L. 1978 Modification of phosphorus retention models for use with lakes with low areal water loadings. *Journal of the Fisheries Research Board of Canada* **35**, 1532-1536.
- Parslow, J. 1998 Simple estuarine eutrophication models. In *Coastal Nutrients Workshop, Proceedings*, Australian Water and Wastewater Association, Artarmon, NSW Australia.

- Rochford, D.J. 1975 Oceanography and its role in the management of aquatic ecosystems. In Nix, H.A. and Elliott, M.A. (eds) *Managing Aquatic Ecosystems. Proceedings of the Ecological Society of Australia* **8**, 67-83.
- Scanes, P. Coade, G., Large, D. and Roach, T. 1998 Developing criteria for acceptable loads of nutrients from catchments. In *Coastal Nutrients Workshop, Proceedings*, Australian Water and Wastewater Assoc., Artarmon, NSW Australia.
- Silberstein, K., Chiffings, A.W. and McComb, A.J. 1986 The loss of seagrass in Cockburn Sound, Western Australia. III. The effect of epiphytes on the productivity of *Posidonia australis*. Hook. F. *Aquatic Botany* **24**, 355-371.
- Smith, S.V. and Hollibaugh, J.T. 1989 Carbon-controlled nitrogen cycling in a marine 'macrocosm': an ecosystem-scale model for managing cultural eutrophication. *Marine Ecology Progress Series* **52**, 103-109.
- Smith, S.V. and Hollibaugh, J.T. 1997 Annual cycle and interannual variability of ecosystem metabolism in a temperate climate embayment. *Ecological Monographs* **67**, 509-533.
- Smith, S.V., Hollibaugh, J.T., Dollar, S.J. and Vink, S. 1989 Tomales Bay, California: a case for carbon controlled nitrogen cycling. *Limnology and Oceanography* **34**, 37-52.
- Smith, S.V., Hollibaugh, J.T., Dollar, S.J. and Vink, S. 1991 Tomales Bay metabolism: C-N-P stoichiometry and ecosystem heterotrophy at the land-sea interface. *Estuarine and Coastal Shelf Science* **33**, 223-257.
- Smith, S.V., Ibarra-Obando, S., Boudreau, P.R. and Camacho-Ibar, V.F. 1997 Comparison of carbon, nitrogen and phosphorus fluxes in Mexican coastal lagoons. *LOICZ reports and studies No. 10*, LOICZ Core Project Office, Texel, The Netherlands.
- Williams, W.D. 1975 Australian Inland Waters. In Nix, H.A. and Elliott, M.A. (eds) *Managing Aquatic Ecosystems, Proceedings of the Ecological Society of Australia* **8**, 19-40.

APPENDIX II Australasian coastal systems overview

**B. N. Opdyke, S. V. Smith, B. Eyre, D. T. Heggie,
G. G. Skyring, C.J. Crossland, and J. Zeldis**

The contiguous Australian continent has 30 000 km of coastline (at a resolution of about 10 km). It has been estimated to have over 750 estuaries and embayments along this margin. Australia spans 30 degrees of latitude and is unique among “first world” countries because of the substantial tropical and subtropical areas it occupies (Bucher and Saenger 1991). To expand this description to all of Australasia, we must add approximately 15 000 km of coastline for New Zealand and 5000 km of coastline for Papua New Guinea. Thus, the Australasian region has approximately 50 000 km of the world's ~600 000 km coastline. If we consider that much of the biogeochemical and biotic activity of the world's coastal zone is likely to be confined to a relatively narrow coastal strip (\ll shelf width), then the coastline length becomes one measure of the relative importance of a particular coastal zone at a global scale.

Some 86% of the Australian population lives in coastal regions, with beaches and marine activities holding an important role in Australian culture and activities. Similarly, New Zealand has a heavy population weighting toward coastal regions, with nearly all its major cities bordering the sea. Papua New Guinea's population, by contrast, is not primarily on the coast, with 80% living in the more mountainous regions. The total human population of the Australasian region is about 25 million.

Australian fisheries, like those in many nations around the world, have been over-exploited and mitigation of population pressures on coastal ecosystems has only recently been tackled as a major issue for state and local governments. Moreover, it will be demonstrated in the discussion to follow that land-based anthropogenic activities have significant impact on Australasian coastal systems. Similarly, maritime activities are central in New Zealand society, and coastal fisheries, mariculture and recreational use of the coastal zone are important. Land use changes associated with urbanisation and agriculture have affected New Zealand estuarine systems.

If salinity, evaporation, rainfall and runoff data are examined to calculate the ratio of average estuarine salinity (S_{sys}) to the oceanic end-member salinity (S_{ocn}), this ratio ($S_{\text{sys}}/S_{\text{ocn}}$), can be used as an indicator of freshwater storage. The flushing times of the freshwater from an estuary can also be established by looking at the integrated inventories of freshwater in the estuaries ($[S_{\text{ocn}} - S_{\text{sys}}]/S_{\text{ocn}} \times V_{\text{sys}}$), and the net precipitation + runoff - evaporation i.e., the net freshwater input rate. This, of course, is implicit in the LOICZ Biogeochemical Modelling Guidelines (Gordon *et al.* 1996) and is particularly useful in classifying Australian coastal systems.

Extending the classification of Eyre (1998) and using reasoning suggested by Heggie and Skyring (unpublished), we can subdivide the Australasian coastline into 8 major regions (Figure II.1).

Figure II.1 Classification of Australasian coastal zones.

I. Wet Tropical:- The high rainfall and runoff region in Papua New Guinea and smaller islands of Australasia north of the continent of Australia. Rainfall in Papua New Guinea typically is high all year, with annual rainfall exceeding $4000 \text{ mm year}^{-1}$ over much of the highland area. Most rivers of the region flow out of small, mountainous watersheds, and have some of the highest water and sediment yields of the world's rivers. These regions will typically show $S_{\text{syst}} \ll S_{\text{ocn}}$, with riverine influence extending onto the open shelf.

II. Wet/Dry Tropical:- Includes the monsoonal region of Northern Australia. Darwin is the only major city in the region. It is a sparsely populated coastline, with extensive fisheries and potential for petroleum exploration. It is characterised by hot, wet summers and warm, dry winters. These regions therefore show $S_{\text{syst}} \ll S_{\text{ocn}}$ in the summer and $S_{\text{syst}} > S_{\text{ocn}}$ in the winter.

III. Wet/Dry Subtropical:- The coast of Queensland south of about 15°S , extending down into northern New South Wales falls into this category. The city of Brisbane is within this region. Much of the region is characterised by intensive coastal agriculture. This region is also monsoonal, with warm, wet summers and cool, dry winters. Generally, estuaries show $S_{\text{syst}} \ll S_{\text{ocn}}$ in the summer and $S_{\text{syst}} < S_{\text{ocn}}$ in the winter.

IV. Transitional:- The central south-eastern seaboard of Australia, extending north and south of Sydney, can be classified by this regime. It receives a more consistent rainfall than the arid tropical/subtropical regions, but river flow to bays and estuaries is low in the winter months. Typically, estuaries exhibit $S_{\text{syst}} < S_{\text{ocn}}$.

V. Wet Temperate:- A large proportion of Australians live on this coastal region (including inhabitants of Melbourne and Hobart). The region includes most of south-eastern Australia and Tasmania. It also typifies the North Island and the northern part of the South Island of New Zealand, and including its most populous city, Auckland. The estuaries typically yield a land-to-ocean gradient in salinity ($S_{\text{syst}} \ll$ to $< S_{\text{ocn}}$), and may be considered freshwater dominated.

VI. Dry Temperate:- Includes the region of the Great Australian Bight, containing two large gulfs, numerous smaller embayments, and the South Australian city of Adelaide. Virtually no surface runoff and little groundwater reach the coast. Hence, estuaries show $S_{\text{syst}} > \text{to } \gg S_{\text{ocn}}$.

VII. Mediterranean:- Contains much of the southern and western margin of Australia, and includes the city of Perth. These areas receive precipitation in the winter months and very little rainfall during the rest of the year. Estuaries show seasonal changes in salinity gradients with $S_{\text{syst}} < S_{\text{ocn}}$ during May through October, and $S_{\text{syst}} > S_{\text{ocn}}$ during the evaporative summer months.

VIII. Dry Tropical/Subtropical:- Typical of the northwest of Australia, and is extremely dry, with rare precipitation largely associated with monsoonal cyclones. Population density is very low, with no major cities. This area is typically dominated by $S_{\text{syst}} > S_{\text{ocn}}$ systems.

This estuarine classifications shows strong linkages with the climate zones defined for the Australian interior (Figure II.1). Moreover, there are important anthropogenic modifications to the pattern outlined. Because most of the Australian interior is relatively very arid, and because much Australian land use involves extensive irrigation, natural flow of Australian river systems tends to have been greatly modified. Flow in some river systems is lowered, in some cases, dramatically below natural flow. This is particularly true during base flow conditions, although major floods can still deliver large water discharges. Secondly, flow in major river systems is strongly regulated.

It follows that an evaluation of coastal systems of Australia must include not only the climate linkages, but also consideration of land use in the river drainage basins and locations of major population centres.

REFERENCES

- Bucher, D. and Saenger, P. 1991 An inventory of Australian estuaries and enclosed marine waters: an overview of results. *Australian Geographical Studies* **29**, 370-381.
- Eyre, B.D. 1998 Transport, retention and transformation of material in Australian estuaries. *Estuaries* **21**, in press.
- Gordon, D.C. Jr., Boudreau, P.R., Mann, K.H., Ong, J.-E., Silvert, W.L., Smith, S.V. Wattayakom, G., Wulff, F. and Yanagi, T. 1996 LOICZ Biogeochemical Modelling Guidelines. *LOICZ/R&S/ 95-5*, LOICZ, Texel, The Netherlands.

APPENDIX III **Implications of spatial and temporal variation for LOICZ biogeochemical budgets**

Ian T. Webster, John S. Parslow and S. V. Smith

Introduction

The LOICZ Guidelines for constructing biogeochemical budgets for coastal waters (Gordon *et al.* 1996) concentrate on the simplest case where an estuary or embayment is treated as a single box which is well-mixed both vertically and horizontally, and at steady-state. The Guidelines briefly describe approaches to treating systems with horizontal and/or vertical gradients in salinity, and encourage users to resolve temporal variation in loads and responses where data permit. However, it is not clear what errors might be incurred in failing to resolve spatial and temporal variation, or under what conditions these errors might be unacceptable.

Given that LOICZ wants to develop budgets for as many different coastal systems as possible, it is inevitable that budgets will be developed in systems with relatively sparse data, in which it is not possible in any case to resolve spatial and temporal variation. Even in systems where more data are available, it is not clear what level of spatial and temporal aggregation is desirable. While failure to resolve gradients may introduce systematic bias, attempts to over-resolve gradients may introduce high levels of noise. (In this recent Workshop, some participants aggregated data, and calculated budgets based on annual and system-wide averages, while others attempted budgets with fine spatial and temporal resolution.)

Choosing an “optimal” level of spatial and temporal resolution involves a complex mix of deterministic and statistical issues, and developing a generic, quantitative basis for making this choice will not be straightforward. Here, we make a start by examining the systematic errors involved in neglecting (i.e., averaging) spatial and temporal variation in some types of estuary. We consider in particular the effect of averaging temporal variation in simple well-mixed single-box systems. We consider also the effect of ignoring spatial variation in vertically well-mixed, horizontally varying (1-D, 1-layer) estuaries, and the effect of treating an estuary with a two-layer circulation as a single-box system.

1. Effect of Temporal Averaging Procedure

LOICZ budgets for estuaries are often calculated from measurements representing mean values of freshwater inflows, salinities, and concentrations (Gordon *et al.* 1996).

However, in many of the systems the seasonal variations in these properties may be considerable. For example, in Lake Victoria (an estuary in south-eastern Australia; see Section 2.4) the freshwater inflows during the low flow season in summer/autumn 1989 were mostly less than 1000 ML d⁻¹, whereas winter flows and flows in the following spring were mostly greater than 6000 ML d⁻¹. Salinities responded accordingly. Low discharge salinities were about 25 ppt, but these reduced to less than 15 ppt during the high discharge periods. Here, we consider the effects of assuming that fluxes and exchange coefficients can be calculated from mean yearly values of flows, salinities and

concentrations, rather than from an analysis that accounts for the variability of the system.

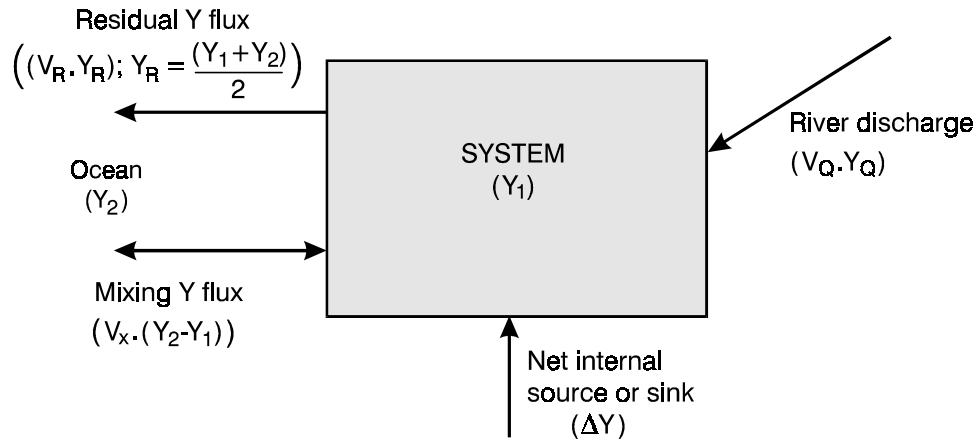

Figure III.1 Schematic of a single-box estuary.

For simplicity, we consider a single-box estuary that exchanges with the sea (Figure III.1). The nomenclature follows that in the LOICZ guidelines (Gordon *et al.* 1996). The estuary has a freshwater inflow, V_Q , which equals the net water exchange with the sea; that is, we assume zero gains or losses due to evaporation, precipitation, groundwater or to another water source within the estuary. Hence, the residual flow to the sea is $V_R = -V_Q$. A mixing exchange occurs with the sea due to winds, tides, or estuarine flow, which is characterised by the exchange velocity V_x . Note that in this analysis, we assume that flows and material transport into an estuary compartment are positive and that outflows are negative. Thus, V_R as depicted in Figure III.1 is negative.

Our hypothetical estuary is subject to two inflow regimes: one of low inflow for part of the year, and the second of elevated inflow for the remainder of the year. The system will be considered to be in quasi steady-state; that is, all flows and concentrations will be time invariant (and in balance) except at the instant that the flow is adjusted to a new level. With these assumptions, the equation for mass conservation in the estuary of a substance with concentration, Y , is:

$$Y_Q V_Q + (Y_2 - Y_1) V_x - \frac{Y_1 + Y_2}{2} V_Q + \Delta Y = 0 \quad (1.1)$$

In this equation, Y_Q , Y_1 , and Y_2 are the concentrations in the river inflow, in the estuary and in the sea respectively. The net internal source or sink of the substance within the estuary is ΔY . In Figure III.1, this source/sink term has been schematised as an internal gain into the water column through the bottom (positive).

This equation can be solved for Y_1 as:

$$Y_1 = \frac{2Y_0V_0 + Y_2(2V_x - V_0) + 2\Delta Y}{2V_x + V_0} \quad (1.2)$$

If the substance is salt, then we can use Eq.1.1 to estimate V_x from measured salt concentrations in the estuary and in the sea. For salt, Y is S , $S_0 = 0$, and $\Delta S = 0$, so:

$$S_1 = \frac{2V_x - V_0}{2V_x + V_0} S_2 \quad (1.3)$$

Let the low-flow regime into the estuary have inflow, V_0^0 and let it pertain for fraction, θ , of the year. The high flow regime has inflow, V_0^+ , and applies for the rest of the year, $(1-\theta)$. We shall specify that the high inflow is R times larger than the low inflow; that is:

$$V_0^+ = R V_0^0 \quad (1.4)$$

and that V_x remains constant through the year and is expressed in terms of V_0^0 as:

$$V_x = r V_0^0 \quad (1.5)$$

The assumption of constant V_x is not generally justifiable and is undertaken for simplicity and for illustrative purposes. One might expect that for very small inflows, estuarine circulation would be weak, and that mixing exchange would be dominated by winds and tides. For intermediate inflows, the estuarine circulation would become relatively stronger, but at very high inflows the estuarine circulation would again weaken as salt is flushed out of the estuary almost completely.

The salinity and other concentrations within the estuary will differ between the low- and high-inflow regimes. From Eqs. 1.3-1.5, the salinities in the low and high-flow regimes are calculated as:

$$S_1^0 = \frac{2V_x - V_0^0}{2V_x + V_0^0} S_2 = \frac{2r - 1}{2r + 1} S_2 \quad (1.6)$$

$$S_1^+ = \frac{2V_x - V_0^+}{2V_x + V_0^+} S_2 = \frac{2r - R}{2r + R} S_2 \quad (1.7)$$

The ocean salinity, S_2 , has been assumed to be constant through the year. In effect, S_1^0 and S_1^+ are the estuarine salinities that would occur for our assumed flow regimes, ocean salinity, and exchange flow speeds.

The average salinity through the year is calculated from Eqs. 1.6 and 1.7 as:

$$\begin{aligned}\bar{S}_1 &= \theta S_1^0 + (1-\theta)S_1^+ \\ &= \alpha S_2\end{aligned}\quad (1.8)$$

where:

$$\alpha = \theta \frac{2r-1}{2r+1} + (1-\theta) \frac{2r-R}{2r+R} \quad (1.9)$$

Similarly, the yearly averaged inflow into the estuary is:

$$\begin{aligned}\bar{V}_Q &= V_Q^0 + (1-\theta)V_Q^+ \\ &= \beta V_Q^0\end{aligned}\quad (1.10)$$

with:

$$\beta = \theta + (1-\theta)R \quad (1.11)$$

As is most often done, we use the average values of the estuarine salinity and inflow to calculate the estuarine mixing flow. From Eq. 1.1, the mass balance equation for salt is written as:

$$(S_2 - \bar{S}_1)\bar{V}_x - \frac{\bar{S}_1 + S_2}{2}\bar{V}_Q = 0 \quad (1.12)$$

from which:

$$\bar{V}_x = \frac{\bar{S}_1 + S_2}{2(S_2 - S_1)}\bar{V}_Q \quad (1.13)$$

Substitution for \bar{S}_1 and \bar{V}_Q from Eqs. 1.8 and 1.10 gives:

$$\bar{V}_x = \gamma W_Q^0 \quad (1.14)$$

where:

$$\gamma = \frac{\alpha\beta + \beta}{2(1-\alpha)} \quad (1.15)$$

However, the ‘true’ V_x is equal to rV_o^0 , but in general $\gamma \neq r$. Averaging salinities and inflows for calculating V_x results in an error in estimating this mixing flow.

The salinity budget allows calculation of V_x , but we really want to know the effects of averaging on the estimation of fluxes of substances other than salt. For simplicity, we shall assume that the concentration of the substance in the inflow is constant through the year. Thus, the input load to the estuary is proportional to the magnitude of the inflow. We shall also assume that the marine concentration of the substance being considered is low enough that we can set $Y_2 = 0$. With these assumptions, Eq. 1.1 becomes:

$$Y_1 = \frac{2Y_oV_o + 2\Delta Y}{2V_x + V_o} \quad (1.16)$$

The internal gain term is assumed to be constant and is expressed as a fraction, ϕ , of the input load under low flow conditions; that is:

$$\Delta Y = \phi Y_o V_o^0 \quad (1.17)$$

Using Eqs. 1.4, 1.5, 1.16 and 1.17, we calculate Y_1 under low and high inflow conditions in analogous fashion to the calculation of S_1^0 and S_1^+ using Eqs.1.6 and 1.7:

$$Y_1^0 = 2Y_o \frac{1+\phi}{2r+1} \quad (1.18)$$

$$Y_1^+ = 2Y_o \frac{R+\phi}{2r+R} \quad (1.19)$$

Averaging the concentration over the year gives:

$$\begin{aligned} \bar{Y}_1 &= \theta Y_1^0 + (1-\theta) Y_1^+ \\ &= \psi Y_o \end{aligned} \quad (1.20)$$

where:

$$\psi = 2\theta \frac{1+\phi}{2r+1} + 2(1-\theta) \frac{R+\phi}{2r+R} \quad (1.21)$$

As we did using average salinity and inflow to calculate V_x , we can use the average inflow, \bar{V}_x , and estuarine concentration to calculate the average flux. Rearrangement of Eq. 1.1 gives:

$$\bar{\Delta Y} = -Y_o \bar{V}_o + \bar{Y}_1 \bar{V}_x + \frac{\bar{Y}_1 \bar{V}_o}{2} \quad (1.22)$$

After substituting for \bar{V}_o (Eq. 1.10), \bar{Y}_1 (Eq. 1.20), and \bar{V}_x (Eq. 1.13), we obtain:

$$\bar{\Delta Y} = (-\beta + \gamma\psi + \frac{\beta\psi}{2})Y_oV_o^0 \quad (1.23)$$

The 'true' flux is $\bar{\Delta Y} = \phi Y_oV_o^0$ so that the relative size of the estimated flux to the true flux is:

$$\begin{aligned} \frac{\bar{\Delta Y}}{\Delta Y} &= (-\beta + \gamma\psi + \beta\psi/2) / \phi \\ &= \frac{(\theta + R - \theta R)(\theta R + 2r + 1 - \theta)}{2rR + R + 2\theta R - 2\theta rR} \end{aligned} \quad (1.24)$$

after substitution for β , γ , and ψ . Note that $\bar{\Delta Y} / \Delta Y$ is not a function of the size of the internal gain term.

Evaluation of Eq. 1.24 shows that $\bar{\Delta Y} / \Delta Y$ has its largest values when $\theta \sim 0.5$; that is, when the low- and high-inflow regimes are of similar period. When the flow regime approaches the limits of being all low inflow ($\theta = 1$) or all high inflow ($\theta = 0$), the error in the estimation of ΔY approaches zero. Figure III.2 shows $\bar{\Delta Y} / \Delta Y$ as a function of r and R when $\theta = 0.5$. Thus, the Figure shows approximately the largest error that is obtained due to temporal averaging. The results have been plotted for $r > R/2$ since for

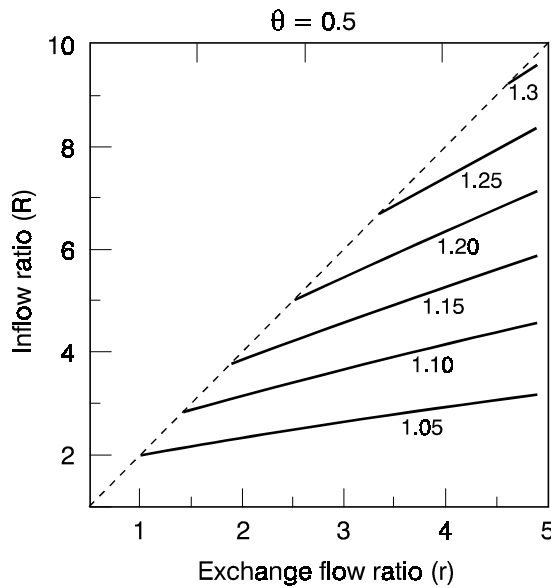

Figure III.2 Contours of $\bar{\Delta Y} / \Delta Y$ plotted versus the ratio of inflow magnitudes and the exchange flow ratio for $\theta = 0.5$. (Zone above dashed line is physically unreasonable.)

smaller values of R , S_1^+ would be negative (Eq. 1.7) which is physically impossible. The relative error increases as r decreases and as R increases; that is, the error is largest for estuaries that are still relatively fresh during the time of low inflow and for those subject to a large change in river inflow through the year. When $r = 1.25$, which is the value calculated when $S_1 = 0.5S_2$, the over-estimation of ΔY is 8% at $R = 2.5$, its maximum value. For $S_1 = 0.8S_2$, $r = 4.5$ and the over-estimation of ΔY reduces to 3% at $R = 2.5$. For this value of r , the maximum over-estimation of ΔY is 30% which occurs when $R = 9$.

The fundamental problem with estimating fluxes using Eq.1.22 lies in the invalidity of the averaging used to form this equation from Eq. 1.1. Rather than using Eq.1.22 to estimate the internal gain/loss, we should use:

$$\overline{\Delta Y} = -\overline{Y_0 V_0} + \overline{Y_1 V_x} + \frac{\overline{Y_1 V_0}}{2} \quad (1.25)$$

In this equation, the terms are the averages of the products of concentrations and flows rather than the products of the averages of these quantities.

2. *Effects of Horizontal Averaging*

We are interested in the effects on the calculated budgets (and the estimated internal sources and sinks in particular) of averaging along spatial gradients in estuaries which are vertically and transversely well-mixed, but have classical long-estuary mixing gradients of salinity and other tracers. We assume that the estuary is at steady-state, and that salinity (S) and another tracer (Y) are functions of the long-estuary coordinate, x ; that is, $S = S(x)$ and $Y = Y(x)$. Also, we assume that enough samples of S and Y are taken to compute volume-weighted averages $S_1 = \langle S \rangle$ and $Y_1 = \langle Y \rangle$ for the estuary. Suppose the fresh-water runoff into the head of the estuary is V_0 , that the marine salinity is S_2 as in Figure III.1, and that the marine concentration of tracer Y is zero ($Y_2 = 0$).

Applying the LOICZ Guidelines, we would compute a mixing exchange V_x between the estuary and the ocean given by:

$$V_x = \frac{\langle S \rangle + S_2}{2(S_2 - \langle S \rangle)} V_0 \quad (2.1)$$

by analogy with Eq. 1.13.

We then calculate a net export of tracer Y from the estuary to be:

$$F_Y = \frac{\langle Y \rangle V_0}{2} + \langle Y \rangle V_x \quad (2.2)$$

Given a known load of Y , L_Y , we would calculate an internal source ΔY given by:

$$\Delta Y = F_Y - L_Y \quad (2.3)$$

The question here is how the calculated export relates to the real export, and how this affects the estimated internal source. This obviously depends on the mixing and cycling of Y within the estuary. We consider here the special case where the tracer Y is conservative, and the load of Y is all due to a single-point source of Y at location x^* , and salinity S^* .

We can think of this special case in two ways. In many urban estuaries, there is a large point source of nitrogen and phosphorus located at some point along the estuary. This analysis then shows directly the bias that would be incurred by trying to estimate the fate of N and P from that source while ignoring the long-estuary gradient and source location. However, the analysis has a broader interpretation. In principle, we can describe the dynamics of any non-conservative tracer as corresponding to that of a conservative tracer with a source term $Q(x)$ distributed along the estuary. A LOICZ budget based on averaged concentrations will produce an estimate of the total source ΔY , which is a weighted average $\int wQ dx$. The analysis here shows how the weight $w(x)$ varies along the estuary.

For a conservative tracer, Y , in a one-dimensional estuary, it can be shown (Officer 1979) that the downstream flux of Y at any point x and salinity S is given by:

$$F(x) = V_Q \left(Y - S \frac{dY}{dS} \right) \quad (2.4)$$

Given the load L_Y at point x^* , salinity S^* , it follows from this equation that downstream of x^* , $F_Y = L_Y$ (constant), and:

$$Y = \frac{L_Y(1 - S / S_2)}{V_Q} \quad (2.5)$$

Upstream of x^* , $F_Y = 0$, and:

$$Y = \frac{L_Y S(1 - S^* / S_2)}{S^* V_Q} \quad (2.6)$$

Examples of these concentration distributions are shown in Figure III.3. Note that the tracer concentration downstream of the source is independent of the source location, but the peak tracer concentration, $(L_Y / V_Q)(1 - S^* / S_2)$, declines to zero as the point source is located further downstream and S^* approaches S_2 . This reflects the increase in “effective” flushing rate as we approach the mouth of the estuary.

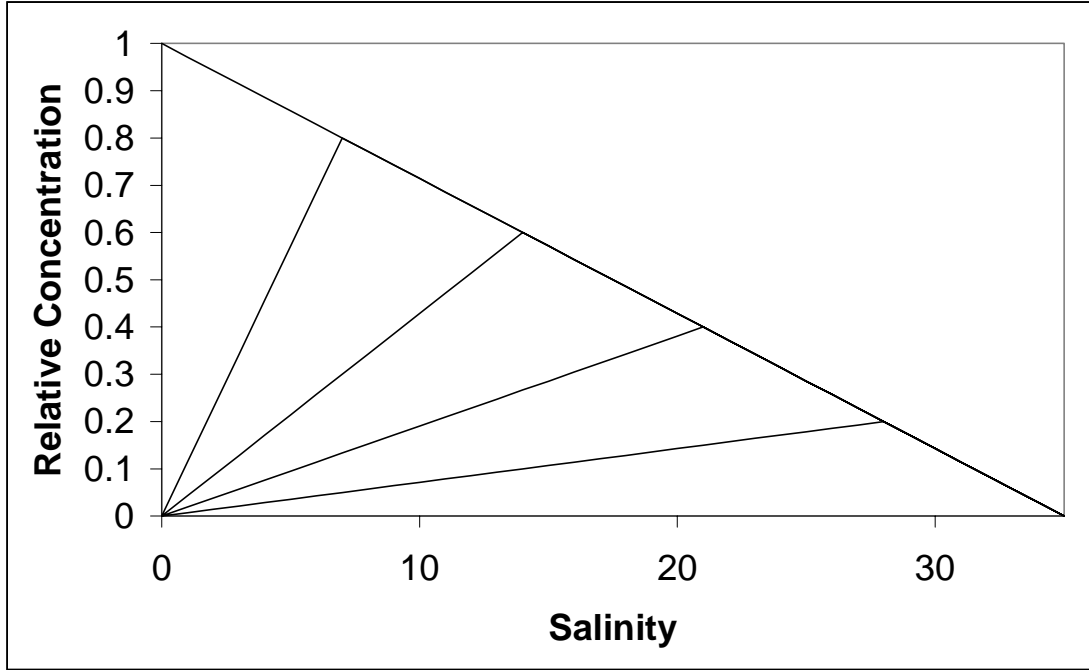

Figure III.3 Relative concentration vs salinity for a conservative tracer with fixed load located at salinity $S^* = 0, 7, 14, 21, 28$.

It is obvious from Figure III.3 that the average concentration, $\langle Y \rangle$, diminishes as the source is located closer to the mouth. Because $\langle Y \rangle$ is a volume-weighted average, we need to make further assumptions about the distribution of $S(x)$ and cross-section area $A(x)$ in order to compute $\langle Y \rangle$ as a function of x^* . We consider two cases. The first assumes a channel with constant cross-section and a linear increase in S with x , so that a volume-weighted average is the same as a salinity-weighted average. Then, from integration of Eqs. 2.5 and 2.6:

$$\langle Y \rangle = \frac{L_Y(1 - S^*/S_2)}{2V_Q} \quad (2.7)$$

As $\langle S \rangle = S_2/2$, $V_x = 1.5V_Q$ (from Eq. 2.1), and the LOICZ (single-box) export is:

$$F_Y = L_Y(1 - S^*/S_2) \quad (2.8)$$

so:

$$\Delta Y = -\frac{L_Y S^*}{S_2} \quad (2.9)$$

In other words, if a known external load of a conservative tracer occurs at the head of the estuary, the single-box (spatially-averaged) budget will correctly estimate the export, and correctly conclude that there is no internal sink. However, if this load is discharged at

some point along the estuary with salinity S^* , the spatially-averaged budget will underestimate the export by a factor $(1 - S^* / S_2)$, and incorrectly conclude that there is a large internal sink. As the source location approaches the mouth of the estuary, this false sink will approach 100% of the load. If there is a natural sink or source within the estuary, this sink or source will be under-estimated in the budget by the same factor $(1 - S^* / S_2)$. A natural sink, which is uniformly distributed along the length of the estuary, will be under-estimated by 50%.

The assumptions of constant channel width and linear decline in S with x are not very realistic. For a more realistic configuration, consider an estuary of length x_L , where the cross-section area increases linearly with x as $A = \mu x$. Suppose $\lambda = V_Q / \mu D$ where the long-estuary diffusivity, D ($\text{m}^2 \text{s}^{-1}$), is constant. Then, it is possible to show that $S = S_2(x / x_L)^\lambda$, and:

$$\langle S \rangle = \frac{S_2}{2(\lambda + 2)} \quad (2.10)$$

and:

$$\langle Y \rangle = \frac{L_Y \lambda (1 - S^{*2} / S_2^2)}{V_Q (\lambda + 2)} \quad (2.11)$$

Applying a single-box LOICZ budget gives:

$$F_Y = L_Y (1 - S^{*2} / S_2^2) \quad (2.12)$$

Once again, if the source is located downstream of the head of the estuary, the single-box budget underestimates the export, and will incorrectly conclude that there is an internal sink. In this case, the error is smaller for a given value of S^* but still approaches 100% as S^* approaches S_2 . Alternatively, if there is a natural internal sink distributed uniformly throughout the estuary which takes up Y at a fixed rate per unit area of bottom, then the single-box budget will underestimate this sink by a factor $\lambda / (\lambda + 1)$.

These errors are potentially large enough to badly distort budgets and, where there are large point sources located along the estuary, will render any estimates of internal sources or sinks meaningless. The examples are idealised, especially in the assumption that there are sufficient data to compute volume-weighted averages. In a more typical case where a single-box budget is calculated, there may be only a few measurements over the length of the estuary. Budgets are then subject to additional uncertainty depending on how these observations sample the long-estuary gradients.

If there are sufficient data to resolve long-estuary gradients, the bias involved in single-box budgets can in principle be avoided by computing spatially-resolved budgets. However, this may introduce other kinds of errors. According to Officer's result above,

the net export from the mouth of the estuary is controlled by the gradient dY/dS , at the mouth of the estuary. However, long-estuary gradients of Y and S may be weak near the mouth, and subject to considerable local spatial and temporal variability, making estimates of the gradient dY/dS highly uncertain. Caution must be exercised in choosing spatial compartments (i.e., salinity intervals) which are large enough to provide adequate signal-to-noise in flux estimates.

3. Effects of Vertical Averaging

Dyer (1973) has classified estuaries into three general types depending on salinity – highly stratified, vertically homogeneous, and partially mixed. Both the highly stratified and partially mixed estuaries are characterised by having a two-layer flow. An upper layer, which is relatively fresh, flows seaward and overlies a more saline lower layer. Mixing and entrainment across the boundary between the two layers causes the surface layer to become more saline as it flows towards the mouth. The salt transported towards the sea in the surface layer is replaced by a landward flow in the lower layer. Pritchard (1969) developed a model for transport in such a two-layer system that allowed for the estimation of entrainment and mixing between the layers from conservation of salt and water. Wulff and Stigebrandt (1989) used such an analysis to derive nutrient budgets for a series of three basins connected in series through the Baltic Sea starting with Bothnian Bay. An analysis extended by two additional basins to the Kattegat is described in Gordon *et al.* (1996).

a) Two-layer case

Here, we address the question of how treatment of an estuary as a single box differs from treatment of an estuary as having an upper and a lower layer, from the standpoint of budget calculations. The two-layer estuary we consider is schematised in Figure III.4. Exchange between the upper and lower layers occurs through the entrainment term $V_e \cdot (Y_{ld} - Y_{lu})$ and through the mixing term $V_m \cdot (Y_{lu} + Y_{ld})/2$, Y_{lu} and Y_{ld} being the concentrations in the upper and lower layers, respectively. Freshwater discharges into the upper layer at rate V_Q and there is assumed to be no internal loss or addition to the inflow in either layer. Thus the water budget is expressed as:

$$V_Q + V_u + V_d = 0 \quad (3.1)$$

where V_u and V_d are the inflows/outflows to the upper and lower layers. The terms ΔY_u and ΔY_d are net internal sources or sinks of the substance within the upper and lower layers. As before, we define all material flows as being positive for flows into an estuary compartment except for the entrainment flow, V_e , which is positive for a flow from the lower to the upper layer.

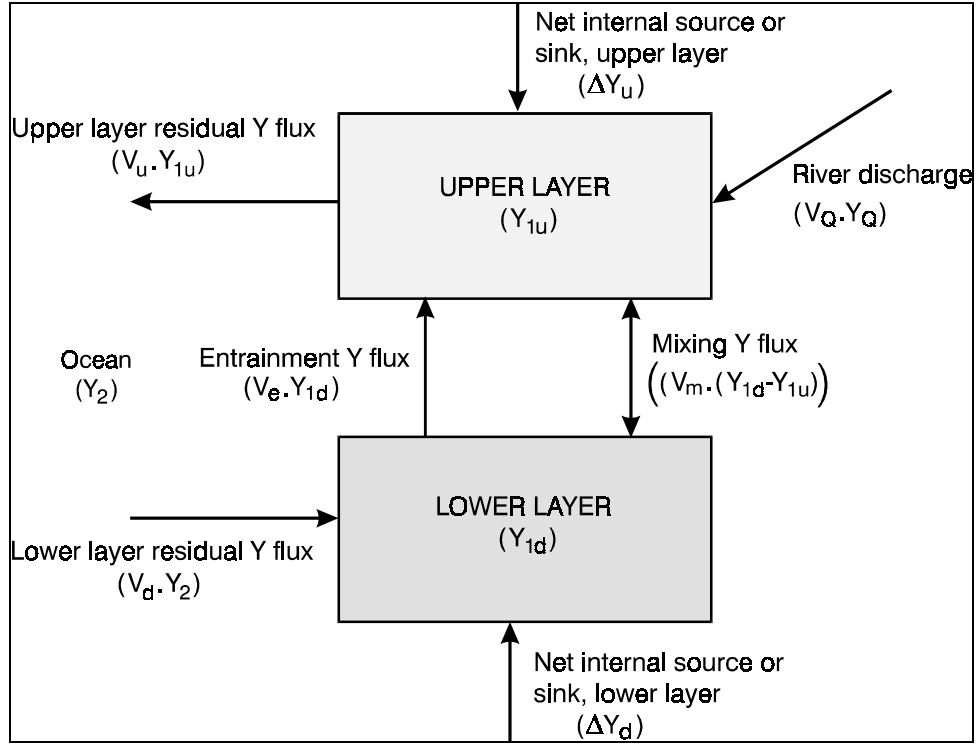

Figure III.4 Schematic of a two-layer estuary.

The material budgets for the upper and lower layers are:

$$Y_Q V_Q + Y_{1u} V_u + Y_{1d} V_e + (Y_{1d} - Y_{1u}) V_m + \Delta Y_u = 0 \quad (3.2)$$

$$Y_2 V_d - Y_{1d} V_e - (Y_{1d} - Y_{1u}) V_m + \Delta Y_d = 0 \quad (3.3)$$

If we add Eqs. 3.2 and 3.3 and use Eq. 3.1 to eliminate V_d , we obtain:

$$Y_Q V_Q + Y_{1u} V_u + Y_2 (-V_Q - V_u) + \Delta Y_u + \Delta Y_d = 0 \quad (3.4)$$

As in section 1, we obtain an equation for the salt balance by setting Y to be S , $S_Q = 0$, and $\Delta S = 0$. Solving Eq. 3.4 for the advective outflow in the upper layer gives:

$$V_u = \frac{S_2}{S_{1u} - S_2} V_Q \quad (3.5)$$

It is convenient to define non-dimensional variables denoted with a prime using:

$$S' = \frac{S}{S_2}; \quad V' = \frac{V}{V_Q}; \quad Y' = \frac{Y}{Y_Q} \quad (3.6)$$

Thus:

$$V_u' = \frac{1}{S_{1u}' - 1} \quad (3.7)$$

For the calculation of internal gain/loss from the estuary, we will assume that $Y_2 = 0$ as in section 1. Upon rearrangement of Eq. 3.4 and with the use of the non-dimensionalisation expressions, Eq. 3.6, we obtain:

$$\Delta Y_u + \Delta Y_d = -(1 + Y_{1u}' V_u') Y_Q V_Q \quad (3.8)$$

b) Single-box case

The case of a single box has already been considered in section 1, and we follow the analysis developed there. For the two-layer estuary, we have assumed that the salinities in the two layers are S_{1u} and S_{1d} (Figure 1). The equivalent salinity for the single-box estuary (assuming that the two layers have equal volume) would be the average of the salinities in the two layers; that is:

$$S_1 = \frac{S_{1u} + S_{1d}}{2} \quad (3.9)$$

and similarly the equivalent single-box concentration would be:

$$Y_1 = \frac{Y_{1u} + Y_{1d}}{2} \quad (3.10)$$

For the single-box analysis presented here, the equations for the exchange flow and for the internal gain/loss follow are the same as Eqs. 1.13 and 1.22 without the temporal averaging operators. The present case is time invariant. Thus:

$$V_x = \frac{S_1 + S_2}{2(S_2 - S_1)} V_Q \quad (3.11)$$

or, with Eq. 3.9, we obtain:

$$V_x = \frac{(S_{1u} + S_{1d})/2 + S_2}{2(S_2 - (S_{1u} + S_{1d})/2)} V_Q \quad (3.12)$$

Substitution of the non-dimensionalisation expressions, Eq. 3.6, yields:

$$V_x' = \frac{S_{1u}' + S_{1d}' + 2}{2(2 - S_{1u}' - S_{1d}')} \quad (3.13)$$

For the steady-state system we consider here, the internal gain/loss for a single-box

estuary is obtained by rearranging Eq. 1.1 as:

$$\Delta Y = -Y_Q V_Q + Y_1 V_x + \frac{Y_1 V_Q}{2} \quad (3.14)$$

This equation is the same as Eqs. 1.22 and 1.25 without the temporal averaging overbar. Substitution of Eq. 3.10 for Y_1 and use of Eq. 3.6 to non-dimensionalize the variables allows calculation of the internal gain/loss for the single-box equivalent of a two-layer estuary to be:

$$\Delta Y = (-1 + (Y'_{1u} + Y'_{1d})(1/4 + V'_x/2))Y_Q V_Q \quad (3.15)$$

c) Comparison of cases

Figure III.5 shows the total internal gain/loss as functions of the upper and lower layer concentrations of substance Y for the single-box case (Eq. 3.15) non-dimensionalised by the input load, $Y_Q V_Q$ as:

$$\Delta Y'_1 = \frac{\Delta Y}{Y_Q V_Q} \quad (3.16)$$

The results have been shown for an upper layer salinity of $S'_{1u} = 0.25$ and a lower layer salinity of $S'_{1d} = 0.75$. These would correspond to the case of a partially mixed estuary.

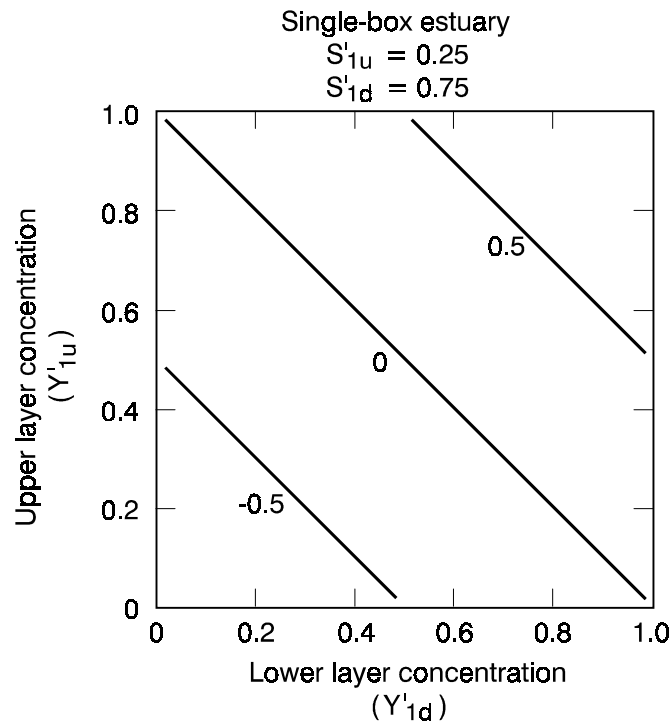

Figure III.5 Contours of ΔY_1 plotted against non-dimensional concentrations in upper and lower layer for the single-box estuary.

Of course, for the single-box estuary, the exchange to the sea and the calculation of internal gain/loss depend only on the average of the upper and lower layer salinities and concentrations. Accordingly, the isolines of the internal gain/loss function are the lines of constant $Y_{1u} + Y_{1d}$. For the chosen salinities, $\Delta Y_1'$ is negative when the estuarine concentration is less than the concentration in the inflow, but it is positive if the estuarine concentration is greater. The position of the isoline of zero internal gain depends on the average salinity. As the average salinity increases, $\Delta Y_1'$ also increases for fixed estuarine concentration.

Similarly, Figure III.6 shows the internal gain/loss for the two-layer case (Eq. 3.8) non-dimensionalised in the same way:

$$\Delta Y_2' = \frac{\Delta Y_u + \Delta Y_d}{Y_Q V_Q} \quad (3.17)$$

Clearly, the isolines of internal gain/loss for the two-layer case are very different from those determined for the single-box estuary. For the two-layer case, the isolines are horizontal, whereas for the single-box case they are diagonal. This result demonstrates that, even for the same salinity and concentration assumptions being made, the calculated internal gain/loss is critically dependent on the configuration chosen to represent the estuary.

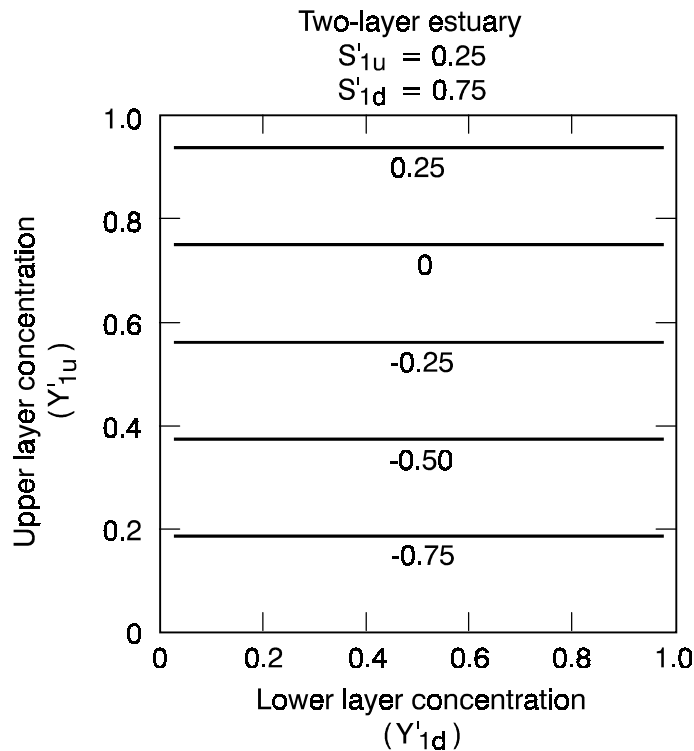

Figure III.6 Contours of $\Delta Y_1'$ plotted against non-dimensional concentrations in upper and lower layer for the two-layer estuary.

As an example, suppose the upper layer salinity (non-dimensional) is 0.25 and the lower layer salinity is 0.75. Further suppose that the measured upper and lower layer concentrations are both 0.5. Then, Figure III.5 tells us that the inferred internal loss would be 0 using the single-box analysis. However, Figure III.6 tells us that internal loss would be about 0.3 ($\Delta Y_2' \sim -0.3$) if the calculation were obtained using the two-layer representation.

We have already pointed out that for the single-box estuary the internal gain/loss is a function of the sum of the upper and lower layer concentrations. However, the two-layer case has the internal gain/loss to be a function of the salinity and concentration in the upper layer only (Eqs. 3.7 and 3.8). Of course, if the concentration of substance (not salt) is non-zero in the sea, then that concentration will enter the calculation of internal gain/loss as well.

The difference in calculated internal gain/loss between the two representations of estuaries arises from different fundamental assumptions about how the along-estuary solute transport occurs. In the single-box estuary, the advective flow out of the estuary carries with it a concentration halfway between oceanic and estuarine concentration. In a real estuary, the concentration at the seaward boundary of the box would be such if horizontal mixing within the estuary were vigorous. In this situation, we would expect that vertical gradients of salt and other solutes would be small. Consequently, the single-box representation is likely to be most appropriate to vertically homogeneous estuaries. The fundamental mixing dynamic represented in the two-layer representation is quite different. The surface-layer flow out of the estuary has a concentration equal to that near the center of the estuary. In other words, there is an implicit assumption that the amount of dilution of the seaward-flowing surface layer by horizontal mixing with ocean water is small. The two-layer representation is likely to be best for highly stratified estuaries.

REFERENCES

- Gordon, D.C. Jr., Boudreau, P.R., Mann, K.H., Ong, J.-E., Silvert, W.L., Smith, S.V. Wattayakom, G., Wulff, F. and Yanagi, T. 1996 LOICZ Biogeochemical Modelling Guidelines. *LOICZ/R&S/95-5*, LOICZ, Texel, The Netherlands.
- Pritchard, D.W. 1969 Dispersion and flushing of pollutants from estuaries. *Proceedings of the American Society of Civil Engineers* **95**, HY1: 115-124.
- Wulff, F. and Stigebrandt, A. 1989 /a time-dependent budget model for nutrients in the Baltic Sea. *Global Biogeochemical Cycles* **3**: 63-78.

APPENDIX IV BUDGETS ESTIMATES BY NON-LOICZ APPROACHES

**APPENDIX IVA RICHMOND RIVER ESTUARY (NEW SOUTH WALES):
INTER-ANNUAL BUDGETS FROM SEASONAL AND
EVENT MONITORING; A MODIFIED LOICZ
APPROACH.**

L. McKee and B.D. Eyre

Study Area Description

The Richmond River estuary is a sub-tropical shallow bar built system (Figure IV.1; also Figure 1.1)



Figure IV.1 Richmond River estuary, New South Wales.

During the driest part of the year (September) the estuary is well mixed and ocean salt penetrates 40-50 km upstream. In the wet season the Richmond estuary can be flushed fresh to the mouth for up to several weeks each time heavy rain occurs in the catchment. The estuary has a surface area of 15 km², a surface catchment:estuary area ratio of 449, an average volume of about 54 million m³, and a semi-diurnal tidal cycle. The tidal range varies from a minimum of 0.65 m on neap tides to a maximum of 1.9 m on spring tides. Average coastal rainfall varies from 1300 mm at Woodburn to 1800 mm at Ballina and rainfall has a seasonal late-summer dominated pattern. The estuary receives the majority of its freshwater discharge (annual average = 11.7 L s⁻¹ km⁻²) from the Richmond catchment above Woodburn which comprises 87% of the total catchment area (6861 km²). Discharge during the study varied between 0.29 - 376 L s⁻¹ km⁻² resulting in estuarine flushing times from <1d to 176d. For the purpose of this study, the estuary is defined as the area downstream from Coraki (the maximum limit of salt intrusion during the dry season).

Sediment organic carbon ranges from 1% near Ballina to 14% in the upper reaches (Woodburn). The dominant producer in the system is unknown but is assumed to be phytoplankton. However, the lower reaches are lined by riparian mangroves and there are small areas of seagrasses in shallow protected areas of the lower estuary. The main land uses in the coastal plain include sugar cane, beef farming, urban, and scattered rural residential areas. The upper catchment, which supplies the majority of the freshwater to the system, has 41% forest cover, 53% dairy and beef grazing, and 6% cropping and horticulture. The average population density for the catchment is 14 persons km⁻² of which 61% live in urban areas. There is one sewage treatment plant (STP) discharging into the lower Richmond River estuary at Ballina.

Methods

Diffuse loads

N and P concentrations derived from water samples collected on a flow-weighted basis from all terrestrial sources were combined with discharge on a monthly basis during low flow periods, and on an hourly basis during floods, using linear interpolation between samples. Loads from the upper catchment, coastal sub-catchment and cane land were added to give a total diffuse load to the estuary.

Atmospheric loads

N and P concentrations derived from precipitation samples gathered during rain events were combined with rainfall volume entering the estuary surface.

Sewage load

Nutrient loads via leaching from septic systems adjacent to the estuary were estimated using loads of TN (4 kg person⁻¹ yr⁻¹) and TP (1 kg person⁻¹ yr⁻¹) and applying these to the unsewered townships of Wardell and Broadwater adjacent to the estuary. The loads calculated are probably an over-estimate because it was assumed that all TN and TP from septic systems reached the estuary. The load of urban sewage from Ballina was estimated by integrating metered discharges and monthly average concentrations of

nitrate, ammonia, and total phosphorus obtained from local authorities. Loads from leaching and treated sewage were combined to give a total sewage input.

Loads from urban runoff

Nitrogen loads associated with urban runoff were calculated by multiplying average TN concentration (1.4 mg L^{-1}) found in Lismore urban drains (the largest town in the Richmond River catchment) (C_{Urb}) by monthly rainfall at Lismore (R) and impervious area (A_{Imperv}), using a runoff coefficient of 50%, and summing from July to June for each year of the study:

$$\text{Load}(\text{kg yr}^{-1}) = \sum_{\text{Jul}}^{\text{Jun}} C_{\text{Urb}} 0.5RA_{\text{Imperv}}$$

Phosphorus loads were calculated similarly, using a TP concentration of 0.7 mg L^{-1} . Loads from the coastal towns of Ballina, Wardell, Broadwater, Woodburn, and Coraki were estimated by the ratio of each town's population to the population of Lismore, in the absence of nutrient concentration data for small towns adjacent to the estuary.

Estuarine 24 hour sampling

Water samples were collected at approximately 1.5 hour intervals over 23-26 hours during consecutive spring and neap tides at Ballina (Figure IV.1). Sampling was carried out over a range of catchment discharges on five occasions between July 1994 and June 1996. Water samples and velocity measurements were taken at three depths at three points across the estuary mouth (which has been modified to a rectangular cross-section for shipping purposes).

Each transect was echo-sounded to obtain cross-sectional area profiles. This area was adjusted for tidal fluctuations over each sampling period to give a cross-sectional area at a given time during each survey. Discharge for each transect was calculated by multiplying the average velocity in a vertical section (three sub-sections) by the sectional area (adjusted for tide height). Total discharge (m^3) was calculated by summing the sub-sections and multiplying by the time between samples (usually 1.5 hours). Nutrient loads for each tide at Ballina were calculated by multiplying the sample concentration (mg L^{-1}) by discharge (m^3) for each 1.5 hour period and summing over the full tidal cycle (25 hours).

Flood event sampling at the mouth

Sampling was undertaken on three occasions during flood events when the estuary was flushed fresh to the mouth at Ballina. Water samples were taken up to 4 times a day. Logistical difficulties did not allow the direct measurement of velocity. Instead, velocity and discharge were modelled (Hossain 1998), using the one-dimensional unsteady flow model (DUFLOW). Nutrient loads during the flood events were calculated, using the same methods described for tidal sampling. Mass loads for the rest of each month when a flood event occurred, were calculated by multiplying modelled discharge by the nutrient concentration of the last sample taken during flood event sampling.

Nutrient load verses discharge relationships for the estuary at Ballina

Loads calculated for months with storm discharge and loads derived from 24-hour sampling were used to develop rating relationships between catchment discharge and load. Variation in catchment discharge accounted for greater than 98% of the variation in nutrient loads. The rating relationships were used to predict the loads during periods when sampling was not undertaken.

Sediment nutrients

Samples were collected on three occasions for analysis of sediment nitrogen and phosphorus. The top 2-4 cm of sediment were grab-sampled from depositional areas below low tide level, near the edge of the estuary, at 13 locations. Loads of nutrients stored in the estuarine sediments were estimated by multiplying net sedimentation rates (Hossain 1998) for the 1994/95 year (5423 tonnes upper estuary, 12 497 tonnes lower estuary) and for the 1995/96 year (4664 tonnes upper estuary, 9256 tonnes lower estuary), by the average sediment nutrient composition (upper: 2.0 kg N t⁻¹, 0.9 kg P t⁻¹, lower: 0.9 kg N tonne⁻¹, 0.5 kg P tonne⁻¹).

Errors

Errors for each term in the nutrient budgets were relatively small when considered separately. However, the errors associated with the residual in the N budget incorporated the additive errors of all the other terms. Included were the errors associated with sediment and water column nutrient analysis, catchment discharge, calibration of the hydrodynamic model, and sedimentation rates. Unknown errors associated with the measurement of sewage loads, urban runoff, and precipitation were assigned the same error as that of the diffuse loads. Since these loading terms were small relative to ocean exchange and diffuse runoff, this approximation is of little consequence to the overall interpretation. The errors were then summed to give a total error for the residual of the TN budget. In the case of the stoichiometrically linked TDN and TDP budgets, the error assigned to the unknown term (*nfix-denit*) was calculated as the sum of the TDN errors and 16 times the sum of the TDP errors.

Results

Water Budget

The Richmond River estuarine water budget is driven mainly by catchment discharge (Figure IV.2). The majority (70-90%) of the annual catchment discharge can occur during short-lived events associated with tropical rain depressions. If rainfall minus evaporation over the estuary is assumed to be small (reasonable for an average year), the discharge through the mouth is assumed to be equivalent to the catchment discharge. The water budgets are presented simplistically (Figure IV.2); however, the catchment discharge and the estuarine water exchange through the mouth were quantified for the system using rainfall runoff relationships, a one-dimensional computer model and an hourly time step (Hossain 1998).

Total nitrogen budget

Annual total nitrogen budgets are presented where the single unknown term can be considered the net N₂ exchange with the atmosphere (Figure IV.3). Using a total

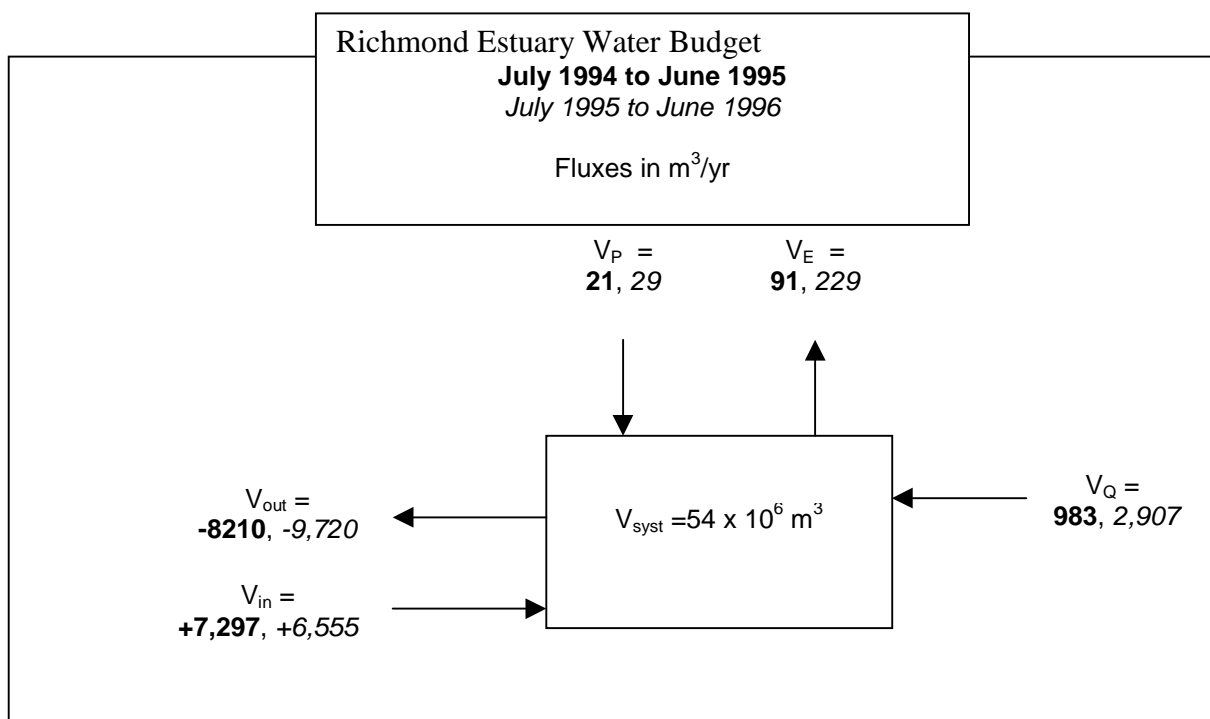

Figure IV.2 Water budget, Richmond River estuary.

nitrogen budget, (*nfix-denit*) rates computed for each year are not distinguishable from zero (Table IV.1). This occurs because the residuals for the annual budgets are small compared with the sum of errors associated with the quantification of the other terms. Therefore, in sub-tropical systems such as the Richmond River estuary, where much of the annual loads are transmitted conservatively through the estuary during wet season floods, annual N budgets are unlikely to allow the calculation of atmospheric N₂ exchange.

Table IV.1 Budget Comparisons, Richmond River estuary.

Budget	(<i>nfix-denit</i>) [Redfield Ratio] mmol m ⁻² d ⁻¹	(<i>nfix-denit</i>) [sediments] mmol m ⁻² d ⁻¹	(<i>p-r</i>) [Redfield Ratio] mmol m ⁻² d ⁻¹	(<i>p-r</i>) [sediments] mmol m ⁻² d ⁻¹
TN budget 94/95	-1.4 ± 3.5		---	---
TN budget 95/96	+0.2 ± 11.9			
TDN:TDP 94/95 dry	-5.0 ± 1.0	-9.2 ± 1.6		
TDN:TDP 94/95 annual	-4.8 ± 2.5	-8.4 ± 4.8	-101	-33
TDN:TDP 95/96 dry	-3.1 ± 0.5	-6.7 ± 1.1	-94	-31
TDN:TDP 95/96 annual	+1.2 ± 9.9	-0.6 ± 15.9	-47	-15
Eyre 1996 (this issue)	---	+3.9	+8	---

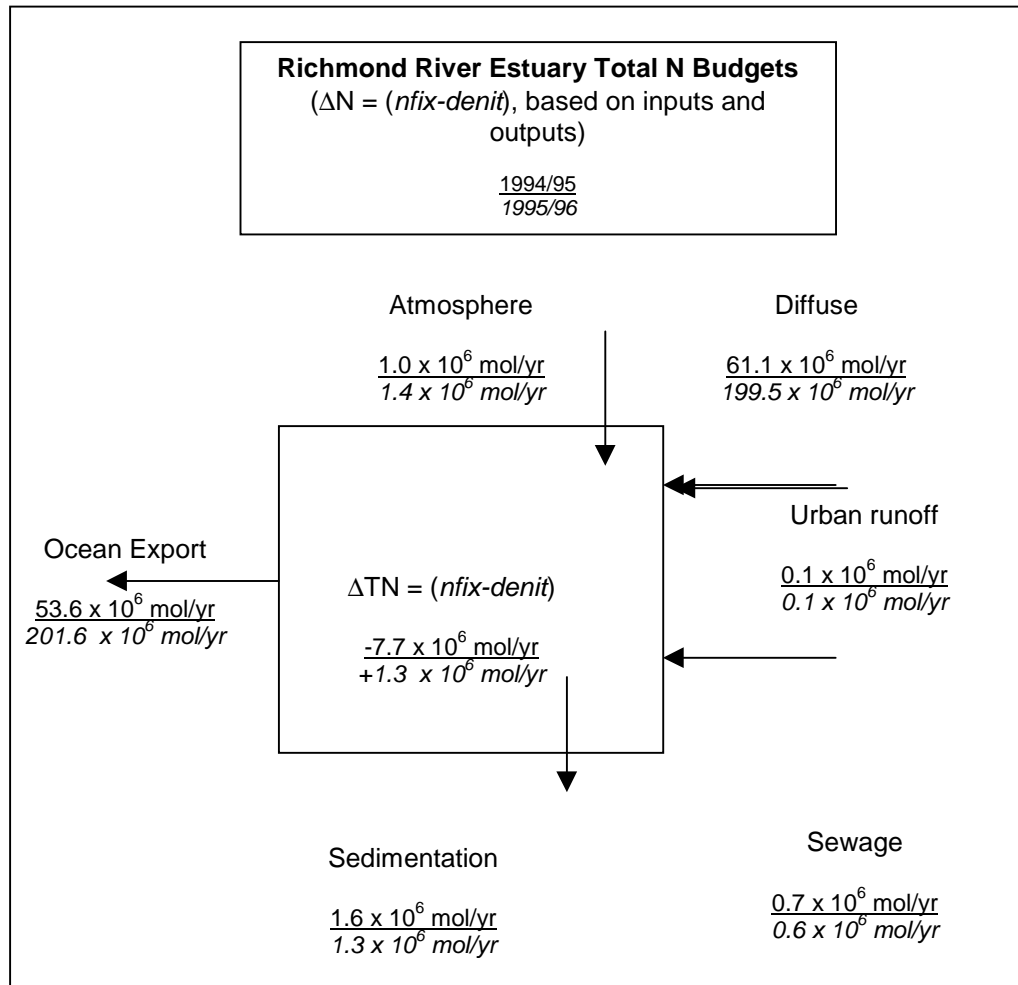

Figure IV.3 Total N budgets for two years, Richmond River estuary. [ΔTN is calculated as the difference between the summed inputs and summed outputs.]

TDP and TDN stoichiometry

Budgets for TDP and TDN are presented using both the sediment composition of Richmond sediments (323:3.2:1) and the Redfield ratio (106:16:1) for comparison (Figure IV.4 to IV.7). When (*nfix-denit*) is computed using stoichiometric relationships (approximately the LOICZ method) and annual TDP and TDN budgets, the errors render the results indistinguishable from zero for the same reasons as suggested for the TN budgets. If the dry seasons are considered separately, net denitrification computed for both years was significantly different from zero. During the dry seasons in the Richmond River estuary, flushing intervals are long relative to the biogeochemical processes occurring within the system. As such, the residuals of the TDP and TDN budgets are large relative to the errors associated with the quantification of the input and output terms. Another estimate of (*nfix-denit*) was made for the Richmond River estuary for 1996 (Eyre, Section 2.1.2), using the LOICZ methodology (Gordon *et al.* 1996), estimated net nitrogen fixation.

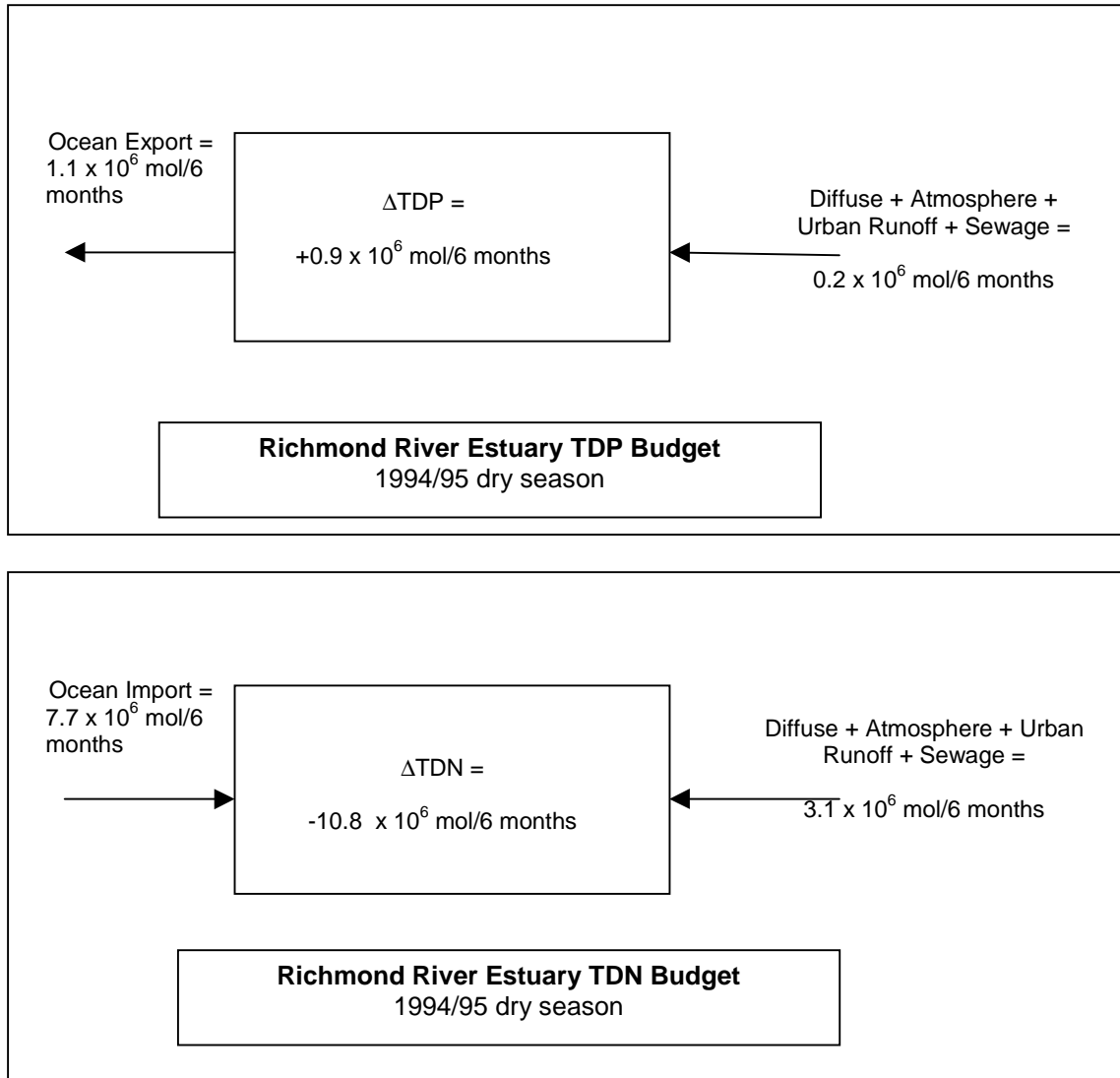

Figure IV.4 TDP and TDN budgets for the 1994/1995 dry season Richmond River estuary. [ΔTDP and ΔTDN are estimated by the difference between the summed inputs and oceanic output. The estimate of (*nfix-denit*) given in Table IV.1 is determined according to the LOICZ method ($[nfix-denit] = \Delta DIN_{obs} - \Delta DIN_{exp}$, where ΔDIN_{exp} is estimated either from the sediment particulate N:P ratio or from the Redfield N:P ratio)].

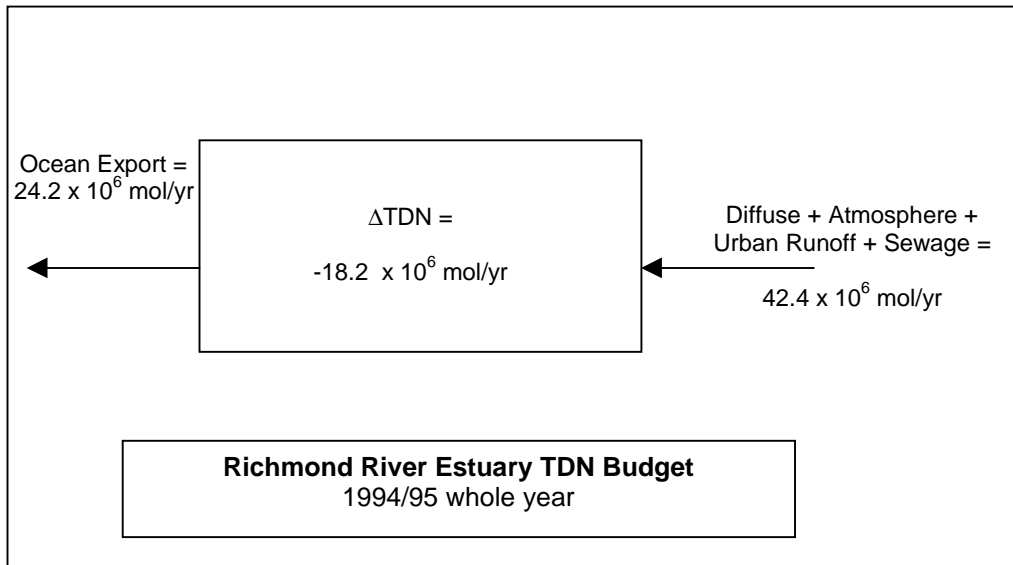
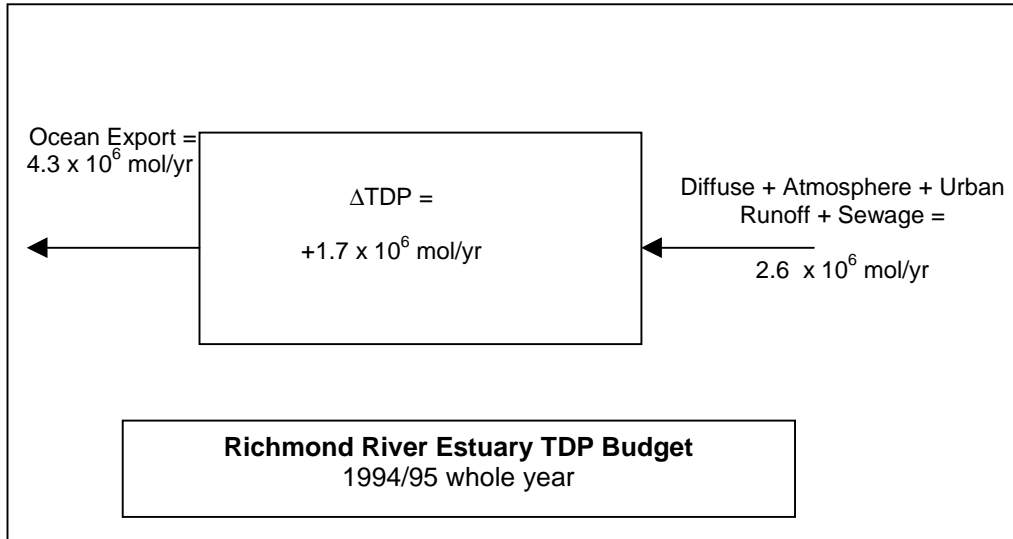

Figure IV.5 TDP and TDN budgets for the entire 1994/95 water year, Richmond River estuary. [Details as given in Figure IV.4.]

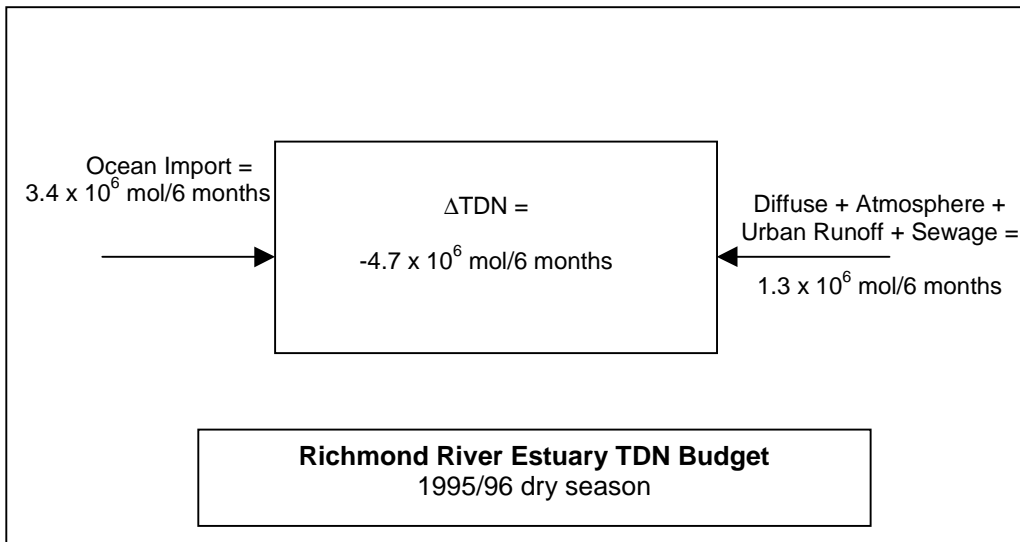
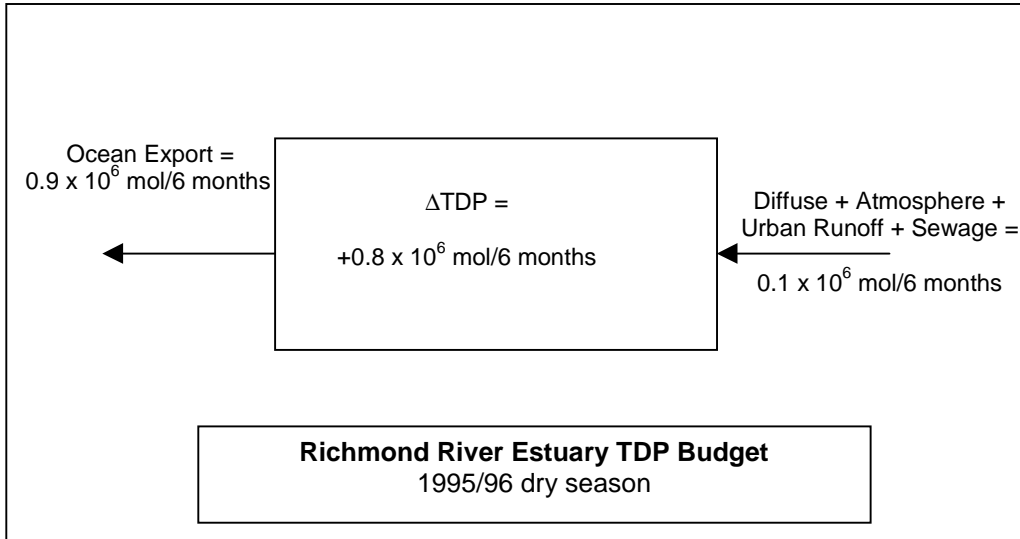

Figure IV.6 TDP and TDN budgets for the 1995/96 dry season, Richmond River estuary. [Details as given in Figure IV.4.]

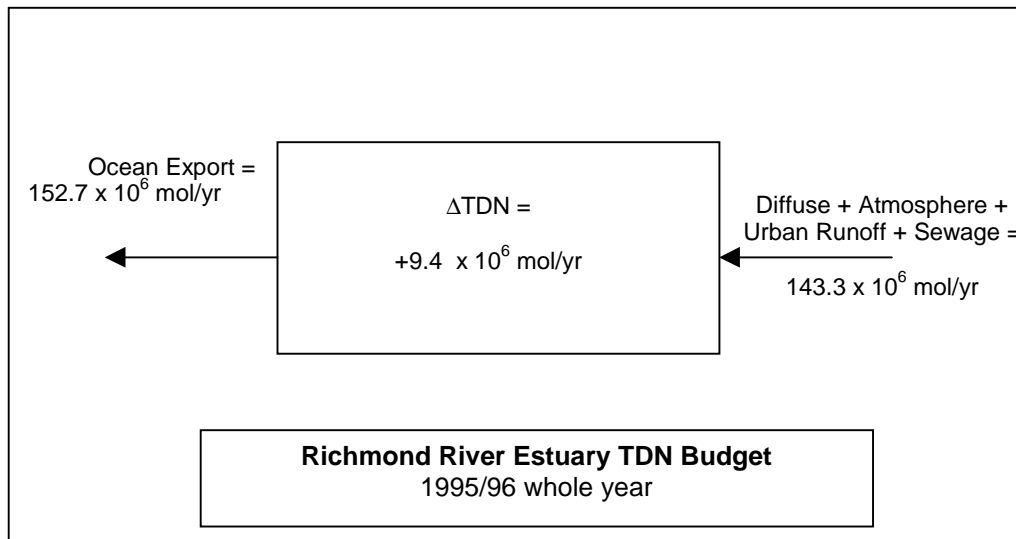
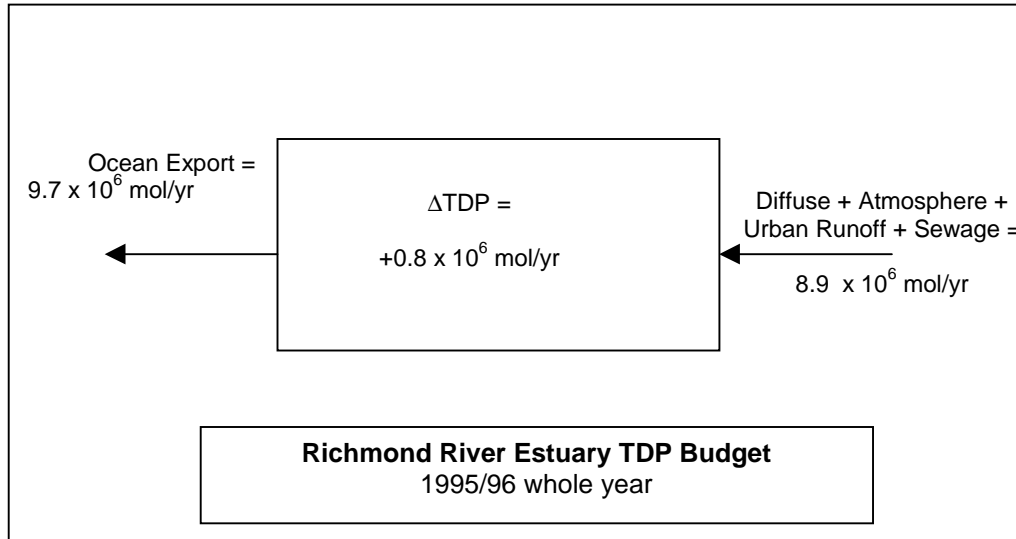

Figure IV.7 TDP and TDN budgets for the entire 1995/96 water year Richmond River estuary. [Details as given in Figure IV.4.]

Phosphorus-carbon stoichiometry

Scaling ΔTDP to the sediment C:P ratio (LOICZ methodology) gives an estimate of the net ecosystem metabolism ($p-r$) (Table IV-1). Here, the chosen sediment nutrient ratios make a large difference in the magnitude of ($p-r$). The Richmond River estuary appears to be respiring about 30 to 100 mmol m⁻² d⁻¹ organic carbon, depending on the chosen sediment nutrient ratios. These rates are larger than predicted by Eyre (Section 2.1.2), using the LOICZ budgeting approach, and opposite in sign.

APPENDIX IVB SWAN CANNING ESTUARY: SEASONAL NUTRIENT FLUXES USING A STEADY-STATE MASS BALANCE MODEL

D. Fredericks, D. Heggie and A. Longmore

Nutrient Mass Balance

Steady-state mass balances for estuaries have been considered in some detail by a number of authors (Liss and Spencer 1970, Boyle et al. 1974, Officer 1979, Smith and Atkinson 1983, Kaul and Froelich 1984, Smith and Veeh 1989) and despite a number of limitations have been applied in a wide variety of settings (Fisher *et al.* 1988, Zhang *et al.* 1997, Eyre and Twigg 1997, Smith and Atkinson 1983).

In these models the catchment flux of any species to the estuary is given by

$$F_c = QC_0$$

where F_c is the catchment flux, Q is the discharge and C_0 is the freshwater concentration of the species. The flux of this species past an isohaline surface isohaline surface (x) within the estuary is estimated from

$$F_x = Q(Ck^*)$$

where Ck^* is the apparent freshwater concentration at the isohaline - the y intercept of the tangent to concentration salinity curve as illustrated in Figure IV.8.

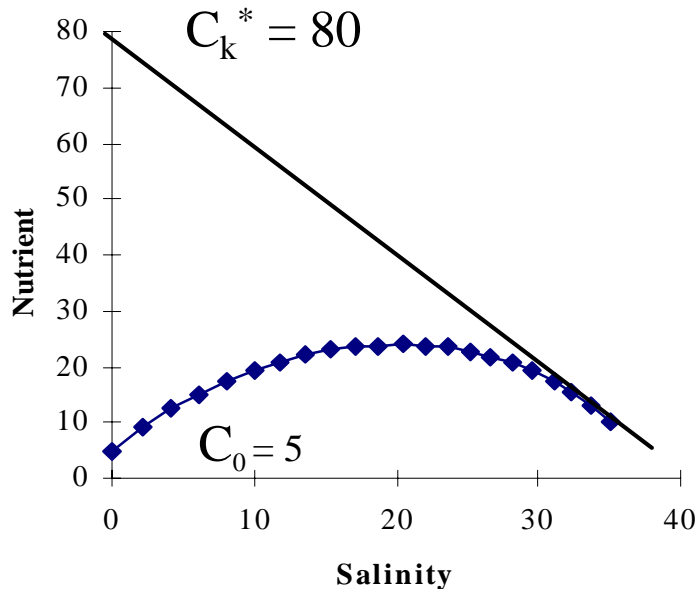

Figure IV.8 Example of nutrient parameter cross plot.

The flux of nutrient species from the catchment may be added to or reduced by biogeochemical processes operating in the estuary. The loss or gain of an element within the estuary can be determined from the difference between the flux from the river (QCk_0) and the flux across the marine isoconcentration surface.

$$L = QCk_0 - QCk^*$$

$$L = Q(Ck_0 - Ck^*)$$

Where Ck_0 is the steady state concentration of the component k in the river.

Thus the determination of a steady state mass balance using this model requires accurate definition salinity - property relationships within the estuary. Sampling is carried out on the basis of salinity gradients within an estuary rather than sampling at fixed stations.

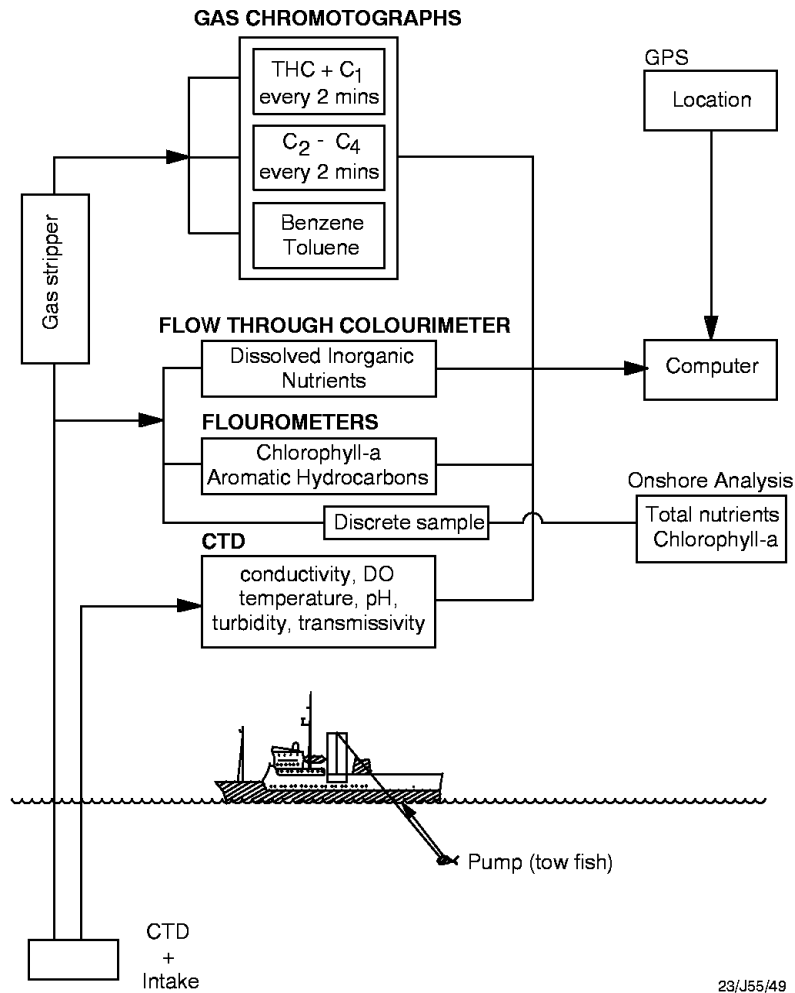
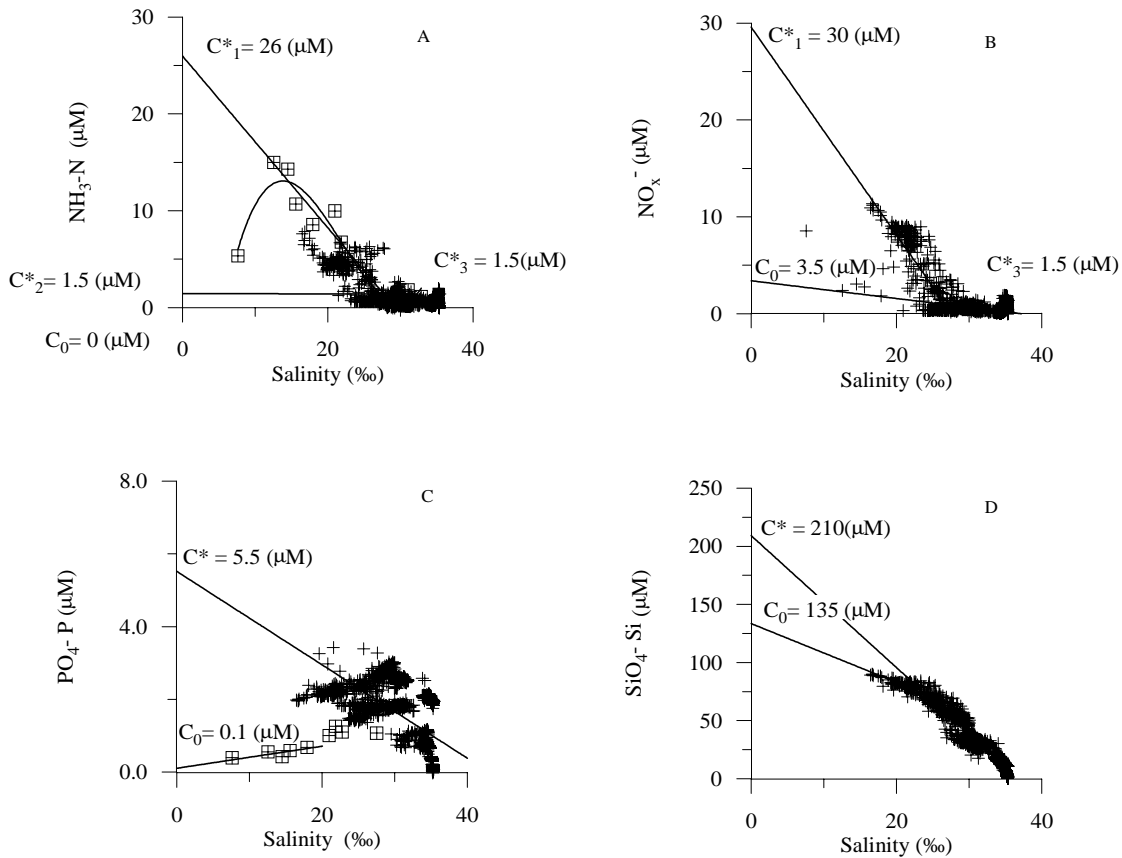

Figure IV.9 Flow diagram of the continuous sampling and analysis of seawater undertaken in this investigation.



Transect of Swan Canning Estuary, June 10 -13 1996

flux1_1.grf

Figure IV.10 Survey 1 - Cross plot of salinity and dissolved inorganic nutrients - low flows, Swan Canning estuary.

Most investigators have used discrete sampling to define salinity-property relationships, sampling at each 1‰ change in salinity (Eyre and Twigg 1997, Kaul and Froelich 1984). We have used a system of real time continuous sampling as this provides higher resolution, the ability to identify small point sources and to modify sampling design in response to observed variations in water parameters.

Continuous Geochemical Tracers (CGT)

The study utilised continuous measurements of water properties in two surveys undertaken by AGSO and MAFRI. Continuous data collected in our surveys included:

- Temperature, salinity, dissolved oxygen (DO) and turbidity using a Yeo-Kal CTD.
- Automated measurement of dissolved nitrite (NO₂-N), nitrate (NO₃-N), ammonia (NH₃-N), orthophosphate (PO₄-P) and silicate (SiO₄-Si) in surface waters by flow through colorimetric methods and chlorophyll *a* by flow through fluorometry.

Vertical profiles of the water column were undertaken using a CTD probe at a number of locations within the estuary and nutrient samples were collected at 1m from the surface and 1m from the bottom. Samples were also collected for TN, TP, alkalinity and total suspended solids.

A flow diagram of the continuous sampling and analysis of seawater undertaken in this investigation is shown in Figure IV.9.

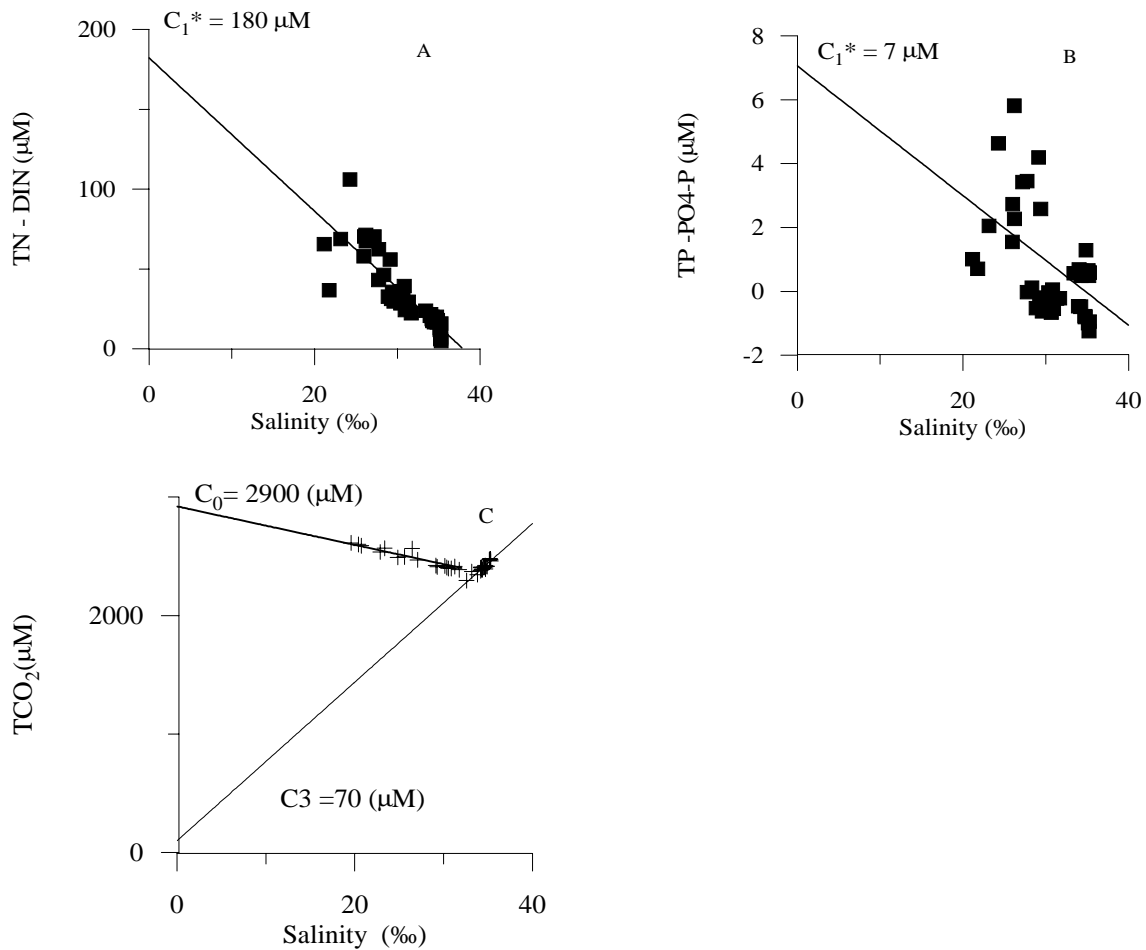

Figure IV.11 Survey 1 - Salinity parameter cross plot for early winter - low flows, Swan Canning estuary. (Concentration of N and P in Fremantle Harbour/Blackwall Reach were ignored in the surface layer model. This water enters the estuary as a bottom layer and was not part of the surface layer considered in this analysis. There was an unresolved discrepancy between NO_x measured by AGSO/MAFRI and bottle samples analysed by WRC.)

Winter - Low flow

Salinity/parameter cross plots for low flow conditions at the beginning of winter are shown in Figures IV.10 and IV.11. Nutrient fluxes estimated for the upper and lower estuary (surface layer) are shown in Table IV.2.

Table IV.2 Nutrient budget - low winter flows, Swan Canning estuary.

Upper Estuary CATCHMENT FLUX (F ₀)							
		TCO ₂	NH ₃ -N	NO _x -N	TN-DIN	PO ₄ -P	TP-PO ₄ -P
Q	10 ⁶ m ³ day	n/d	0.05	0.05	0.05	0.05	0.05
C ₀	μM	n/d	5	30	180	0.1	7
Flux	moles/day	n/d	250	1500	9000	5	350
Upper Estuary ⇒ Lower Estuary FLUX (F ₂₅)							
Q	10 ⁶ m ³ day	0.05	0.05	0.05	0.05	0.05	0.05
C*	μM	2900	26	30	180	2	7
Flux	moles/day	145 000	1300	1500	9000	100	350
Lower Estuary - Flux (F ₃₅)							
Q	10 ⁶ m ³ day	0.05	0.05	0.05	0.05	0.05	0.05
C*	μM	70	1.5	1.5	180	5.5	7
Flux	moles/day	3500	75	75	9000	275	350

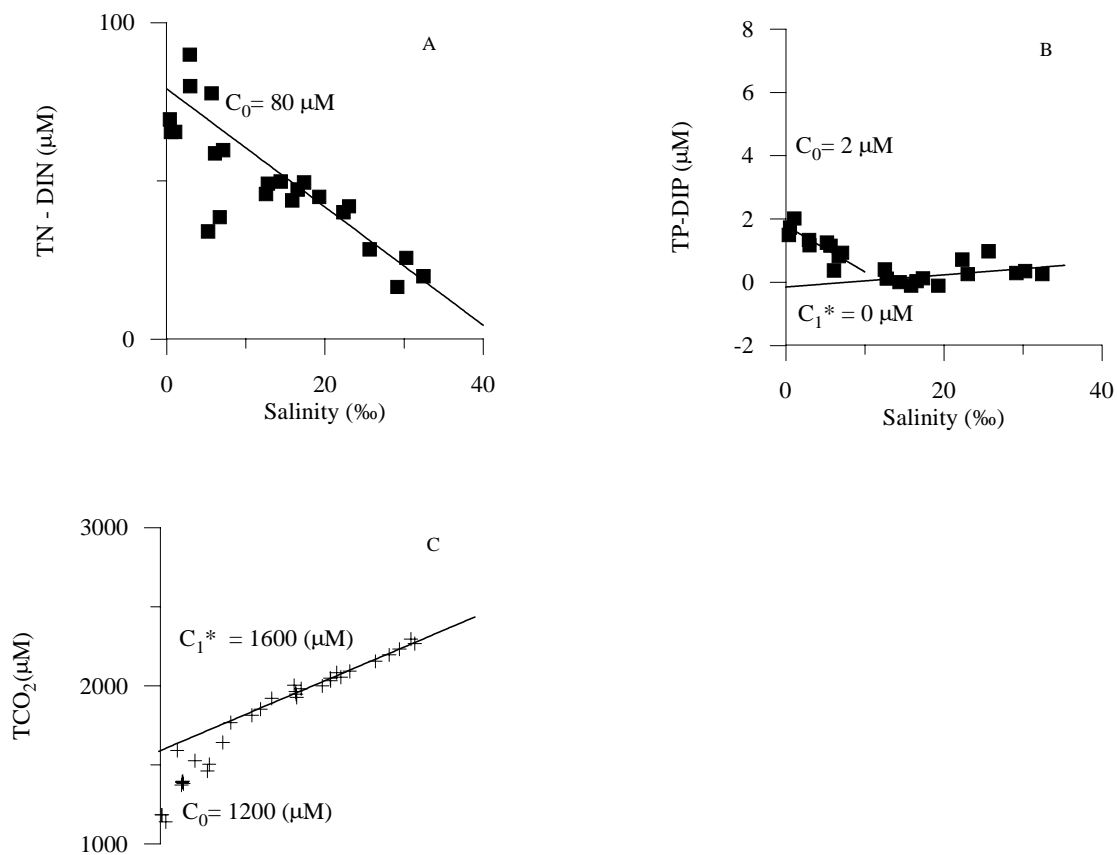
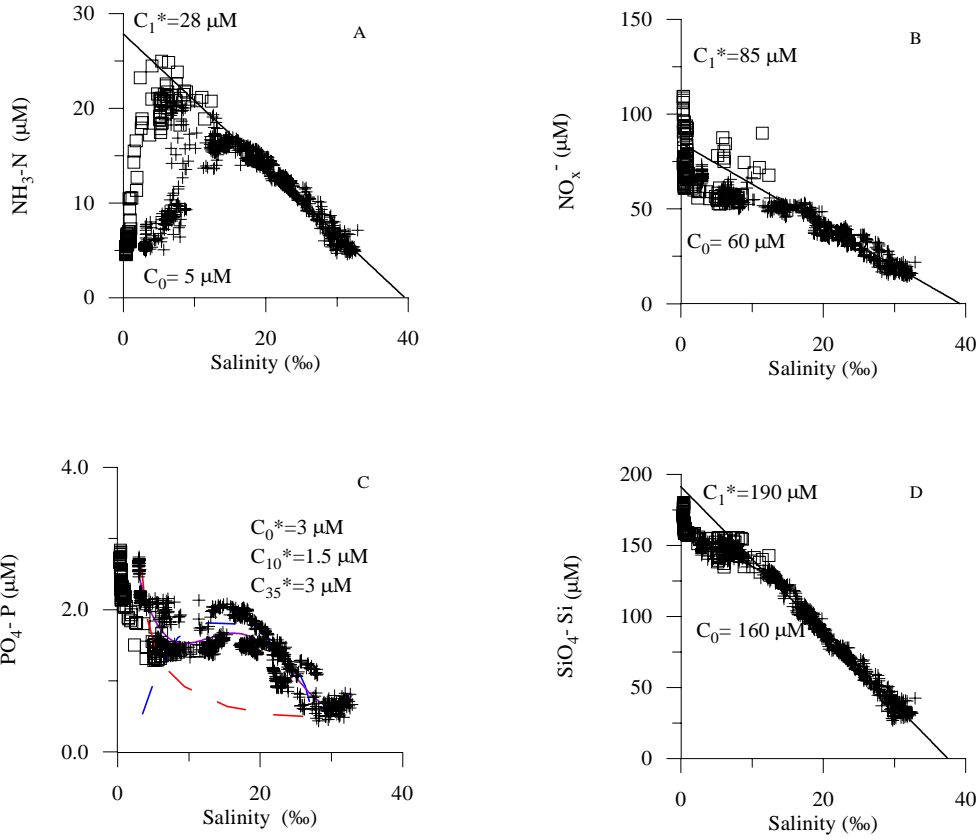

Figure IV.12 Salinity parameter cross plot - high winter flows, Swan Canning estuary.



Transect of Swan Canning Estuary, July 15 1996

flux3_1.grf

Figure IV.13 Salinity parameter cross plots - winter high flow, Swan Canning estuary. (+ = Swan Estuary, = Canning. Discharge data unavailable for the Canning so this estuary was not included. Discharge from the Canning River is likely to be a minor component of the water budget since the catchment is small and contains a relatively large reservoir.)

Table IV.3 Nutrient budget - high winter flows, Swan Canning estuary.

Catchment Flux (F ₀)								
		TCO ₂	NH ₃ -N	NO ₂ -N	NO _x -N	TN-DIN	PO ₄ -P	TP-DIP
Q	10 ⁶ m ³ day	15	15	15	15	15	15	15
C ₀	µM	1200	5	1	75	70	3	4
Flux	moles/day	18x10 ⁶	75 000	15 000	1 125 000	1 050 000	45 000	30 000
Flux to Marine Waters								
Q	10 ⁶ m ³ day	15	15	15	15	15	15	15
C*	µM	1600	30	3.5	81	80	3	0
Flux	moles/day	24 x 10 ⁶	450 000	52 500	1 215 000	1 200 000	45 000	0

Winter - High flow

This survey was undertaken only in the lower estuary as high river flows prevented access to the upper estuary/Swan River. Salinity/parameter cross plots for low flow conditions at the beginning of winter are shown in Figure IV.12 and IV.13. Nutrient fluxes estimated for the upper and lower estuary (surface layer) are shown in Table IV.3. This budget refers to the surface layer of the lower estuary only.

Historical Nutrient Data

The detailed surveys undertaken by AGSO represent only a part of the seasonal pattern of nutrient cycling within the estuary; specifically, low flows at the onset of the winter rains and high flows following major rainfall. To broaden the perspective on nutrient cycling we have analysed the water quality data collected by WRC in 1995/96. The seasonal data, combined with salinity/nutrient cross plots utilised in the previous section, were then used to infer the major processes that control nutrient concentrations and dynamics in the estuary for each season.

We identified three key periods based on the water quality data set and our detailed studies reported above:

1. Winter - high flows, high rates of nutrient input but short residence times, cold temperatures and low light which make conditions less favourable for significant nutrient uptake within the estuary;
2. Spring - a period when runoff from the catchment is still delivering nutrients to the estuary but the longer residence times, warmer temperature and greater light provide suitable condition for uptake of nutrients by phytoplankton.
3. Late Summer - low or zero flows result in the intrusion of marine waters, stratification of the estuary and a build up of nutrient concentration in bottom waters.

Discharge

The catchment discharge for each survey (Table IV.4) was estimated by averaging discharge from the Avon River over the freshwater replacement time for the estuary (Kaul and Froelich 1984), and assuming that the Avon River contributed about 80% of runoff.

Table IV.4 Estimate average flow for each date, Swan Canning estuary.

Date	Average Flow Rate (m ³ day ⁻¹)
High Flow - Winter 18 July 1995	13 x 10 ⁶
Moderate Flow - Spring 24 October 1995	1.7 x 10 ⁶
Low Flow - Summer 22 January 1996	-1.75 x 10 ⁶

There was no recorded runoff from the Avon River in April and May 1996. During this period of the hydrologic year, the estuary behaves as a salt wedge estuary and there is a

net flow of marine waters into the estuary. We have estimated the net volume of intruding marine water from the volume of the estuary and the observed change in average salinity. Examination of the salinity record for the Armstrong Station shows that marine waters started to intrude into the estuary in early August 1995 and we have used this date to estimate an average daily rate of marine water intrusion.

Apparent Concentrations

The apparent concentrations used to estimate each flux were determined by extrapolation of the nutrient/salinity relationships to predict apparent end-member concentrations. Where this proved difficult because of the nature of the data, we have estimated of end-member composition (mainly seawater) from other sources.

High Flow - 18 July 1995

Winter rains started relatively early in 1995, the first significant runoff being recorded in late May and the first flood peak in June. By July 18, discharge had increased to about $13 \times 10^6 \text{ m}^3 \text{ day}^{-1}$, salinity had dropped to an estuary-wide average of about 5‰, and water temperature to about 15°C.

Cross plots of water quality parameters against salinity were constructed from WRC data collected on 18-July-1995 (Figure IV.14). The WRC data are limited (for this purpose) but are consistent with the more detailed interpretation based on our survey undertaken in July 1996. The WRC data show that:

1. the NH_4^+ -N/salinity relationship must be “concave up” indicating a net input of NH_4^+ -N within the estuary;
2. there are high concentration of both nitrate and total N in catchment runoff; and
3. there is evidence of removal of DIN and Total P within the estuary.

Table IV.5 Estimated fluxes - winter 1995, Swan Canning estuary.
(The estuary is treated as a single box.)

	Catchment Flux	Internal Flux	Flux Out
	(moles/day)		
NH_4	26 000	143 000	169 000
$\text{NO}_x\text{-N}$	585 000	0	585 000
$\text{PO}_4\text{-P}$	29 900	-16 900	13 000
SiO_4	5 980 000	0	5 980 000
TN-DIN	1 170 000	0	1 170 000
TP - $\text{PO}_4\text{-P}$	44 200	0	44 200

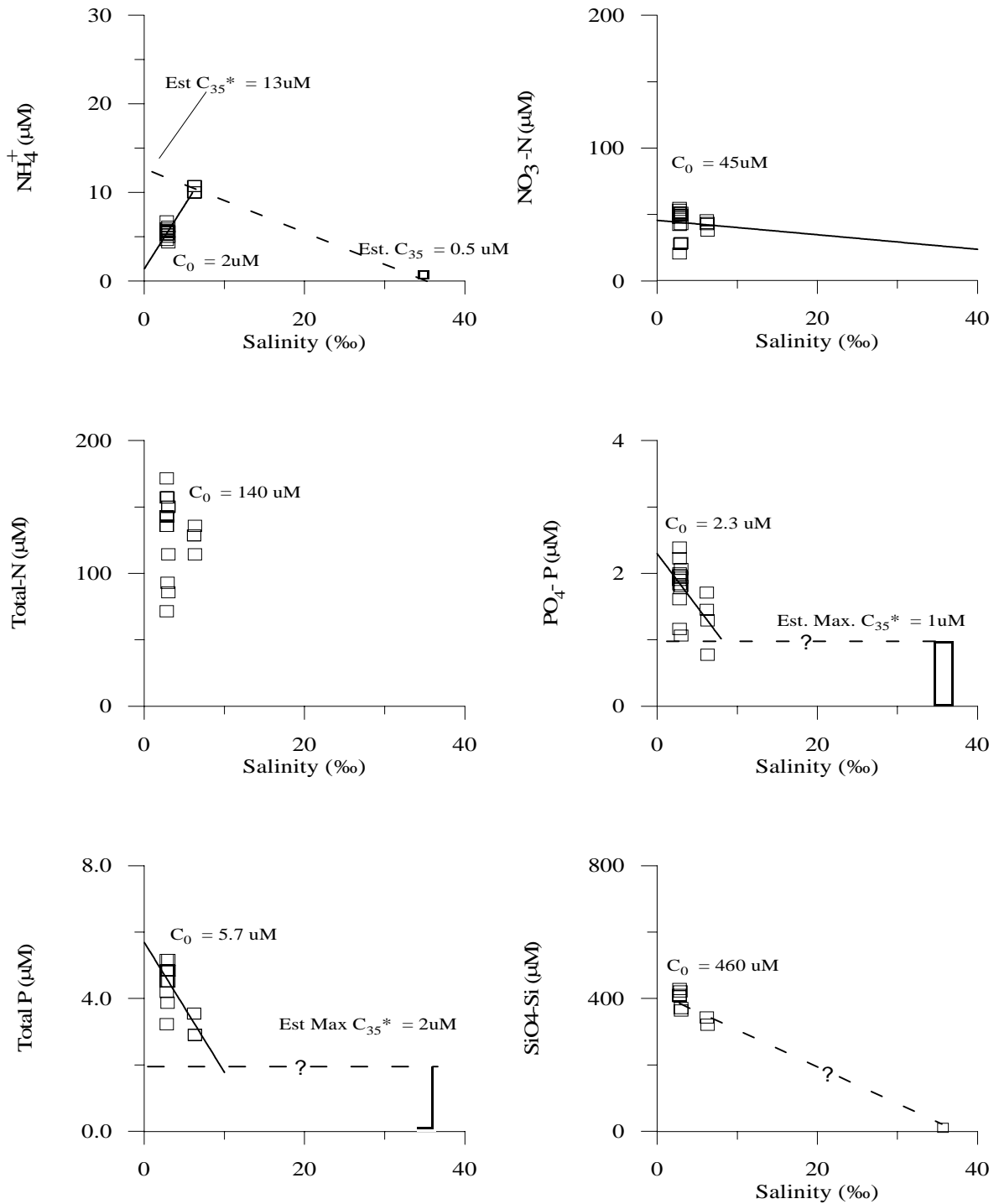

Swan Estuary - concentration of nutrients in surface waters plotted against salinity.
WRC monitoring 18-07-95

950718xp.grf

Figure IV.14 Winter - nutrient/salinity cross plots (18 July 1995), Swan Canning estuary.

Spring - 24 October 1995

By October, discharge from the catchment had dropped to about $1.4 \times 10^6 \text{ m}^3 \text{ day}^{-1}$, or about one tenth of that in July. In addition, water temperatures had increased to an estuary-wide average of about 18°C and surface salinities were about 10‰.

Cross-plots of nutrient concentration versus salinity for 24 October 1995 are shown in Figure IV.15. Again, the data are fragmentary as they were only collected over a salinity range of about 0 -20‰, and do not include the marine end-member. We have included estimates of marine concentration of each nutrient to facilitate interpretation.

It can be seen from Figure IV.15 that

1. the concentration of $\text{NH}_4^+\text{-N}$ shows a complex relationship with salinity. The relationship is apparently “concave up” at low salinities indicating internal input of $\text{NH}_4^+\text{-N}$ in the upper estuary. However, the concentration of $\text{NH}_4^+\text{-N}$ in the lower estuary is significantly less than expected from simple mixing with a marine end-member and this suggests removal of $\text{NH}_4^+\text{-N}$ in the lower estuary (Perth and Melville Waters);
2. the relationship between $\text{NO}_x\text{-N}$ and salinity also indicates N removal at higher salinities, but there is no evidence for any internal input in the upper estuary;
3. total nutrient data suggest conservative behaviour of TN;
4. P data are limited but suggest internal input of both DIP and TP at low salinities and removal at higher salinities (lower estuary); and
5. silicate data are limited but there is some evidence of removal.

Table IV.6 Estimated fluxes – spring 1995, Swan Canning estuary.

	Catchment Flux	Internal Input (Upper)	Internal Removal (Lower)	Net Flux
	moles/day			
NH_4	8500	8500	-15 980	1020
$\text{NO}_x\text{-N}$	20 400	0	-17 680	2720
$\text{PO}_4\text{-P}$	1190	2210	-2890	510
SiO_4	765 000	765 000		1 530 000
TN-DIN	1 170 000	0		
TP - $\text{PO}_4\text{-P}$	13 000	0		

Summer - 22 January 1996

By January, discharge from the catchment had dropped to near zero and there was a net inflow of marine water into the estuary. Water temperatures had increased to an estuary-wide average of about 27°C and salinities to an average of about 28‰.

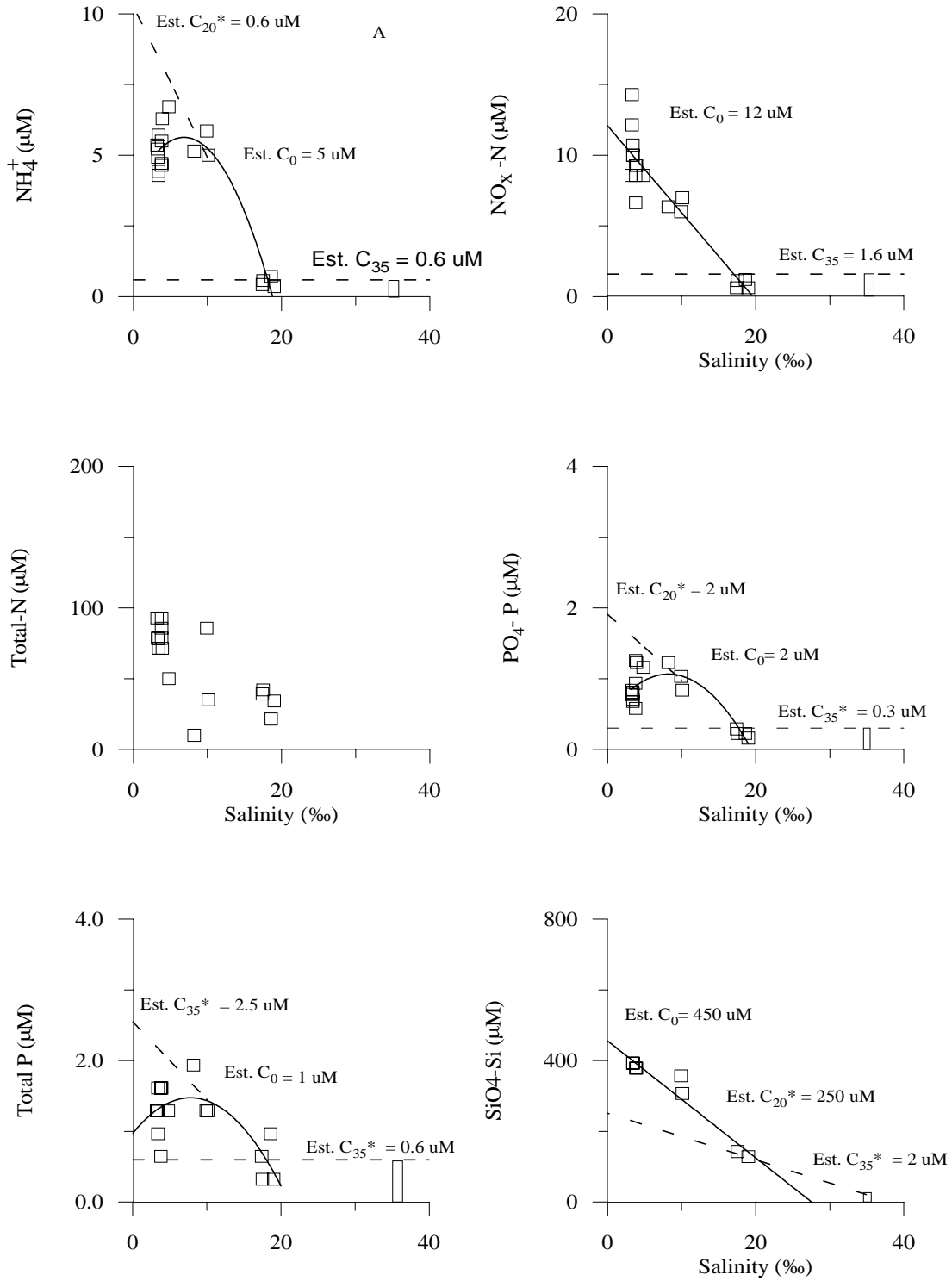

Swan Estuary - concentration of nutrients plotted against salinity. WRC monitoring 24-10-95

951024xp.grf

Figure IV.15 Spring - nutrient/salinity cross plots, Swan Canning estuary.

Cross plots of water quality parameters against salinity for 22 January 1996 are shown in Figure IV.16. Again, the data are fragmentary and were only collected over a salinity range of about 20 -35‰, which does not include the freshwater end-member.

It can be seen from Figure IV.16 that

1. the concentration of N species in the estuary is low;
2. the concentrations of both NH_4^+ and NO_x show a mid-estuary maximum indicative of internal input, and
3. DON is the dominant N species and behaves conservatively.

The silicate data from this survey was uninterpretable. However, other surveys undertaken during summer showed a slightly “concave up” mixing curve between seawater with a low silicate concentration mixing with high silicate freshwater indicative of a net internal input within the estuary.

We cannot fully interpret these data without measurements of salinity and nutrient concentrations in the upper reaches of the estuary between Success Hill and Ellen Brook (salinities less 20‰). Extrapolation of the data suggest that there is a net removal of nutrients in the area but this needs confirmation from additional sampling.

Estimated fluxes are presented in Table IV.7. External nutrient fluxes during summer are small in comparison with other seasons and we suggest that any phytoplankton blooms occurring in summer must derive the bulk of their nutrients from internal recycling.

Table IV.7 Estimated fluxes – summer, Swan Canning estuary.

	Flux towards catchment	Net Removal Upper Est.	Internal Flux Lower Est.	Flux from marine water into estuary
	moles/d			
$\text{NH}_4\text{-N}$	9000	-27 000	35 100	900
$\text{NO}_x\text{-N}$	900	-3600	3600	900
$\text{PO}_4\text{-P}$	1800	-5400	6300	900
SiO_4	0	0	-18 000	18 000
TN-DIN	36 000	0	0	36 000
TP - $\text{PO}_4\text{-P}$	3600	-3600	6300	900

Uncertainties

Uncertainties in the flux estimates are difficult to determine as many of the interpretations have been made by extrapolation from typical marine concentrations. Uncertainties in estimates of apparent concentrations probably approach 50% in some cases. While this uncertainty may appear large it should be remembered that many of the net fluxes under investigation differ by an order of magnitude or more. In addition, the shape of the nutrient salinity relationship provides valuable qualitative information on the net balance of nutrient uptake and recycling within the estuary.

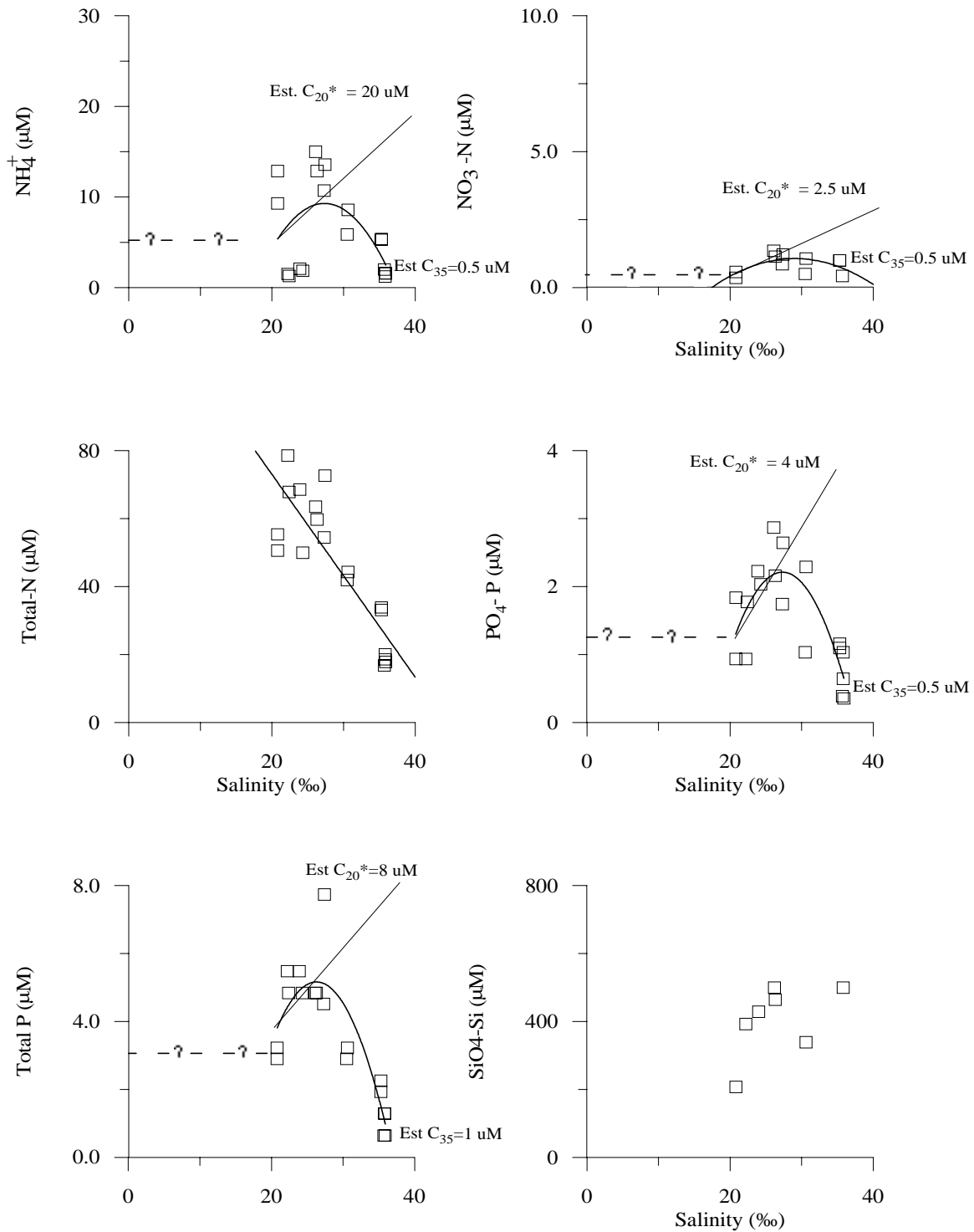

Swan Estuary - concentration of nutrients plotted against salinity.WRC monitoring 20-2-96

960220xp.grf

Figure IV.16 Summer - nutrient/salinity cross plots, Swan Canning estuary.

REFERENCES

- Boyle, E., Collier, R., Dengler, A.T., Edmond, J.M., Ng, A.C. and Stallard, R.F. (1974) On the chemical mass-balance in estuaries. *Geochimica et Cosmochimica Acta*. **38** (11):1719-1728.
- Eyre, B. and Twigg, C. (1997) Nutrient behaviour during post-flood recovery of the Richmond River Estuary Northern NSW, Australia. *Estuarine, Coastal and Shelf Science* **44**:311-326.
- Fisher, T.R., Harding, L.W., Stanley, D.W. and Ward, L.G. (1988) Phytoplankton, nutrients, and turbidity in the Chesapeake, Delaware, and Hudson Estuaries. *Estuarine, Coastal and Shelf Science* **27**:61-93.
- Gordon, D.C. Jr., Boudreau, P.R., Mann, K.H., Ong, J.-E., Silvert, W.L., Smith, S.V. Wattayakom, G., Wulff, F. and Yanagi, T. 1996 LOICZ Biogeochemical Modelling Guidelines. *LOICZ/R&S/ 95-5*, LOICZ, Texel, The Netherlands.
- Hossain, S. 1998 Hydrology and suspended sediment transport in the Richmond River catchment and estuary NSW Australia. *PhD thesis*, Southern Cross University, New South Wales.
- Kaul, L.W. and Froelich, P.N.R. (1984) Modeling estuarine nutrient geochemistry in a simple system. *Geochimica et Cosmochimica Acta* **48** (7):1417-1433.
- Liss, P.S. and Spencer, C.P. (1970) Abiological Processes in the removal of silicate from sea water. *Geochimica et Cosmochimica Acta* **34**:1073-1088.
- Officer, C.B. (1979) Discussion of the behaviour of nonconservative dissolved constituents in estuaries. *Estuarine and Coastal Marine Science* **9** (1):91-94.
- Smith, S.V. and Atkinson, M.J. (1983) Mass balance of carbon and phosphorus in Shark Bay, Western Australia. *Limnology and Oceanography* **28** (4):625-639.
- Smith, S.V. and Veeh, H.H. (1989) Mass balance of biogeochemically active materials (C,N,P) in a hypersaline gulf. *Estuarine, Coastal and Shelf Science* **29** (3):195-215.
- Zhang, J., Yu, Z.G., Liu, S.M., Xu, H. and Liu, M.G. (1997) Dynamics of nutrient elements in three estuaries of North China: The Luanhe, Shuangtaizhe, and Yalujiang. *Estuaries* **20** (1):110-123.

1. Welcome

Participants were welcomed to CSIRO Land and Water by the Division Chief, Dr Graham Harris, who highlighted both the Australian scientific initiatives being taken in the coastal arena, especially by CSIRO, and the continuing efforts of CSIRO Land and Water to further its international activities and profile.

Participants were introduced and working documents were distributed.

2. Introduction and Background

2.1 LOICZ Core Project

An outline of LOICZ goals and approaches was presented by Dr Chris Crossland, who stressed the importance of the Workshop outcomes (see Terms of Reference, Appendix VII) to the continuing development of understanding of global change in the coastal zone within the International Geosphere-Biosphere Programme (IGBP). Key elements of the Project place emphasis on determining horizontal material fluxes at localities and sites, scaling site information to the regional and global dimensions by typological (coastal classification) methods, and linking flux information to the human dimension. The pivotal nature of derived biogeochemical budgets within LOICZ was highlighted, and the links to other elements of the Project (river catchments, typology, human dimension) were briefly described.

2.2 Overview of Workshop

The Workshop leader, Prof Steve Smith, described the purpose of the Workshop and the approach and progress of LOICZ in developing biogeochemical budgets. The LOICZ protocol for biogeochemical budgets in estuaries is one approach, among a number that could be used. However, this provides a common approach that allows comparisons between global sites, particularly for regions with limited data describing the relevant estuarine and coastal parameters. The development of a global statement by end 2002, depends on LOICZ accessing and using available data for the budgets and, by use of a series of typologies, to extrapolate regional sites information to a picture of the world's coastal zone. In addition, several relatively data-rich sites and regions should be explored in detail to extend the overall first-order assessment to areas of second and third order budgets which allow further assessment of forcing functions and system responses.

Realising a global assessment by LOICZ will require more than 100 site budgets. In addition to the budget developments, the work is delivering new tools for assessment of system function, such as relationships between salt and tidal exchange times.

The program for the Workshop and for report preparation was outlined for guidance of participants.

2.3 Systems Comparisons - Australian Estuaries and Lakes

The status and special nature of the Australian estuaries and embayments was outlined by Dr Graham Harris, noting the level of scientific understanding of the pressures and

system processes. A range of features and issues were considered including their “marine” nature, their limited freshwater inputs, the often relatively long water residency times, and their sensitivity to land use and hydrology. Generally they are shallow and have strong macrophyte habitats, and they do not remain in “a steady state” for long due to seasonal variations in rainfall. Consideration was given to the implications of these factors on the types of models required to represent system processes.

The plenary presentation is contained in Appendix I.

2.4 Australian Coastal Zone Factoids

An overview of the physical and geographical diversity of Australasian estuaries was provided by Dr Bradley Opdyke, with contributions from Dr Brad Eyre about the classification systems being developed to describe the diversity of systems (see Appendix II). It is apparent that for many localities there is a large amount of data available, on the web and in other public domain sites, which is relevant to biogeochemical budget development. These data need to be compiled and integrated into systems models for use in management and expanding our understanding of the region’s coastal dynamics.

3. Presentation of Australasian Biogeochemical Budgets

The budgets contributed to the Workshop covered a range of regional areas and climatic conditions.

The contributed budgets for the systems were briefly considered by participants, including an overview of the system settings, data availability, approaches being taken to build the biogeochemical budgets, and the status and problems in development of estimates. Several existing budgets were reviewed in light of new information. Systems presentations included:

Modelled with LOICZ methods

Swan River, Western Australia	Dr Malcolm Robb & Linda Kalnejais
Cockburn Sound, Western Australia	Dr Tony Chiffings
Wilson’s Inlet, Western Australia*	Dr Malcolm Robb
Hardy Inlet, Western Australia	Dr Malcolm Robb
Port Phillip Bay, Victoria	Drs John Parslow & Graham Skyring
Gippsland Lakes, Victoria	Drs Phillip Ford & Ian Webster
Derwent River, Tasmania	Dr John Parslow
Lake Illawarra, New South Wales	Dr John Morrison & Kathie Miller
Hawkesbury-Nepean system, New South Wales	Gary Bickford
Queensland and northern NSW systems (11)	Dr Brad Eyre
Central Great Barrier Reef, Queensland*	Dr Miles Furnas
Fly River, Papua New Guinea	Dr Bradley Opdyke
Hauraki Gulf, New Zealand	Dr John Zeldis

* currently listed at the LOICZ biogeochemical budget models website (www.nioz.nl/loicz/); additional data are being incorporated

Modelled with non-LOICZ methods (see Appendix IV)

Richmond estuary, New South Wales
Swan Canning system, Western Australia

Lester McKee and Dr Brad Eyre
Dr David Fredericks

Throughout the presentations, there were discussions on a range of issues, both generic and specifically related to the individual systems, including:

- how to assess estuaries regarding the freshwater inputs and evaporation processes,
- the implications for evaluation of data by aggregation to annual averages and/or by seasonal sets,
- dealing with stratified systems, and
- the use of multi-box model approaches.

Water residency and retention times, and the impact of seasonal and episodic events on budget modelling were considered, especially in relation to the “big picture” classification of the region, previously presented in the “Factoid” session.

4. Budgets Development

Break-out groups worked interactively on the development of these and additional site budgets, supplemented with methodological and site/issues-based tutorials and discussions. Estimates for sites and evolution of assessment approaches were made, often incorporating more detailed spatial and temporal boxes and data in the models. Budget refinements were made in light of outcomes from individual and group discussions of issues emerging from additional plenary sessions.

5. Additional Plenary Sessions and Discussions

Two additional plenary sessions were developed from early discussion about various site budgets:

- **Sensitivity and Analysis of Models**
Drs John Parslow and Ian Webster delivered a consideration of the errors and assessment of sensitivity for the biogeochemical budgets derived through the LOICZ approach, and the implications of episodic river flows on the methodology. Appendix III contains the derived discussion paper addressing these issues.
- Preliminary latitudinal comparisons and patterns in the nutrient budget data and systems assessment

DR BRAD EYRE PROVIDED AN OUTLINE OF INITIAL LATITUDINAL PATTERNS EMERGING FROM THE WORKSHOP RESULTS. THESE OBSERVATIONS ARE CONTAINED IN PART IN THE WORKSHOP OVERVIEW (SECTION 1) AND APPENDIX II, AND A WIDER CONSIDERATION IS BEING PREPARED FOR PUBLICATION IN GLOBAL LITERATURE.

6. Outcomes and Wrap-up

Completed budgets for all systems were developed to a final stage of completion; some required additions to text descriptions and a check on data sources before contribution. Participants provided copies of their complete estimates for inclusion in the Workshop Report and for lodgement on the LOICZ website.

A number of additional sites were identified for which data is available and which may potentially yield budgets. Participants committed to making contact with other researchers for data and either to carry out or to encourage others to make further site evaluations for contribution to LOICZ. It became apparent through the Workshop that there are a number of localities in Australia for which there are relevant time-series data (more than a decade), often extending across management responses to nutrient enrichment input to the systems. For example, in the Hawksbury-Nepean system sewage treatment plants have been installed or modified to higher treatment technology. Also, in the Swan River system land use and channelisation management has been put in place. These areas could provide a valuable assessment of nutrient load impacts and remediation effects on the estuarine processes, fitting the LOICZ objective of gaining an understanding of links between the human dimension and processes influencing biogeochemical cycles.

The timetable for delivery of final budgets and publication of the Workshop Report was established: all contributions for the Report to be provided by 30 November 1998 with additional budgets to be contributed by 15 November 1998. The latter to be included in the Report and in a CD ROM containing the full regional information from this and a subsequent workshop in Mexico.

The participants joined with LOICZ in expressing thanks to the local organiser, Dr Bradley Opdyke, and Dr Graham Harris and staff of CSIRO Land and Water for support and for hosting the Workshop. The financial support for the Workshop by CSIRO Land and Water was gratefully acknowledged by LOICZ.

APPENDIX VI

Workshop Participants and Contributors

Gary Bickford

Sydney Water, Level 17
PO Box 453,
Sydney South, NSW 2000
AUSTRALIA
Telephone 61 2 9350 5382
Fax 61 2 9350 5929
Email gary.bickford@sydneywater.com.au

Gregg Brunskill¹

Australian Institute of Marine Science
PMB No.3, MSO
Townsville, Qld 4810
AUSTRALIA
Telephone 61 7 4753 4111
Fax 61 7 4772 5852
Email G_Brunskill@aims.gov.au

Tony Chiffings

Australian Water Technologies
PO Box 73
West Ryde, NSW 2114
AUSTRALIA
Telephone 61 2 9334 0711
Fax 61 2 9334 0792
Email tony_chiffings@awtensight.nsw.gov.au

Chris Crossland

LOICZ International Project Office
Netherlands Institute for Sea Research
PO Box 59, 1790 AB
Den Burg, Texel
THE NETHERLANDS
Telephone 31-222-369404
Fax 31-222-369430
Email loicz@nioz.nl

Peter Davies¹

Centre for Coastal Management
Southern Cross University
PO Box 157
Lismore, NSW 2480
AUSTRALIA

Vilma Dupra¹

Department of Oceanography
University of Hawaii
Honolulu, Hawaii 96822
USA
Telephone 1 808 956 2354
Fax 1 808 956 7112
Email vdupra@soest.hawaii.edu

Bradley Eyre

Centre for Coastal Management
Southern Cross University
PO Box 157
Lismore, NSW 2480
AUSTRALIA
Telephone 61 2 6620 3773
Fax 61 2 6621 2669
Email beyre@pophost.scu.edu.au

Phillip Ford

CSIRO Land and Water
GPO Box 1666
Canberra, ACT 2601
AUSTRALIA
Telephone 61 2 6246 5559
Fax 61 2 6246 5560
Email Phillip.Ford@cbr.clw.csiro.au

David Fredericks

Australian Geological Survey Organisation
Canberra, ACT 2601
AUSTRALIA
Telephone 61 2 6249 9434
Fax 61 2 6249 9589
Email dfrederi@agso.gov.au

Miles Furnas

Australian Institute of Marine Science
PMB No.3, MSO
Townsville, Qld 4810
AUSTRALIA
Telephone 61 7 4753 4323
Fax 61 7 4772 5852
Email mfurnas@aims.gov.au

Graham Harris

CSIRO Land and Water
GPO Box 1666
Canberra, ACT 2601
AUSTRALIA
Telephone 61 2 6246 5620
Fax 61 2 62465564
Email Graham.Harris@clw.csiro.au

David Heggie

Australian Geological Survey Organisation
Canberra, ACT 2601
AUSTRALIA
Telephone 61 2 6249 9589
Fax 61 2 6249 9980
Email dheggie@agso.gov.au

Linda Kalnejais

Water and Rivers Commission WA
Level 2 Hyatt Building
3 Plain Street
East Perth, WA 6001
AUSTRALIA
Telephone 61 8 9278 0525
Fax 61 8 9278 0586
Email linda.kalnejais@wrc.wa.gov.au

A. Longmore¹

Marine and Freshwater Resources Institute,
PO Box 114
Queenscliff, Vic.3225
AUSTRALIA

Lester McKee

Centre for Coastal Management
Southern Cross University
PO Box 157
Lismore, NSW 2480
AUSTRALIA
Telephone 61 2 6620 3493
Fax 61 2 6621 2669
Email lmckee@scu.edu.au

Kathryn McMahon¹

Water and Rivers Commission WA
Level 2 Hyatt Building
3 Plain Street
East Perth, WA 6001
AUSTRALIA

Cathee Miller

Environment Research Institute
University of Wollongong
Wollongong, NSW 2522
AUSTRALIA
Telephone 61 2 4285 4495
Fax 61 2 9330 6035
Email cmiller@spider.connectivity.net.au

John Morrison

Environment Research Institute
University of Wollongong
Wollongong, NSW 2522
AUSTRALIA
Telephone 61 2 4221 4134
Fax 61 2 4221 4665
Email john_morrison@uow.edu.au

Bradley Opdyke

Department of Geology
Australian National University
Canberra, ACT 0200
AUSTRALIA
Telephone 61 2 6249 4205
Fax 61 2 6249 5544
Email bno@geology.anu.edu.au

John Parslow

CSIRO Marine Research
GPO Box 1538
Hobart, Tas. 7001
AUSTRALIA
Telephone 61 3 6232 5202
Fax 61 3 6232 5000
Email John.Parslow@marine.csiro.au

Peter Pepperell¹

Centre for Coastal Management
Southern Cross University
P.O. Box 157
Lismore, NSW 2480
AUSTRALIA

Malcolm Robb

Water and Rivers Commission WA
Level 2 Hyatt Building
3 Plain Street
East Perth, WA 6001
AUSTRALIA
Telephone 61 8 9278 0526
Fax 81 8 9278 0586
Email malcolm.robb@wrc.wa.gov.au

Graham Skyring

Skyring Environment Enterprises
40 Atherton Street
Downer, ACT 2602
AUSTRALIA
Telephone 61 2 6241 1036
Fax 61 2 6241 9662
Email see@ozemail.com.au

Stephen V. Smith

Department of Oceanography
University of Hawaii
Honolulu, Hawaii 96822
USA
Telephone 1 808 956 8693
Fax 1 808 956 7112
Email svsmith@soest.hawaii.edu

Atsushi Suzuki¹

Australian Institute of Marine Science
PMB No.3, MSO,
Townsville, Qld 4810
AUSTRALIA
Telephone 61 7 4753 4111
Fax 61 7 4772 5852
Email asuzuki@pearl.aims.gov.au

Robert Wasson

Department of Geogaphy
Australian National University
Canberra, ACT 0200
AUSTRALIA
Telephone 61 2 6249 2475
Fax 61 2 6249 3770
Email robert.wasson@anu.edu.au

Ian Webster

CSIRO Land and Water
GPO Box 1666
Canberra, ACT 2601
AUSTRALIA
Telephone 61 2 6246 5581
Fax 61 2 6246 5560
Email Ian.Webster@cbr.clw.csiro.au

John Zeldis

10 Kyle Street
Riccarton, Christchurch
NEW ZEALAND
Telephone 64 6 3348 8987
Email j.zeldis@niwa.cri.nz

¹Did not attend workshop but contributed to budget preparation.

APPENDIX VII Workshop Agenda

LOICZ Workshop on Australasian Estuaries CSIRO Land & Water, Canberra, Australia 12-14 October, 1998

Agenda

Monday, October 12th

- 0830 Visitors meet in University House Lobby
- 0900 Welcome from Graham Harris, CSIRO in Pye Bldg, Seminar Room
- 0910 Chris Crossland, Comments from the LOICZ IPO
- 0920 Steve Smith, Short overview of workshop
- 0935 Graham Harris, Overview of system comparisons
- 1005 Brad Opdyke, Factoids about Australasian coastal zone
- 1100 John Morrison and Cathy Miller, Lake Illawarra, NSW
- 1140 Malcolm Robb and Linda Kalnejais, Wilson Inlet, WA
- 1220 John Parslow, Graham Skyring, Port Phillip Bay, Victoria
- 1300 LUNCH (on site)
- 1400 Ian Webster and Phillip Ford, Gippsland Lakes, Victoria
- 1440 Tony Chiffings, Cockburn Sound, WA
- 1600 Bradley Eyre and Lester McKee, Northern NSW estuaries
- 1700 Discussion

Tuesday, October 13th

- 0900 CSIRO Meeting Room, Comments from Steve Smith
- 0910 Dave Fredericks and Dave Heggie, Swan River, WA
- 0950 Bradley Opdyke, Fly River, Papua New Guinea
- 1100 John Zeldis, Hauraki Gulf, New Zealand
- 1140 Miles Furnas, GBR Lagoon, Queensland
- 1220 Plenary discussion: Where from here?
- 1300 LUNCH (on site)
- 1400 Breakout discussion and writing groups
- 1530 Continue discussion and writing groups
- 1700 Plenary discussion

Wednesday, October 14th

- 0900 CSIRO Meeting Room, Comments from Steve Smith
- 0910 Continue discussion, writing groups
- 1100 Continue discussion, writing groups
- 1200 Plenary discussion - Status of budgets
- 1300 LUNCH
- 1400 Plenary discussion - Regional and latitudinal comparisons
- 1530 Adjourn

APPENDIX VIII Terms of Reference for Workshop

TERMS OF REFERENCE LOICZ WORKSHOP ON AUSTRALASIAN ESTUARINE SYSTEMS CSIRO Land & Water, Canberra, Australia 12-14 October 1998

Primary Goals:

To work with researchers dealing with Australasian estuarine systems, in order to extract budgetary information from as many systems as feasible from existing data. The Australasian systems (including Australia, Papua New Guinea and New Zealand) span a climatic regime ranging from cool (arid and wet) temperate to both wet and dry tropics; they vary from relatively little to high degree of perturbation from human activities; and many Australasian estuarine systems are very intensively studied. These systems thus provide potential proxies for many areas with relatively little information. The potential latitudinal gradient for these systems is almost 40 degrees. Information to budget many of these systems is available, and there is an active scientific community of researchers working on these lagoons. This workshop will complement an earlier, very successful workshop held in Ensenada, Mexico, in June 1997, a second Mexican workshop in January 1999 (Merida, Mexico), and a South American workshop to be held in November 1999 (Bahia Blanca, Argentina) by the analysis of data from another well-studied region which overlaps and extends beyond many of the climatic, hydrological and latitudinal characteristics of Mexico and Central America.

Anticipated Products:

1. Develop budgets for as many systems as feasible during the workshop.
2. Examine other additional data, brought by the researchers or provided in advance, to scope out how many additional systems can be budgeted over an additional few (~ 2) months.
3. Contribution of these additional sites to two or three papers to be published in the refereed scientific literature: (a) In combination with expected output from the Mexican studies, a paper comparing the biogeochemical functioning of estuaries in arid regions. (b) In combination with expected output from the Mexican and South American workshops and available data from the U.S. and perhaps Canada, a paper on latitudinal gradients in estuarine biogeochemical functioning. (c) A regional paper on comparison of estuarine biogeochemical function over the hydrological and climatic gradients of Australasia.

Participation:

The number of participants will be limited to less than 20 persons, to allow the active involvement of all participants. Nominees include:

- Technical secretariat support (Chris Crossland);
- LOICZ SSC Members (Steve Smith);
- Graham Harris (CSIRO) and Bradley Opdyke (ANU) as local organisers;

- Researchers from Australia and New Zealand research institutes.

Workplan:

Participants will be expected to come prepared to participate in discussions on coastal budgets. Preparation should include reading the LOICZ Biogeochemical Modelling Guidelines (Gordon *et al.*, 1996), the Mexican Lagoons Workshop Report (Smith *et al.*, 1997), examination of the tutorials presented on the LOICZ Modelling web page (<http://data.ecology.su.se/MNODE/>) and arriving with spreadsheets containing available budgeting information from “their sites.”

Each participant should arrive with a draft of at least one water/salt/nutrient budget set, generally following the LOICZ procedures. It would be helpful if participants also brought a draft writeup (1-3 text pages, + site map), in electronic form plus "budget boxes" (hand-drawn for the boxes is okay; these will be drafted according to a common format). Examples can be found in the "Mexican Lagoons" workshop report. For the sake of consistency, please express rates as annual and in molar (rather than mass) units.

Background Documents (for reference, to meet LOICZ initiatives):

1. Gordon, D.C., Boudreau P.R., Mann K.H., Ong J.-E., Silvert W., Smith S.V., Wattayakorn G., Wulff F., and Yanagi T. 1996. LOICZ Biogeochemical Modelling Guidelines. LOICZ Reports and Studies 5, 96 pp.
2. Smith S. V., Ibarra-Obando S., Boudreau P.R., and Camacho-Ibar V.F. 1997. Comparison of Carbon, Nitrogen and Phosphorus Fluxes in Mexican Coastal Lagoons. LOICZ Reports and Studies 10, 84 pp.
3. LOICZ Modelling web page, for everyone with www access: (<http://data.ecology.su.se/MNODE/>)

APPENDIX IX**Glossary of Abbreviations**

NH ₄	Ammonium
NO ₃	Nitrate
DIN	Dissolved inorganic nitrogen
DON	Dissolved organic nitrogen
DIP	Dissolved inorganic phosphorus
DOP	Dissolved organic phosphorus
PTN	Particulate total nitrogen
PTP	Particulate total phosphorus
ON	Organic nitrogen
OP	Organic phosphorus
TN	Total nitrogen
TP	Total phosphorus
DOC	Dissolved organic carbon
DIC	Dissolved inorganic carbon
POC	Particulate organic carbon
OC	Organic carbon
SiO ₄	Silicate
nfix	Nitrogen fixation
ndenit	Denitrification
p	Primary production
r	Respiration
TDN	Total dissolved nitrogen
TDP	Total dissolved phosphorus
CTD	Conductivity Temperature Depth